

Residential AIR TO WATER

- W-002 AIR TO WATER Overview
- W-004 Things We can Contribute to
- W-006 Energy Efficiency Standards
- W-008 AIR TO WATER Series Overview
- W-010 AIR TO WATER Lineup
- W-012 Monobloc Type
 - Comfort series
- W-022 Split Type
 - Comfort series
 - High Power series
 - Super High Power series
- W-038 Indoor Unit
 - Type-A, Type-B
- W-042 Optional Parts & Control Overview
- W-044 Optional Parts List for Type-A
- W-050 Control Overview
- W-052 Optional Parts Overview
- W-054 Optional Parts List for Type-B



AIR TO WATER
Residential

AIR TO WATER Overview

Solutions That Meet a Variety of Needs

Water heated by Air to Water, which uses clean energy, can provide a steady supply of comfortable water throughout the home for heating and hot water applications.



Air to water Heat Pump

Outdoor unit

The unit is used to extract heat from the environment, making use of renewable energy resources from the sun and the outside air.

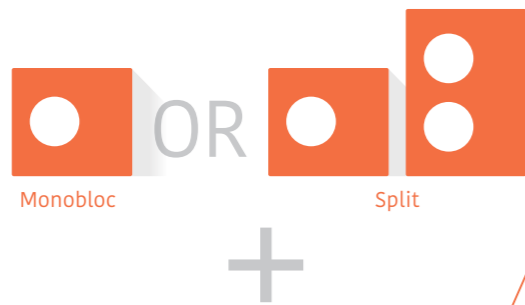

Indoor unit control box*

If you want to update your system by reusing your existing pump and buffer tank, etc., you can do so by installing only the control box.

OR



Indoor unit Wall-mounted

Stands for preparation of heating water for under floor heating and radiators. It can optionally operate with domestic hot water tank.

OR



Indoor unit Domestic Hot Water integrated

Can be used with a variety of heating systems, including under floor heating and radiators. Space saving heating and DHW supply in a single indoor unit.

*The control box can only be selected for Monobloc outdoor unit.

Ecological Consideration in Your Home

Heat pump system framework

Heat is absorbed from the atmosphere by expanding the refrigerant. Higher-temperature heat is generated by compressing the refrigerant, and the indoor unit transfers that heat to the water.

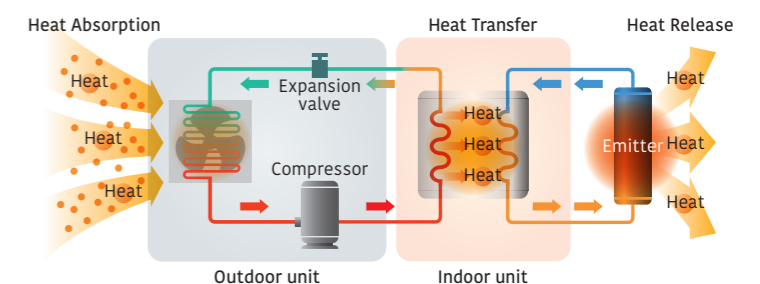

*Split products are listed as examples.

Things We can Contribute to



Our Goal

Decarbonisation

European Commission is committed to decarbonisation and has a national target of “Net Zero” carbon emissions by 2050.

We need to reduce carbon emissions with green technology products and increase carbon absorption by working to extend nature.

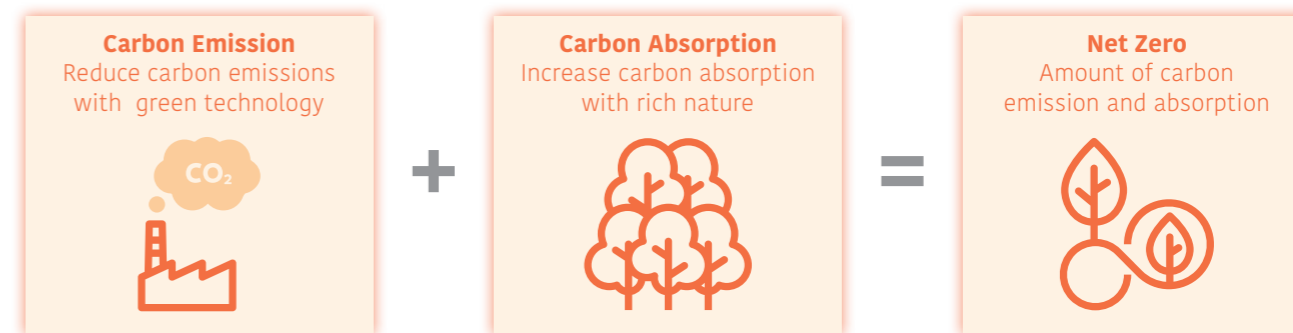

General's ATW system will provide the best solutions that are friendly to the environment and people with products conscious of decarbonisation.

What is a heat pump?

A heat pump extracts heat energy from the atmosphere. It requires only 1 kW of electricity to generate 3 to 5 kW of thermal energy.

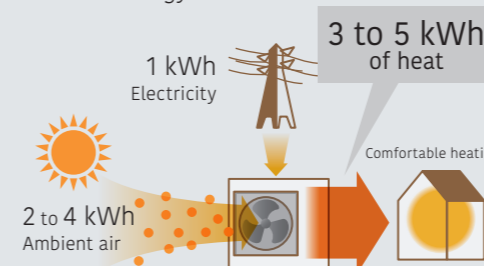

Primary energy usage reduced substantially

Proportion of primary energy converted into heating energy is 100%

Primary Energy Consumption*

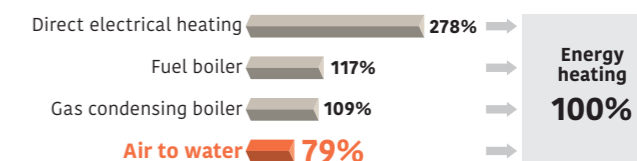

* The amount of electricity loss varies according to the power plant. Typical energy efficiency of a power plant: 36%

The Choice of Air to water

Optimized refrigerant cycle operation

Split Type

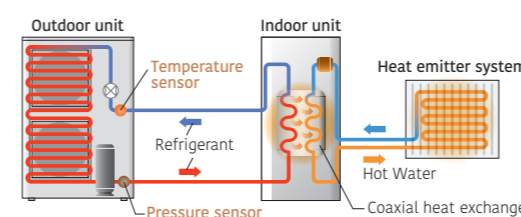

Monobloc Type

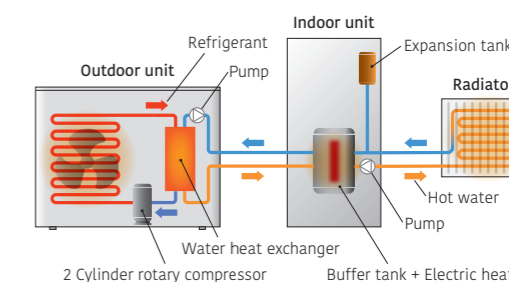

Energy Efficiency Standards Product Labels

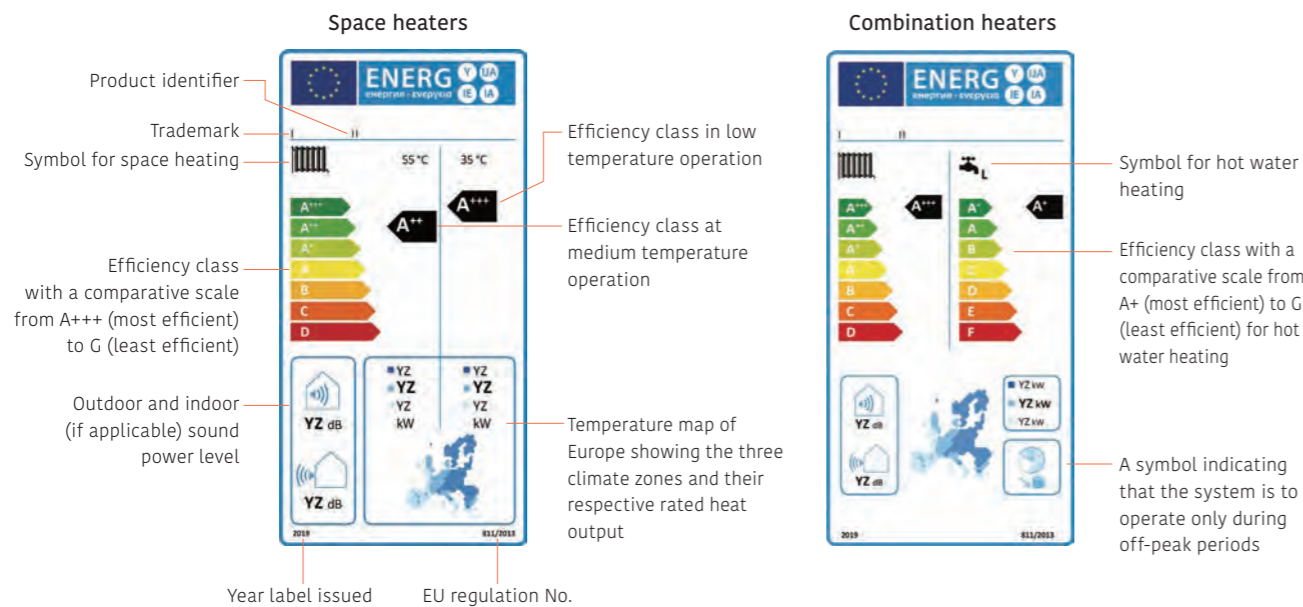

Due to restrictions on the use of fossil fuels in Europe and the F-Gas regulations, the use of environmentally friendly heating equipment is required not only for new buildings but also for renovated properties. Let's consider installing high energy efficiency products that will be essential for future living environments.

Heating Equipment



The Ecodesign Directive Lot 1 Regulation 813/2013

The Ecodesign directive defines a regulatory framework for improving the environmental performance of energy-related products (ErP) through design. Since September 26, 2015, the Ecodesign Directive has applied to space heaters, including heat pumps and fossil fuel fired boilers, combination heaters for space and hot water heating, water heaters, and water storage tanks. All of these products must meet minimum requirements for energy efficiency*1 and maximum sound power level. The minimum energy efficiency class were raised on September 26, 2017, and the maximum sound levels were lowered on September 26, 2018.

*1: Energy efficiency is expressed in terms of seasonal space heating efficiencies (η_s). The value is based upon the Seasonal Coefficient of Performance (SCOP).

The Energy Labelling Directive (EU) No. 811/2013

Energy label is intended to enable consumers to make direct comparisons of energy use and product features. All labels should indicate the product identifier, efficiency class, sound power level, and heat output. Heat generators are rated A+++ to G. There are two different product labels. One for space heaters and one for combination heaters.

Seasonal space heating Energy efficiency class	
Except low temp. HP 55°C	Low temp. HP 35°C
A+++ $\eta_s \geq 150$	$\eta_s \geq 175$
A++ $125 \leq \eta_s < 150$	$150 \leq \eta_s < 175$
A+ $98 \leq \eta_s < 125$	$123 \leq \eta_s < 150$
A $90 \leq \eta_s < 98$	$115 \leq \eta_s < 123$
B $82 \leq \eta_s < 90$	$107 \leq \eta_s < 115$
C $75 \leq \eta_s < 82$	$100 \leq \eta_s < 107$
D $36 \leq \eta_s < 75$	$61 \leq \eta_s < 100$
E $34 \leq \eta_s < 36$	$59 \leq \eta_s < 61$
F $30 \leq \eta_s < 34$	$55 \leq \eta_s < 59$
G $\eta_s < 30$	$\eta_s < 55$

AIR TO WATER Series Overview

ATW Product Simplified Selection Method

Please select a product based on the amount of heat required to maintain a comfortable temperature in the house, just as with air conditioners. For example, the Split comfort series with a low Capacity Range is recommended for newly built houses, as they tend to have high thermal insulation performance.

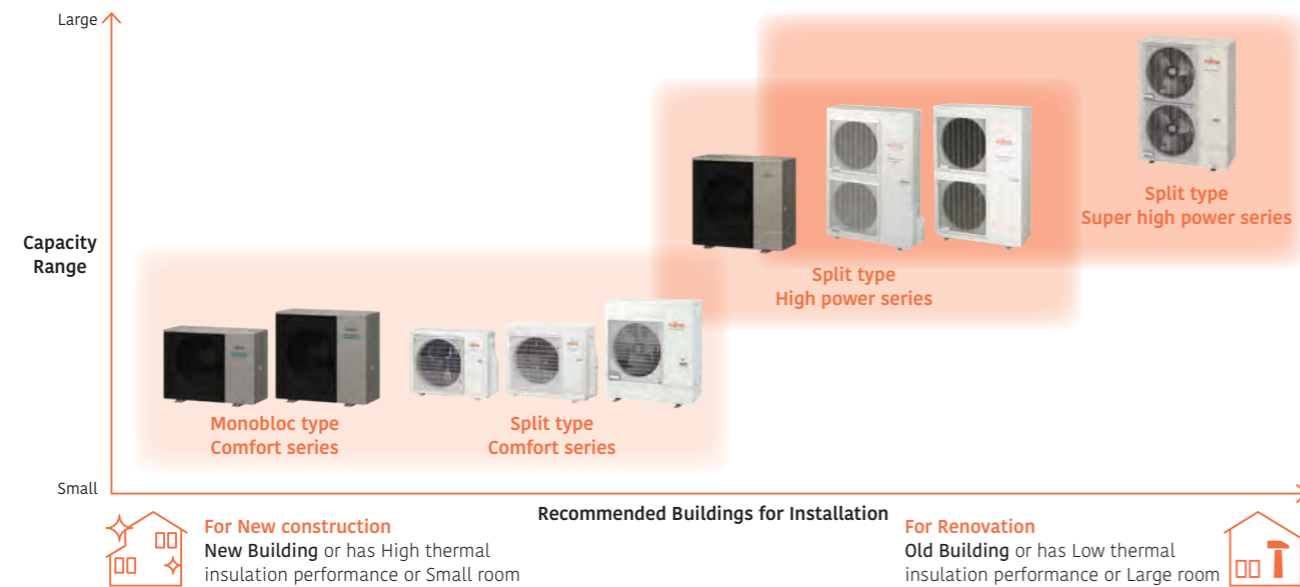

RESIDENTIAL

Monobloc type

Series	System Outline	Refrigerant	Recommended Buildings for Installation
Comfort series 	Indoor unit Control box consists of the hot water circuit controller and the user interface. It is not connected to the water pipe. Outdoor unit <ul style="list-style-type: none"> Supplies 60°C hot water even when the outdoor temperature is -5°C. Supplies 55°C hot water even when the outdoor temperature is -10°C. Can be used with a variety of heating systems, including under floor heating and radiators.* Heating and DHW supply in one system.* Up to Three independent control circuits.* Operating range is -20 to 35°C in heating. Cooling operation is possible 		

* Please refer to page W-042 to W-045 for optional parts information.









RESIDENTIAL

Split type

Series	System Outline	Refrigerant	Recommended Buildings for Installation
Comfort series 	<ul style="list-style-type: none"> Supplies 55°C hot water even when the outdoor temperature is -10°C. Heating and DHW supply in one system.* Equipped with additional electric heater for backup Up to two independent control circuits.* Cooling operation is possible.* Operating range is -20 to 35°C. Can be used with a variety of heating systems, including under floor heating and radiators.* 		
NEW High power series 	<ul style="list-style-type: none"> Supplies 60°C hot water even when the outdoor temperature is -15°C. Can be used with a variety of heating systems, including under floor heating and radiators.* Heating and DHW supply in one system.* Up to Two independent control circuits.* Operating range is -25 to 35°C. 		
High power series 	<ul style="list-style-type: none"> Supplies 60°C hot water even when the outdoor temperature is -20°C. Can be used with a variety of heating systems, including under floor heating and radiators.* Heating and DHW supply in one system.* Up to two independent control circuits.* Cascade connection is possible for up to three systems.* Cooling operation is possible.* Operating range is -25 to 35°C. 		
Super high power series 	<ul style="list-style-type: none"> Supplies 60°C hot water even when the outdoor temperature is -20°C. Can be used with a variety of heating systems, including under floor heating and radiators.* Heating and DHW supply in one system.* Equipped with additional electric heater for backup Up to two independent control circuits.* Cooling operation is possible.* Operating range is -25 to 35°C. 		

* Please refer to page W-050 to W-055 for optional parts information. For options for the R32 High Power Series, refer to W-042 through W-045.

AIR TO WATER Lineup

Type	Series	Refrigerant	Model	Power Source	Capacity							Approval				
					5kw	6kw	8kw	10kw	11kw	14kw	15kw	16kw	17kw	CEN KEYMARK	EHPA	
Monobloc type	Comfort series Control box type	 Heating & Cooling		Single phase, ~230 V, 50 Hz	UTW-SCBEC WPEG050KRF			UTW-SCBEC WPEG080KRF	UTW-SCBEC WPEG100KRF							
	Comfort series Wall-mounted type	 Heating & Cooling		Single phase, ~230 V, 50 Hz	WSEP100KR3 WPEG050KRF			WSEP100KR3 WPEG080KRF	WSEP100KR3 WPEG100KRF							
	Comfort series DHW Integrated type	 Heating & Cooling		Single phase, ~230 V, 50 Hz	WGEP100KR3-19 WPEG050KRF			WGEP100KR3-19 WPEG080KRF	WGEP100KR3-19 WPEG100KRF							

*Cooling is available by using the option



SG ready Label



SG ready is a label issued to heat pumps and their control technologies that meet the requirements set by BWP^{*4}, and technologies that conform to their standards can be integrated into a smart grid. SG ready labeled heat pumps receive signals from the power grid and PV systems with regard to energy and renewable energy sources such as wind, solar, and water. All of General's heat pump series are SG ready compatible.

*4: BWP: Bundesverband Wärmepumpe e. V (Federal German Heat Pump Association)

The CEN Heat Pump KEYMARK



The Heat Pump KEYMARK is a full certificate supporting the quality of heat pumps in the European market. The Heat Pump KEYMARK is a voluntary, independent, European certification mark (ISO Type 5 Certification) for all heat pumps, combination heat pumps, and hot water heaters (as covered by Ecodesign, EU Regulation 813/2013 and 814/2013). General's Air to Water[®] has acquired the KEYMARK certificate^{*6}.

*5: R32 refrigerant comfort model only
*6: Learn more about the validity of the mark at www.heatpumpkeymark.com/about/

AIR TO WATER Lineup

Type	Series	Refrigerant	Model	Power Source	Capacity									Approval			
					5kw	6kw	8kw	10kw	11kw	12kw	14kw	15kw	16kw	17kw	CEN KEYMARK	EHPA	
Split type	Comfort series Wall-mounted type	R32 Heating*		Single phase, ~230 V, 50 Hz	WSYA050ML3 WOYA060KLT	WSYA080ML3 WOYA060KLT	WSYA080ML3 WOYA080KLT	WSYA100ML3 WOYA100KLT									
	Comfort series DHW Integrated type	R32 Heating*		Single phase, ~230 V, 50 Hz	WGYA050ML3 WOYA060KLT	WGYA080ML3 WOYA060KLT	WGYA080ML3 WOYA080KLT	WGYA100ML3 WOYA100KLT									
	High Power series Wall-mounted type	R32 Heating		Single phase, ~230 V, 50 Hz				WSEG140MQ6 WOYG100MQL		WSEG140MQ6 WOYG121MQL	WSEG140MQ6 WOYG140MQL						
		R32 Heating		3-phase, ~400 V, 50 Hz						WSEK140MQ9 WOYK121MQL	WSEK140MQ9 WOYK140MQL						
		R410A Heating*		Single phase, ~230 V, 50 Hz					WSYG140DG6 WOYG112LHT		WSYG140DG6 WOYG140LCTA						
		R410A Heating*		3-phase, ~400 V, 50 Hz					WSYK160DG9 WOYK112LCTA		WSYK160DG9 WOYK140LCTA		WSYK160DG9 WOYK160LCTA				
	High Power series DHW Integrated type	R32 Heating		Single phase, ~230 V, 50 Hz				WGEK140MQ6-19 WOYG100MQL		WGEK140MQ6-19 WOYG121MQL	WGEK140MQ6-19 WOYG140MQL						
		R32 Heating		3-phase, ~400 V, 50 Hz						WGEK140MQ9-19 WOYK121MQL	WGEK140MQ9-19 WOYK140MQL						
		R410A Heating*		Single phase, ~230 V, 50 Hz					WGYG140DG6 WOYG112LHT		WGYG140DG6 WOYG140LCTA						
		R410A Heating*		3-phase, ~400 V, 50 Hz					WGYK160DG9 WOYK112LCTA		WGYK160DG9 WOYK140LCTA		WGYK160DG9 WOYK160LCTA				
	Super High Power series Wall-mounted type	R410A Heating*		Single phase, ~230 V, 50 Hz										WSYG160DJ6 WOYG160LJL			
		R410A Heating*		3-phase, ~400 V, 50 Hz									WSYK170DJ9 WOYK150LJL		WSYK170DJ9 WOYK170LJL		
	Super High Power series DHW Integrated type	R410A Heating*		Single phase, ~230 V, 50 Hz										WGYG160DJ6 WOYG160LJL			
		R410A Heating*		3-phase, ~400 V, 50 Hz									WGYK170DJ9 WOYK150LJL		WGYK170DJ9 WOYK170LJL		

*Cooling is available by using the option

EHPA Quality Label



General's Air to Water² has acquired the EHPA Quality Label³ through testing in accordance with the International Standards EN14511 and EN17025. The EHPA Quality Label³ is a label that shows the end-consumer a quality heat pump unit on the market.

²: 3-phase high power series only
³: Learn more about the validity of the mark at www.ehpa.org/quality/quality-label/

SG ready Label



SG ready is a label issued to heat pumps and their control technologies that meet the requirements set by BWP⁴, and technologies that conform to their standards can be integrated into a smart grid. SG ready labeled heat pumps receive signals from the power grid and PV systems with regard to energy and renewable energy sources such as wind, solar, and water. All of General's heat pump series are SG ready compatible.

⁴: BWP: Bundesverband Wärmepumpe e. V (Federal German Heat Pump Association)

The CEN Heat Pump KEYMARK



The Heat Pump KEYMARK is a full certificate supporting the quality of heat pumps in the European market. The Heat Pump KEYMARK is a voluntary, independent, European certification mark (ISO Type 5 Certification) for all heat pumps, combination heat pumps, and hot water heaters (as covered by Ecodesign, EU Regulation 813/2013 and 814/2013). General's Air to Water⁵ has acquired the KEYMARK certificate⁶.

⁵: R32 refrigerant comfort model only
⁶: Learn more about the validity of the mark at www.heatpumpkeymark.com/about/



Monobloc Type

Comfort series

Fits into Your Life



Monobloc type with fewer pipe works and easy installation. It provides a wide variety of solutions to meet the usage environment.

Aesthetic and Compact Design

By changing from the conventional two-fan system to a large-diameter single-fan system, we have been able to keep the height down. Because it is lower than a house window, you won't have any trouble finding a place to install the outdoor unit.



8 & 10 kW Classes

System configuration example

No refrigerant pipe is required as outdoor unit and indoor unit (or tank) are connected by water pipe

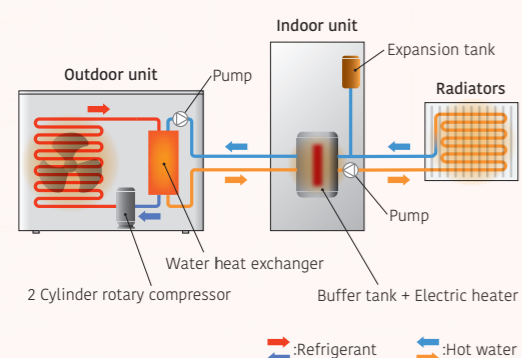

*System configuration when using Wall-mounted indoor unit

High Energy Efficiency

Energy Efficiency Class



*Temperature application: Heating temp. 35°C

Plate heat exchanger with high heat exchange performance improves energy-related product performance, achieving high energy efficiency. All classes achieved top rank A+++* energy efficiency class.

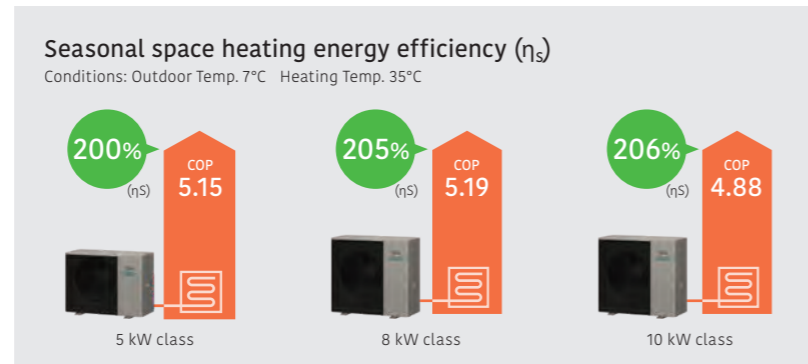

* Value when the control box is connected

5 kW class

Compact & High efficiency Plate heat exchanger

Transmitting the heat of the Refrigerant to the Water.



Inverter Technology

Inverter-equipped models operate at a capacity suited to the heat load. Because they can respond to heat loads in details inverter-equipped models are more economical and comfortable than non-inverter models. Compared to a non-inverter, it reaches the set temperature more quickly, operates at the minimum capacity and responds to slight changes in water temperature. The range of water temperature fluctuation is small, and a comfortable temperature is maintained.

Inverter technology controls temperatures precisely.

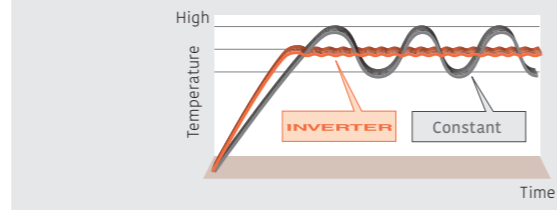

Technology to Achieve High Efficiency

High-precision parts

The precision machining of parts has improved the degree of adhesion between parts. Refrigerant leakage from gaps has been reduced, leading to improved compression efficiency and high-efficiency operation. In addition, the contact surfaces between parts have been smoothed and the amount of wear has been reduced, resulting in stable performance over a long period of time.

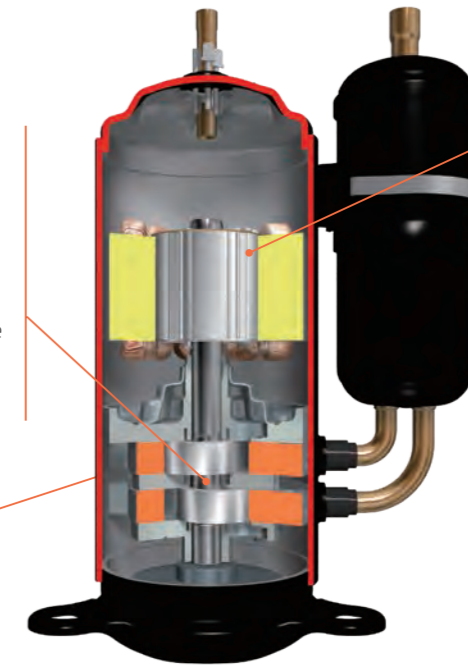

2 Cylinder rotary compressor

High-magnetic flux motor

Copper and iron losses are thoroughly suppressed to realize high magnetic flux of the motor. The high magnetic flux produces stronger torque than ever before. Thanks to this, operation with less current is possible, bringing out high-efficiency operation.



Smooth gas flow

The arrangement of parts that do not obstruct refrigerant flow in the compressor leads to highly efficient operation. Broad interpretation of the optimization of refrigerant flow paths has resulted in about 13 patents.

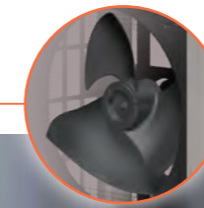

Larger fan

Low Noise Operation

In the outdoor unit, a larger fan and a sound-insulating structure in the compressor part reduce the maximum operating noise. The Monobloc outdoor unit can operate silently at 52 dB(A)* with high energy efficiency. *050 models

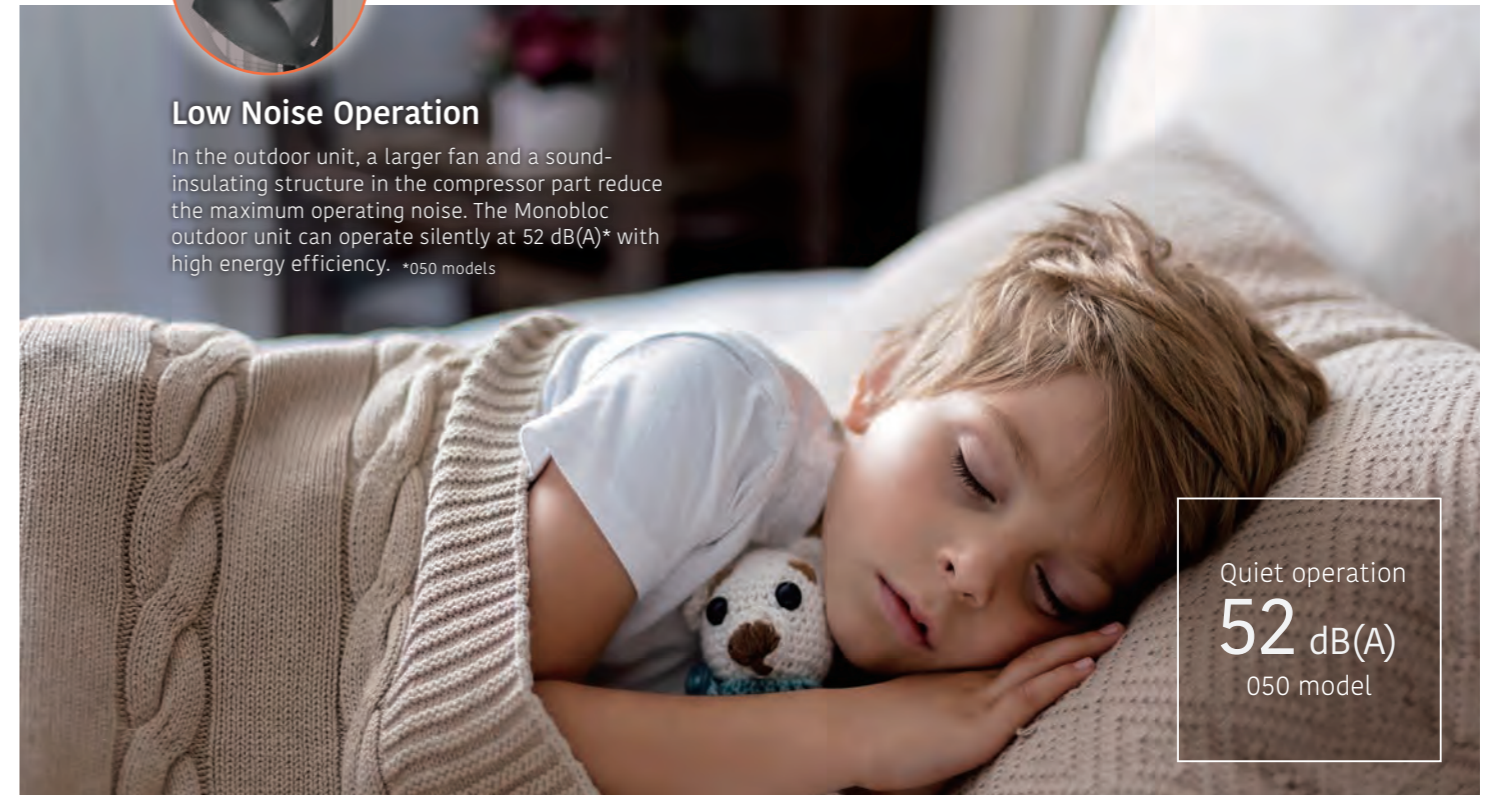

Quiet operation
52 dB(A)
050 model

Durability and Reliability

We take care to ensure that our products can be used by our customers for a long time. We have taken measures to reduce damage to our products even in the event of problems with the installation environment or during operation.



8 & 10 kW classes

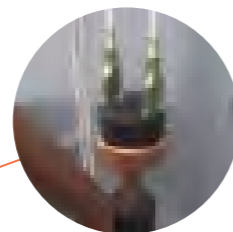

Pressure Switch

The pressure switch equipped on the refrigerant cycle protects the system from malfunction that may be caused by abnormal refrigerant pressure.



Silicon Coating of PCBs

The silicon coating protects the PCBs and their components from damage caused by small animals living in the electrical box and salt.

Optimized shaft design

- The stress on specific parts is reduced, reducing the risk of wear and damage
- Vibration during rotation is reduced, reducing wear and fatigue damage, and ultimately improving durability

DLC coating vane

- It has a very high hardness and low wear coefficient, and shows excellent resistance to wear
- It is chemically stable and has excellent resistance to various working fluids and environmental conditions, so it protects the vanes from corrosion and chemical degradation, contributing to a longer lifespan

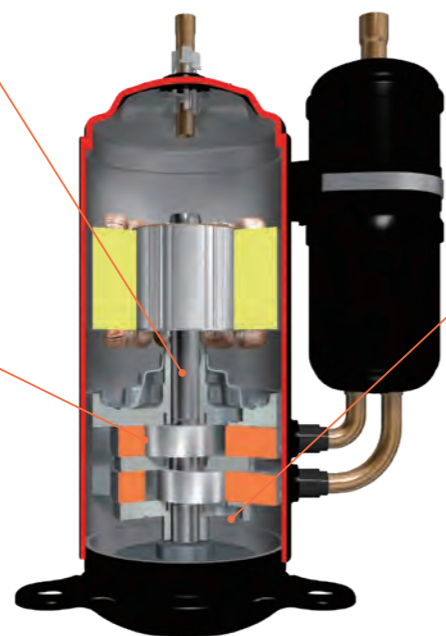

2 Cylinder rotary compressor

Technology to Increase Durability

Optimal lubricant

- Prevents friction and heating of parts, improving durability
- Contains rust-proofing and antioxidant agents, protecting metal parts from corrosion and preventing breakdowns and performance degradation
- Reduces impact between parts, suppresses vibration, and prevents excessive stress on parts, improving durability



*The values in the pictures are examples.

Service Monitor Tool

UTY-ASSXZ1



Bluetooth Communication

AIRSTAGE Service Monitor Tool can diagnose using a smart device and reduce the working time compared with diagnosis by PC. No need to connect a PC making diagnosis easier even in narrow spaces.

Application with simple design

Application for smart devices has been released. The stylish design makes the application easy to use for everyone.



AIRSTAGE Service Monitor Tool

Refrigerant cycle diagram display

The operating status can be displayed with a simple, clear diagram*2 on the smart device. It reduces the time for diagnosis and makes diagnosis easier. It can complement abundant experience and advanced knowledge of refrigerant cycle. This shortens the training time for service personnel.

*2: List and graph displays are also available

Compact and Lightweight Design

This model is easy to carry by compact and lightweight design. The service personnel can visit the maintenance site with small luggage.



Function List

		UTY-ASSXZ1	
Product specification	Installation	Outdoor unit PCB	
	Communication	Bluetooth	
Function	Product distinction	●	
	Signal-type distinction	List	●
		Graph	●
	Operating status display	Refrigerant cycle diagram	●
		Operating history records	●
Adapter firmware update	●		
Adapter status monitoring	●		
Input and output of history data	●		

Specifications

		UTY-ASSXZ1
Dimensions (H x W x D) (mm)		20 x 35 x 60 (adapter)
Communication cable (cm)		60
Weight (g)		25 (adapter)
Communication method		Bluetooth 5.3
Max. communication distance (m)		10*3
Compatible device		Android8.0, iOS17 or later

*3: Depends on the environment

Serviceability and Maintainability

Easy Pipe Work

No refrigerant pipe work is required as the outdoor unit is an integrated unit. The hot water unit comes standard with the outdoor unit. Installation requires only hydraulic connection work, making installation easy.



Easy Installation

Wire connections can be made simply by removing the side panel, so installation work can be easily carried out from a single direction. The compact, lightweight panel is easy to remove.

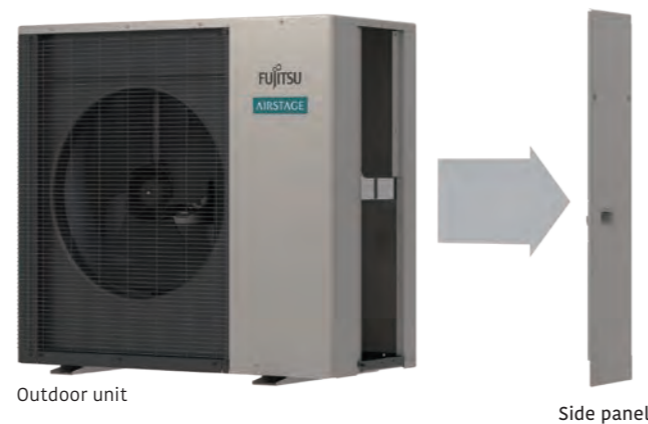

Improved Workability

- The indoor unit is equipped with a buffer tank, DHW connection 3-way valve*, as well as an expansion tank and backup heater
- This improves system reliability and ease of installation

*Wall-mounted only

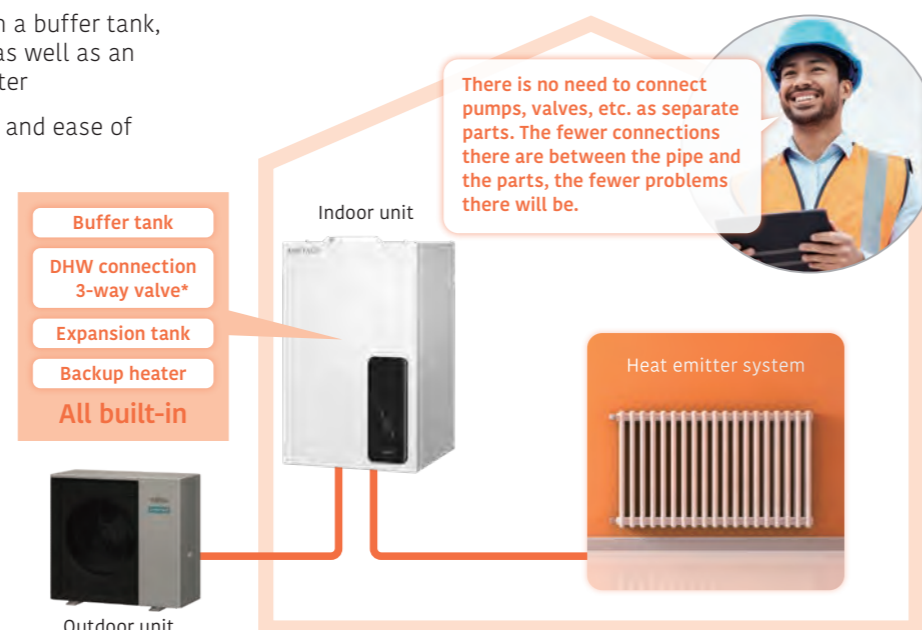

Useful Features

Features	Explanation
Quick recovery from defrosting	Maintains room temperature by boost start operation during defrosting
Auto changeover	When auto mode is selected, the system automatically switches between cooling and heating modes depending on the outside temperature.
2-zone independent control	2-zone independent control
Backup heater operation	Backup heater maintains a comfortable room temperature even when the outside temperature is low. It is intelligently controlled as a safety backup for very cold days and nights, and only operates when really needed.
Peak cut function	Sets the peak current value to reduce power consumption. Mode 1 -> 100% Mode 2 -> 75% Mode 3 -> 50% Mode 4 -> Almost 0%
Anti-Freezing function	When the outside temperature drops below a specified level, the compressor will self-activate and water will also be automatically circulated to prevent freezing.
Anti-Legionella function	Prevents the growth of Legionella bacteria in the DHW tank to supply safe and clean hot water at all times.
Emergency operation	If an outdoor unit fails to operate, a built-in backup heater or an external boiler is activated to supply an uninterrupted supply of hot water to the house.



Monobloc type
Comfort series (Control box type)

Indoor unit:
UTW-SCBEC

Outdoor unit:
WPEG050KRF / WPEG080KRF
WPEG100KRF



Specifications

Model Name	Indoor unit		Control box			
	Outdoor unit		UTW-SCBEC	UTW-SCBEC	UTW-SCBEC	UTW-SCBEC
Capacity Range			WPEG050KRF	WPEG080KRF	WPEG100KRF	WPEG100KRF
			5	8	10	10
7°C/35°C floor heating*1	Heating capacity (Max.)	kW	5.00 (8.31)	8.00 (13.28)	10.00 (15.20)	10.00 (15.20)
	Input power (Max.)		0.97 (1.97)	1.54 (2.96)	2.05 (3.53)	2.05 (3.53)
	COP (Max.)		5.15 (4.22)	5.19 (4.48)	4.88 (4.30)	4.88 (4.30)
7°C/55°C radiator*1	Heating capacity (Max.)	kW	5.00 (7.21)	8.00 (10.60)	10.00 (11.56)	10.00 (11.56)
	Input power (Max.)		1.64 (2.44)	2.62 (3.51)	3.36 (3.94)	3.36 (3.94)
	COP (Max.)		3.04 (2.95)	3.05 (3.02)	2.98 (2.93)	2.98 (2.93)
-7°C/55°C radiator*1	Heating capacity (Max.)	kW	4.80 (5.36)	7.50 (8.15)	8.50 (9.00)	8.50 (9.00)
	Input power (Max.)		2.25 (2.57)	3.50 (3.94)	3.97 (3.94)	3.97 (3.94)
	COP (Max.)		2.13 (2.09)	2.14 (2.07)	2.14 (2.93)	2.14 (2.93)
35°C/18°C cooling mode*1	Cooling capacity (Max.)	kW	5.45 (6.55)	7.79 (10.87)	9.40 (10.87)	9.40 (10.87)
	Input power (Max.)		1.25 (1.82)	1.69 (3.22)	2.40 (3.22)	2.40 (3.22)
	EER (Max.)		4.35 (3.60)	4.62 (3.37)	3.91 (3.37)	3.91 (3.37)
Space heating characteristics*2						
Temperature application	°C		55	35	55	35
Energy efficiency class			A++	A+++	A++	A+++
Rated heat output (P _{rated})	kW		6	6	9	10
Seasonal space heating energy efficiency (η _s)	%		143	200	144	206
Annual energy consumption	kWh		3,110	2,364	4,880	4,018
Sound power level*3	dB(A)		52	52	56	57
Indoor unit specifications						
Power source	Single phase, 230 V, 50 Hz					
Dimensions H × W × D	mm		483 × 370 × 222			
Weight (Net)	kg		10			
Outdoor unit specifications						
Power source	Single phase, 230 V, 50 Hz					
Current	Max. A		14.6		19.1	
Water flow temperature range	Max. °C		60		60	
Dimensions H × W × D	mm		798 × 1,080 × 480		1,008 × 1,080 × 480	
Weight (Net)	kg		85		109	
Refrigerant	Type (Global Warming Potential)		R32 (675)		R32 (675)	
	Charge		kg		1.47	
Connection pipe	Diameter		mm		Ø25.4	
Operating range	Heating		°C		-20 to 35	

*1: Heating capacity, input power, and COP are measured using the EN14511 standard. Actual usage environments, such as the operating modes of the heating equipment, room temperature, and controller settings, may cause differences in values between those listed in the catalog and the actual performance characteristics.
*2: Information about ErP can be downloaded from our website at www.generalw.com/global/support/downloads/search/
*3: The sound power level values are based on EN12102 standard measurements under EN14825 standard conditions.

Dimensions

(Unit: mm)

Control box:
UTW-SCBEC

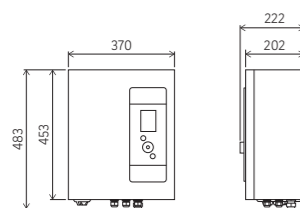

Wall Mounted:
WSEP100KR3

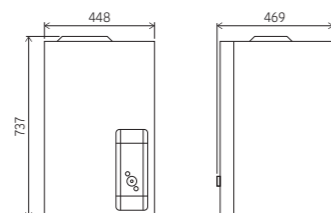

DHW Integrated:
WGEP100KR3-19

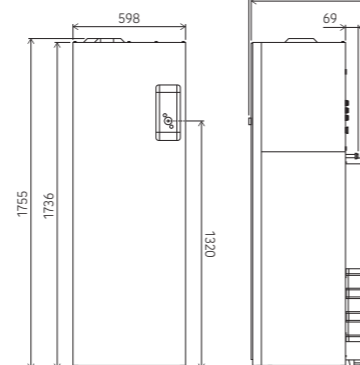

Outdoor unit:
WPEG050KRF

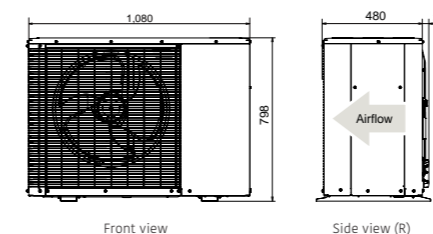

WPEG080KRF/WPEG100KRF

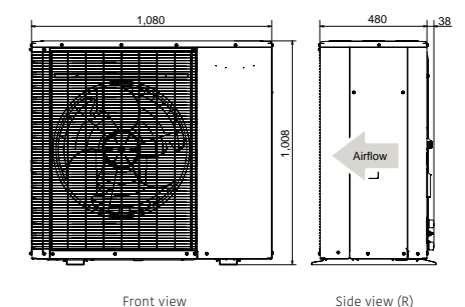

Monobloc type
Comfort series (Wall-mounted type / DHW Integrated type)

Indoor unit:
WSEP100KR3
WGEP100KR3-19

Outdoor unit:
WPEG050KRF / WPEG080KRF
WPEG100KRF



Specifications

Model Name	Indoor unit		Wall Mounted			DHW Integrated		
	Outdoor unit		WSEP100KR3	WSEP100KR3	WSEP100KR3	WGEP100KR3-19	WGEP100KR3-19	WGEP100KR3-19
Capacity Range			WPEG050KRF	WPEG080KRF	WPEG100KRF	WPEG050KRF	WPEG080KRF	WPEG100KRF
			5	8	10	5	8	10
7°C/35°C floor heating*1	Heating capacity (Max.)	kW	5.00 (8.10)	8.00 (13.07)	10.00 (14.99)	5.00 (8.10)	8.00 (13.07)	10.00 (14.99)
	Input power (Max.)		1.00 (2.00)	1.57 (3.08)	2.13 (3.64)	1.00 (2.00)	1.57 (3.08)	2.13 (3.64)
	COP (Max.)		4.99 (4.05)	5.08 (4.24)	4.70 (4.11)	4.99 (4.05)	5.08 (4.24)	4.70 (4.11)
7°C/55°C radiator*1	Heating capacity (Max.)	kW	5.00 (6.86)	8.00 (10.24)	10.00 (11.20)	5.00 (6.86)	8.00 (10.24)	10.00 (11.20)
	Input power (Max.)		1.72 (2.47)	2.62 (3.55)	3.40 (3.99)	1.72 (2.47)	2.62 (3.55)	3.40 (3.99)
	COP (Max.)		2.91 (2.77)	3.05 (2.89)	2.94 (2.81)	2.91 (2.77)	3.05 (2.89)	2.94 (2.81)
-7°C/55°C radiator*1	Heating capacity (Max.)	kW	4.80 (4.90)	7.50 (7.69)	8.50 (8.54)	4.80 (4.90)	7.50 (7.69)	8.50 (8.54)
	Input power (Max.)		2.51 (2.62)	3.62 (3.99)	4.11 (4.35)	2.51 (2.62)	3.62 (3.99)	4.11 (4.35)
	COP (Max.)		1.91 (1.87)	2.07 (1.93)	2.07 (1.96)	1.91 (1.87)	2.07 (1.93)	2.07 (1.96)
35°C/18°C cooling mode*1	Cooling capacity (Max.)	kW	5.35 (6.42)	7.69 (10.75)	9.30 (10.75)	5.35 (6.42)	7.69 (10.75)	9.30 (10.75)
	Input power (Max.)		1.26 (1.85)	1.72 (3.32)	2.47 (3.32)	1.26 (1.85)	1.72 (3.32)	2.47 (3.32)
	EER (Max.)		4.23 (3.48)	4.47 (3.24)	3.77 (3.24)	4.23 (3.48)	4.47 (3.24)	3.77 (3.24)
Space heating characteristics*2								
Temperature application	°C		55	35	55	35	55	35
Energy efficiency class			A++	A+++	A++	A+++	A++	A+++
Rated heat output (P _{rated})	kW		6	6	9	9	10	10
Seasonal space heating energy efficiency (η _s)	%		133	189	139	195	141	195
Annual energy consumption	kWh		3,355	2,503	5,078	3,764	5,685	4,269
Sound power level*3	dB(A)		52	52	56	56	57	57
Indoor unit specifications								
Power source	Single phase, 230 V, 50 Hz							
Dimensions H × W × D	mm		737 × 448 × 469			1755 × 598 × 623		
Weight (Net)	kg		34.0			130.0		
Water circulation	Min./Max. L/min		8.5			14.5		
DHW tank volume	L		-			190		
Buffer tank capacity	L		16			16		
Expansion vessel capacity	L		12			12		
Water flow temperature range	Max. °C		60			60		
Water pipe connection diameter	Flow/Return mm		Ø19.05/Ø19.05			Ø19.05/Ø19.05		
Electrical heater capacity	Heating kW		3.0			3.0		
	DHW kW		-			1.2		
Declared load profile			-			L		
Efficiency ηDHW	%		-			124		
Heating up time			-			1h45min		
COP(EN16147)			-			3.10		
Outdoor unit specifications								
Power source	Single phase, 230 V, 50 Hz							
Current	Max. A		14.6		19.1		20.6	
Water flow temperature range	Max. °C		60		60		60	
Dimensions H × W × D	mm		798 × 1,080 × 480		1,008 × 1,080 × 480		1,008 × 1,080 × 480	
Weight (Net)	kg		85		109		109	
Refrigerant	Type (Global Warming Potential)		R32 (675)		R32 (675)		R32 (675)	
	Charge		kg		1.47		1.47	
Connection pipe	Diameter		mm		Ø25.4		Ø25.4	
Operating range	Heating		°C		-20 to 35		-20 to 35	

*1: Heating capacity, input power, and COP are measured using the EN14511 standard. Actual usage environments, such as the operating modes of the heating equipment, room temperature, and controller settings, may cause differences in values between those listed in the catalog and the actual performance characteristics.
*2: Information about ErP can be downloaded from our website at www.generalw.com/global/support/downloads/search/
*3: The sound power level values are based on EN12102 standard measurements under EN14825 standard conditions.



Split Type
Comfort series
High Power series



Split Type
High Power series
Super High Power series

This is a split type that exchanges heat from Air to Water inside the indoor unit.

A wide range of products to suit regional characteristics, family structures, and usage patterns. We provide a variety of products to meet the needs of customers from the heating-centered high power series to the reasonably priced compact series.

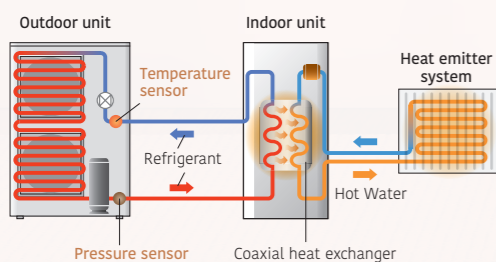

*Indoor unit : Wall-mounted

High Water Flow Temperature

The temperature of water flow can be maintained at 60°C without using a backup heater, even when the outdoor temperature drops to -20°C*.

* The Super High Power Series and The R410A High Power Series only. The R32 High Power Series is rated for -15°C. The Comfort Series is rated for -10°C.



NEW High Power series

High Power series & Super High Power series



NEW High Power series

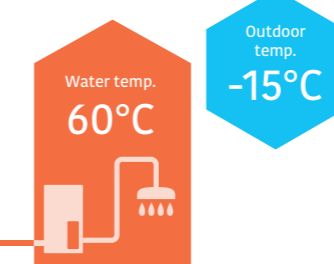

Comfort series



* If you want to raise the temperature of the water supply to above the maximum temperature, use a backup heater

High COP

Heat pumps of ATW Systems work more efficiently and consume less energy than conventional heating systems.

Seasonal space heating energy efficiency (η_s)

*Conditions: Outdoor Temp. 7°C, Heating Temp. 35°C



Energy efficiency class

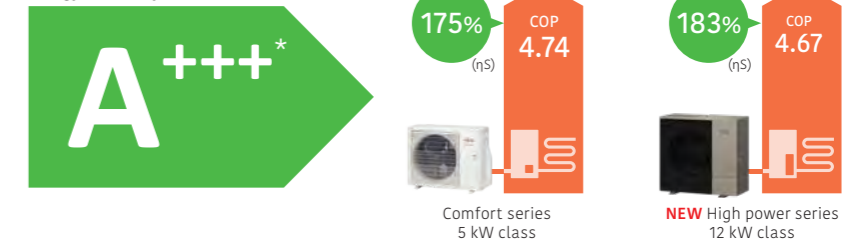

Energy efficiency class



High Energy Efficiency

Outdoor Unit Technology to Achieve high Efficiency

High-magnetic flux motor

Copper and iron losses are thoroughly suppressed to realize high magnetic flux of the motor. The high magnetic flux produces stronger torque than ever before. Thanks to this, operation with less current is possible, bringing out high-efficiency operation.

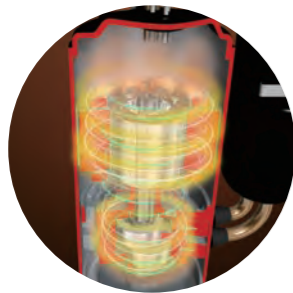

Smooth gas flow

The arrangement of parts that do not obstruct refrigerant flow in the compressor leads to highly efficient operation. Broad interpretation of the optimization of refrigerant flow paths has resulted in about 13 patents.

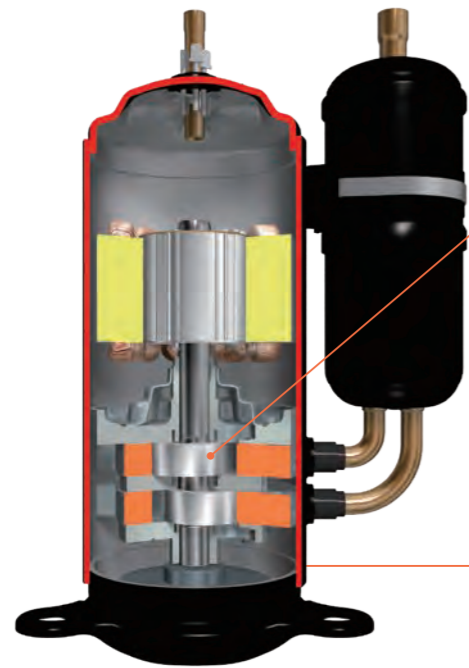

2 Cylinder rotary compressor

High-precision parts

The precision machining of parts has improved the degree of adhesion between parts. Refrigerant leakage from gaps has been reduced, leading to improved compression efficiency and high-efficiency operation. In addition, the contact surfaces between parts have been smoothed and the amount of wear has been reduced, resulting in stable performance over a long period of time.

NEW High power series outdoor unit



Larger fan

Low Noise Operation

In the outdoor unit, a larger fan and a sound-insulating structure in the compressor part reduce the maximum operating noise. The Split type High power Series outdoor unit can operate silently at 56 dB(A)* with high energy efficiency. *10/12 kW models



Comfort series outdoor unit

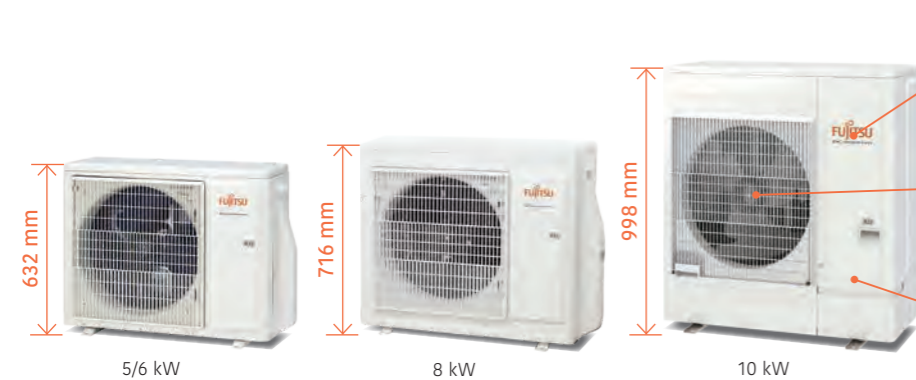

DC Inverter
DC inverter provides smooth water temperature control.

DC Fan Motor
High-performance, high-efficiency small DC fan motor mounted

DC Twin-Rotary Compressor
High-efficiency DC twin-rotary compressor

Twin-Rotary Compressor with Linear Control Injection Port

The compressor achieves a high condensing temperature without overheating the discharge gas temperature due to the Linear control injection process used during compression. This makes the condensing temperature higher than in a normal circuit. Higher water temperatures can be achieved by controlling the injection volume according to usage conditions.

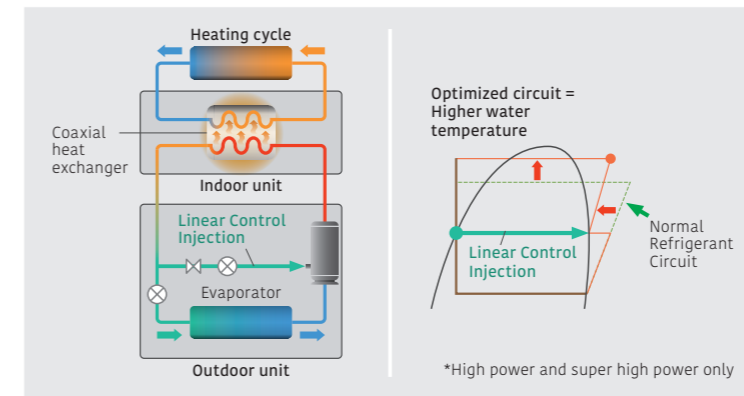

Super High power series outdoor unit



High power series outdoor unit

Indoor Unit Technology to Achieve high Efficiency



Class A Pump

Energy-saving pump with the ability to adjust the flow rate and pressure to a constant level

High-durability coaxial heat exchanger

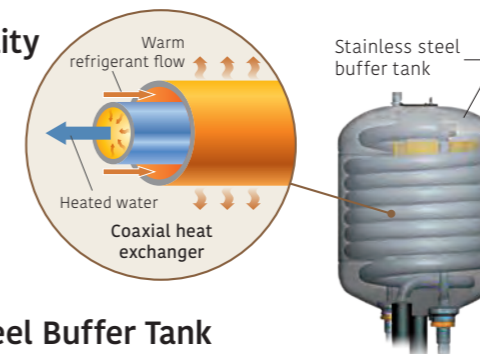

Stainless Steel Buffer Tank

Energy-saving performance has also been improved. The buffer tank has anti-corrosion protection thanks to stainless steel material.



Wall-mounted



DHW Integrated

Durability and Reliability



We take care to ensure that our products can be used by our customers for a long time. We have taken measures to reduce damage to our products even in the event of problems with the installation environment or during operation.

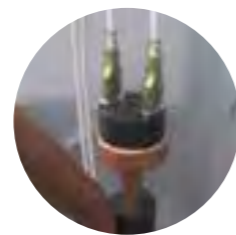

Pressure Switch
The pressure switch equipped on the refrigerant cycle protects the system from malfunction that may be caused by abnormal refrigerant pressure.

Silicon Coating of PCBs

The silicon coating protects the PCBs and their components from damage caused by small animals living in the electrical box and salt.



Technology to Increase Durability

Optimal bearings

Reduced stress on specific parts of the body reduces the risk of wear and tear. Reduced vibration during rotation reduces wear and fatigue damage, resulting in increased durability.

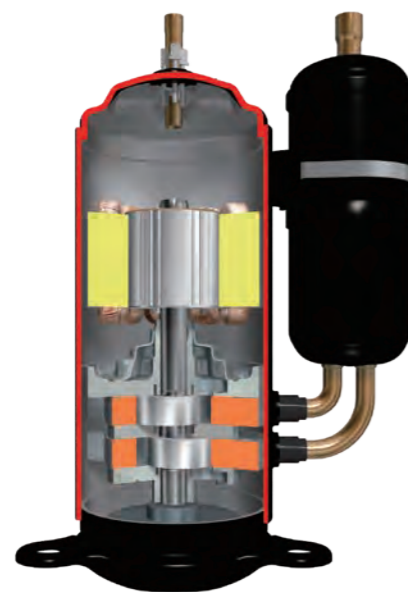

2 Cylinder rotary compressor
NEW High power series

Coated vane

- Very high hardness and low coefficient of wear, providing excellent resistance to abrasion. Scientifically stable and highly resistant to a wide range of working fluids and environmental conditions, it protects vanes from corrosion and chemical degradation, contributing to longer service life.

Optimal lubricating oil

- Improves durability by preventing friction and heating of parts
- Contains rust inhibitors and antioxidants to protect metal parts from corrosion, which can cause failure and loss of performance.
- Reduces shock and vibration between parts, preventing overstressing of parts and increasing durability

Serviceability and Maintainability

Improved Workability

- The indoor unit is equipped with a buffer tank, DHW connection 3-way valve*, as well as an expansion tank and backup heater
- This improves system reliability and ease of installation

*Wall-mounted only

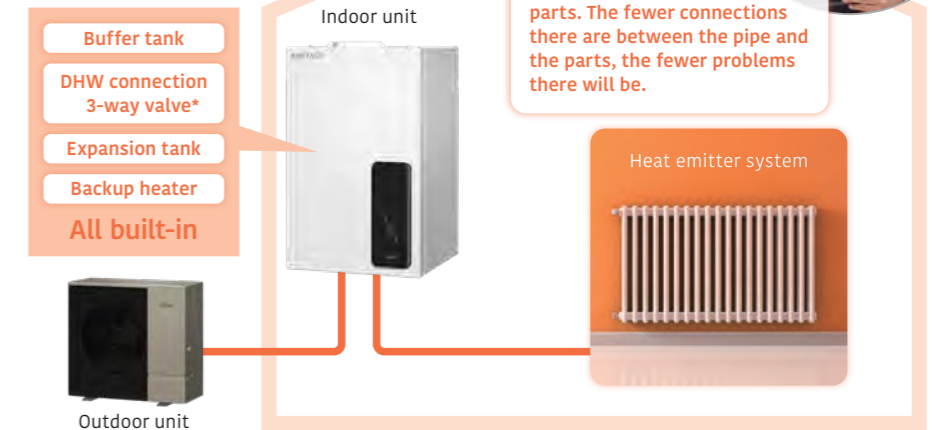

Useful Features

Features	Explanation
Quick recovery from defrosting	Maintains room temperature by boost start operation during defrosting
Auto changeover	When cooling mode is selected, the system automatically switches between cooling and heating modes depending on the outside temperature.
2-zone independent control	2-zone independent control
Backup heater operation	Backup heater maintains a comfortable room temperature even when the outside temperature is low. It is intelligently controlled as a safety backup for very cold days and nights, and only operates when really needed.
Peak cut function	Sets the peak current value to reduce power consumption. Mode 1 -> 100% Mode 2 -> 75% Mode 3 -> 50% Mode 4 -> Almost 0%
Anti-Freezing function	When the outside temperature drops below a specified level, the compressor will self-activate and water will also be automatically circulated to prevent freezing.
Anti-Legionella function	Prevents the growth of Legionella bacteria in the DHW tank to supply safe and clean hot water at all times.
Emergency operation	If an outdoor unit fails to operate, a built-in backup heater or an external boiler is activated to supply an uninterrupted supply of hot water to the house.

Smart Control

To meet the diverse needs of customers, we offer a variety of control options, such as individual control and remote control options.

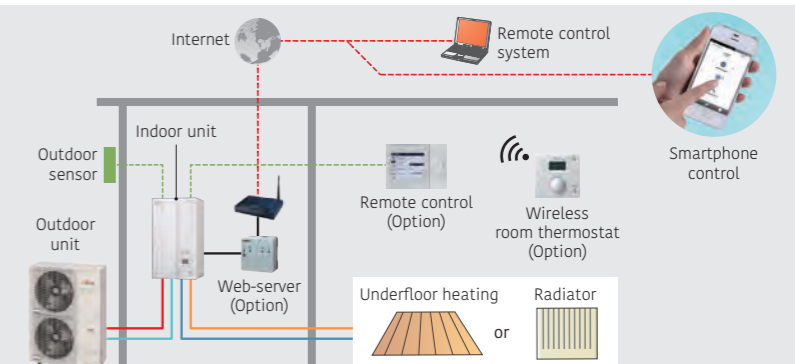

Split type
Comfort series (Wall-mounted type)

Indoor unit:
WSYA050ML3 / WSYA080ML3 / WSYA100ML3
Outdoor unit:
WOYA060KLT / WOYA080KLT / WOYA100KLT



Specifications

Model Name	Indoor unit	Outdoor unit	WSYA050ML3	WSYA080ML3	WSYA080ML3	WSYA100ML3				
Capacity Range			5	6	8	10				
7°C/35°C floor heating*1	Heating capacity (Max.)	kW	4.50 (7.64)	5.50 (8.93)	7.50 (9.64)	9.50 (15.29)				
	Input power (Max.)	kW	0.949 (1.80)	1.18 (2.24)	1.69 (2.46)	2.11 (3.89)				
	COP (Max.)		4.74 (4.24)	4.65 (3.99)	4.43 (3.92)	4.50 (3.93)				
2°C/35°C floor heating*1	Heating capacity	kW	4.50	5.30	6.30	9.30				
	Input power	kW	1.33	1.65	1.96	3.08				
	COP		3.39	3.22	3.21	3.02				
-7°C/35°C floor heating*1	Heating capacity (Max.)	kW	4.40 (4.97)	5.00 (6.13)	5.70 (7.05)	8.90 (10.40)				
	Input power (Max.)	kW	1.59 (1.67)	1.90 (2.12)	2.13 (2.55)	3.36 (3.62)				
	COP (Max.)		2.76 (2.98)	2.63 (2.89)	2.68 (2.76)	2.65 (2.87)				
-7°C/55°C Radiator*1	Heating capacity (Max.)	kW	3.90 (4.24)	4.25 (4.86)	5.30 (5.85)	8.00 (8.00)				
	Input power (Max.)	kW	2.11 (2.25)	2.25 (2.69)	2.79 (3.26)	4.10 (4.10)				
	COP (Max.)		1.85 (1.88)	1.89 (1.81)	1.90 (1.79)	1.95 (1.95)				
Space heating characteristics**										
Temperature application	°C		55	35	55	35	55	35	55	35
Energy efficiency class			A++	A+++	A++	A+++	A++	A+++	A++	A+++
Rated heat output (P _{rated})	kW		5	5	6	6	7	8	9	9
Seasonal space heating energy efficiency (η _s)	%		125	175	125	175	128	177	130	178
Annual energy consumption	kWh		3,035	2,322	3,411	2,594	3,903	2,982	5,083	3,875
Sound power level*3	Indoor unit	dB(A)	40	-	40	-	40	-	40	-
	Outdoor unit	dB(A)	57	-	57	-	60	-	62	-
Indoor unit specifications										
Power source	Single phase, ~230 V, 50 Hz									
Dimensions H × W × D	mm		847 × 450 × 493	847 × 450 × 493	847 × 450 × 493	847 × 450 × 493				
Weight (Net)	kg		47	47	47	47				
Water circulation	Min./Max.	L/min	7.6/22.0	8.5/22.0	10.0/22.0	13.2/30.0				
Buffer tank capacity	L		16	16	16	16				
Expansion vessel capacity	L		8	8	8	8				
Water flow temperature range	Max.	°C	55	55	55	55				
Water pipe connection diameter	Flow/Return	mm	Ø25.4/Ø25.4	Ø25.4/Ø25.4	Ø25.4/Ø25.4	Ø25.4/Ø25.4				
Electrical heater capacity	Heating	kW	3.0	3.0	3.0	3.0				
Outdoor unit specifications										
Power source	Single phase, ~230 V, 50 Hz									
Current	Max.	A	13.0	13.0	18.0	19.0				
Dimensions H × W × D	mm		632 × 799 × 290	632 × 799 × 290	716 × 820 × 315	998 × 940 × 320				
Weight (Net)	kg		39	39	42	62				
Refrigerant	Type (Global Warming Potential)		R32 (675)	R32 (675)	R32 (675)	R32 (675)				
	Charge	kg	0.97	0.97	1.02	1.63				
Additional refrigerant charge		g/m	25	25	25	20				
Connection pipe	Diameter	Liquid	mm	6.35	6.35	6.35	9.52			
		Gas	mm	12.70	12.70	12.70	15.88			
	Length	Min./Max.	m	3/30	3/30	3/30	3/30			
		Length (Pre-charge)	m	15	15	15	20			
Height difference	Max.	m	20	20	20	20				
Operating range	Heating	°C	-20 to 35	-20 to 35	-20 to 35	-20 to 35				

*1: Heating capacity, input power, and COP are measured using the EN14511 standard. Actual usage environments, such as the operating modes of the heating equipment, room temperature, and controller settings, may cause differences in values between those listed in the catalog and the actual performance characteristics.
*2: Information about ErP can be downloaded from our website at www.generalw.com/global/support/downloads/search/
*3: The sound power level values are based on EN12102 standard measurements under EN14825 standard conditions.

Dimensions

(Unit: mm)

Indoor Unit:
WSYA050ML3/WSYA080ML3/WSYA100ML3

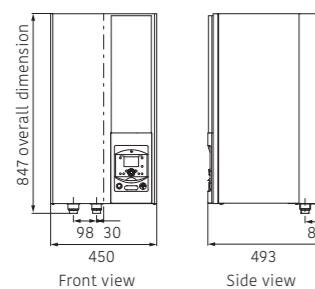

WGYA050ML3/WGYA080ML3/WGYA100ML3

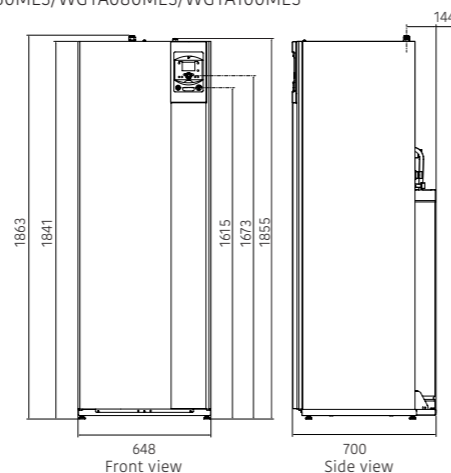

Split type
Comfort series (DHW Integrated type)

Indoor unit:
WGYA050ML3 / WGYA080ML3 / WGYA100ML3
Outdoor unit:
WOYA060KLT / WOYA080KLT / WOYA100KLT



Specifications

Model Name	Indoor unit	Outdoor unit	WGYA050ML3	WGYA080ML3	WGYA080ML3	WGYA100ML3				
Capacity range			5	6	8	10				
7°C/35°C floor heating*1	Heating capacity (Max.)	kW	4.50 (7.64)	5.50 (8.93)	7.50 (9.64)	9.50 (15.29)				
	Input power (Max.)	kW	0.949 (1.80)	1.18 (2.24)	1.69 (2.46)	2.11 (3.89)				
	COP (Max.)		4.74 (4.24)	4.65 (3.99)	4.43 (3.92)	4.50 (3.93)				
2°C/35°C floor heating*1	Heating capacity	kW	4.50	5.30	6.30	9.30				
	Input power	kW	1.33	1.65	1.96	3.08				
	COP		3.39	3.22	3.21	3.02				
-7°C/35°C floor heating*1	Heating capacity (Max.)	kW	4.40 (4.97)	5.00 (6.13)	5.70 (7.05)	8.90 (10.40)				
	Input power (Max.)	kW	1.59 (1.67)	1.90 (2.12)	2.13 (2.55)	3.36 (3.62)				
	COP (Max.)		2.76 (2.98)	2.63 (2.89)	2.68 (2.76)	2.65 (2.87)				
-7°C/55°C Radiator*1	Heating capacity (Max.)	kW	3.90 (4.24)	4.25 (4.86)	5.30 (5.85)	8.00 (8.00)				
	Input power (Max.)	kW	2.11 (2.25)	2.25 (2.69)	2.79 (3.26)	4.10 (4.10)				
	COP (Max.)		1.85 (1.88)	1.89 (1.81)	1.90 (1.79)	1.95 (1.95)				
Space heating characteristics**										
Temperature application	°C		55	35	55	35	55	35		
Energy efficiency class			A++	A+++	A++	A+++	A++	A+++		
Rated heat output (P _{rated})	kW		5	5	6	6	7	8	9	
Seasonal space heating energy efficiency (η _s)	%		125	175	125	175	128	177	130	178
Annual energy consumption	kWh		3,035	2,322	3,411	2,594	3,903	2,982	5,083	3,875
Sound power level*3	Indoor unit	dB(A)	40	-	40	-	40	-	40	-
	Outdoor unit	dB(A)	57	-	57	-	60	-	62	-
Domestic hot water characteristics**										
Load profile	L									
Energy efficiency class			A+	A+	A+	A+				
Energy efficiency (η _{nwh})	%		130	130	130	130				
Annual electricity consumption	kWh		793	793	793	793				
Indoor unit specifications										
Power source	Single phase, ~230 V, 50 Hz									
Dimensions H × W × D	mm		1,863 × 648 × 700	1,863 × 648 × 700	1,863 × 648 × 700	1,863 × 648 × 700				
Weight (Net)	kg		145	145	145	145				
Water circulation	Min./Max.	L/min	7.6/22.0	8.5/22.0	10.0/22.0	13.2/30.0				
DHW tank volume	L		190	190	190	190				
Electrical heater capacity	Heating	kW	3.0	3.0	3.0	3.0				
	DHW	kW	1.5	1.5	1.5	1.5				
Buffer tank capacity	L		16	16	16	16				
Expansion vessel capacity	L		8	8	8	8				
Water flow temperature range	Max.	°C	55	55	55	55				
Water pipe connection diameter	Flow/Return	mm	Ø25.4/Ø25.4	Ø25.4/Ø25.4	Ø25.4/Ø25.4	Ø25.4/Ø25.4				
Hot water pipe connection diameter		mm	Ø19.05	Ø19.05	Ø19.05	Ø19.05				
Outdoor unit specifications										
Power source	Single phase, ~230 V, 50 Hz									
Current	Max.	A	13.0	13.0	18.0	19.0				
Dimensions H × W × D	mm		632 × 799 × 290	632 × 799 × 290	716 × 820 × 315	998 × 940 × 320				
Weight (Net)	kg		39	39	42	62				
Refrigerant	Type (Global Warming Potential)		R32 (675)	R32 (675)	R32 (675)	R32 (675)				
	Charge	kg	0.97	0.97	1.02	1.63				
Additional refrigerant charge		g/m	25	25	25	20				
Connection pipe	Diameter	Liquid	mm	6.35	6.35	6.35	9.52			
		Gas	mm	12.70	12.70	12.70	15.88			
	Length	Min./Max.	m	3/30	3/30	3/30	3/30			
		Length (Pre-charge)	m	15	15	15	20			
Height difference	Max.	m	20	20	20	20				
Operating range	Heating	°C	-20 to 35	-20 to 35	-20 to 35	-20 to 35				

*1: Heating capacity, input power, and COP are measured using the EN14511 standard. Actual usage environments, such as the operating modes of the heating equipment, room temperature, and controller settings, may cause differences in values between those listed in the catalog and the actual performance characteristics.
*2: Information about ErP can be downloaded from our website at www.generalw.com/global/support/downloads/search/
*3: The sound power level values are based on EN12102 standard measurements under EN14825 standard conditions.

Outdoor Unit:
WOYA060KLT

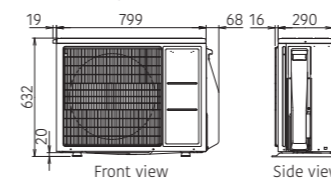

WOYA080KLT

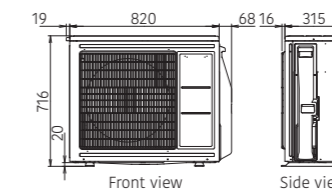

WOYA100KLT

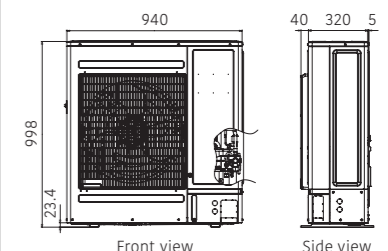

Split type
High power series (Wall-mounted type)

Indoor unit:
WSEG140MQ6
[3-phase] WSEK140MQ9
Outdoor unit:
WOYG100MQL / WOYG121MQL / WOYG140MQL
[3-phase] WOYK121MQL / WOYK140MQL



Specifications

Model Name	Indoor unit		Wall Mounted									
	Outdoor unit		WOYG100MQL	WOYG121MQL	WOYG140MQL	WOYK121MQL	WOYK140MQL					
Capacity Range			10	12	14	12	14					
7°C/35°C floor heating*1	Heating capacity (Max.)	kW	10.08 (15.3)	12.55 (16.2)	14.47 (17.8)	12.55 (16.2)	14.47 (17.8)					
	Input power (Max.)		2.18 (3.54)	2.69 (3.80)	3.36 (4.16)	2.69 (3.80)	3.36 (4.16)					
	COP (Max.)		4.62 (4.33)	4.67 (4.25)	4.31 (4.28)	4.67 (4.25)	4.31 (4.28)					
7°C/55°C radiator*1	Heating capacity (Max.)	kW	8.24 (12.3)	9.16 (13.7)	10.09 (15.5)	9.16 (13.7)	10.09 (15.5)					
	Input power (Max.)		2.79 (4.15)	3.06 (4.72)	3.36 (5.41)	3.06 (4.72)	3.36 (5.41)					
	COP (Max.)		2.95 (2.96)	2.99 (2.91)	3.00 (2.87)	2.99 (2.91)	3.00 (2.87)					
-7°C/55°C radiator*1	Heating capacity (Max.)	kW	7.10 (9.1)	8.63 (10.2)	10.28 (10.5)	8.63 (10.2)	10.28 (10.5)					
	Input power (Max.)		3.30 (4.26)	4.03 (4.84)	4.74 (4.99)	4.03 (4.84)	4.74 (4.99)					
	COP (Max.)		2.15 (2.14)	2.14 (2.12)	2.17 (2.11)	2.14 (2.12)	2.17 (2.11)					
Space heating characteristics*2			°C		55	35	55	35	55	35	55	35
Energy efficiency class			A++	A+++	A++	A+++	A++	A+++	A++	A+++	A++	A+++
Rated heat output (P _{rated})			kW		8.2	8.5	9.8	10.1	11.4	11.7	8.2	8.5
Seasonal space heating energy efficiency (η _s)			%		131	183	135	183	137	185	135	183
Annual energy consumption			kWh		5,060	3,771	5,879	4,476	5,132	5,879	4,476	
Sound power level*3			dB(A)		56		58		56		58	
Indoor unit specifications												
Power source			Single phase, 230 V, 50 Hz			3-phase, ~400 V, 50 Hz						
Dimensions H × W × D			mm		750 × 448 × 469	750 × 448 × 469	750 × 448 × 469	750 × 448 × 469	750 × 448 × 469			
Weight (Net)			kg		46	46	46	46	46			
Water circulation			Min./Max. L/min		10/42	10/42	10/42	10/42	10/42			
DHW tank volume			L		-	-	-	-	-			
Buffer tank capacity			L		15	15	15	15	15			
Expansion vessel capacity			L		12	12	12	12	12			
Water flow temperature range			Max. °C		60	60	60	60	60			
Water pipe connection diameter			Flow/Return mm		Ø19.05/Ø19.05	Ø19.05/Ø19.05	Ø19.05/Ø19.05	Ø19.05/Ø19.05	Ø19.05/Ø19.05			
Electrical heater capacity			Heating kW		6	6	6	9	9			
Outdoor unit specifications												
Power source			Single phase, 230 V, 50 Hz			3-phase, ~400 V, 50 Hz						
Current			Max. A		19.5	22.0	25.0	8.8	9.8			
Water flow temperature range			Max. °C		60	60	60	60	60			
Dimensions H × W × D			mm		1,008 × 1,080 × 480	1,008 × 1,080 × 480	1,008 × 1,080 × 480	1,008 × 1,080 × 480	1,008 × 1,080 × 480			
Weight (Net)			kg		96	96	102	96	102			
Refrigerant			Type (Global Warming Potential)		R32	R32	R32	R32	R32			
Additional refrigerant charge			Charge kg		1.40	1.40	1.63	1.40	1.63			
Connection pipe			Diameter mm		Ø6.35	Ø6.35	Ø6.35	Ø6.35	Ø6.35			
			Length (Pre-charge) m		3/25	3/25	3/25	3/25	3/25			
			Height difference Max. m		15	15	15	15	15			
Operating range			Heating °C		-25 to 35	-25 to 35	-25 to 35	-25 to 35	-25 to 35			

*1: Heating capacity, input power, and COP are measured using the EN14511 standard. Actual usage environments, such as the operating modes of the heating equipment, room temperature, and controller settings, may cause differences in values between those listed in the catalog and the actual performance characteristics.
*2: Information about ErP can be downloaded from our website at www.generalw.com/global/support/downloads/search/
*3: The sound power level values are based on EN12102 standard measurements under EN14825 standard conditions.

Dimensions

(Unit: mm)

Wall Mounted:
Single phase: WSEG140MQ6
3-phase: WSEK140MQ9

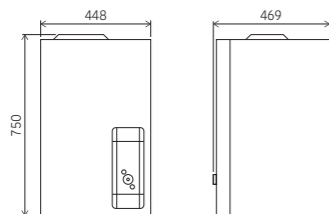

DHW Integrated:
Single phase: WGEK140MQ6-19
3-phase: WGEK140MQ9-19

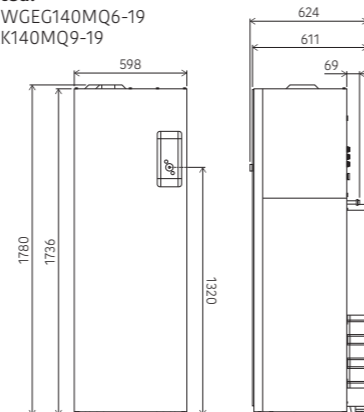

Split type
High power series (DHW Integrated type)

Indoor unit:
WGEK140MQ6-19
[3-phase] WGEK140MQ9-19
Outdoor unit:
WOYG100MQL / WOYG121MQL / WOYG140MQL
[3-phase] WOYK121MQL / WOYK140MQL



Specifications

Model Name	Indoor unit		DHW Integrated							
	Outdoor unit		WOYG100MQL	WOYG121MQL	WOYG140MQL	WOYK121MQL	WOYK140MQL			
Capacity Range			10	12	14	12	14			
7°C/35°C floor heating*1	Heating capacity (Max.)	kW	10.08 (15.3)	12.55 (16.2)	14.47 (17.8)	12.55 (16.2)	14.47 (17.8)			
	Input power (Max.)		2.18 (3.54)	2.69 (3.80)	3.36 (4.16)	2.69 (3.80)	3.36 (4.16)			
	COP (Max.)		4.62 (4.33)	4.67 (4.25)	4.31 (4.28)	4.67 (4.25)	4.31 (4.28)			
7°C/55°C radiator*1	Heating capacity (Max.)	kW	8.24 (12.3)	9.16 (13.7)	10.09 (15.5)	9.16 (13.7)	10.09 (15.5)			
	Input power (Max.)		2.79 (4.15)	3.06 (4.72)	3.36 (5.41)	3.06 (4.72)	3.36 (5.41)			
	COP (Max.)		2.95 (2.96)	2.99 (2.91)	3.00 (2.87)	2.99 (2.91)	3.00 (2.87)			
-7°C/55°C radiator*1	Heating capacity (Max.)	kW	7.10 (9.1)	8.63 (10.2)	10.28 (10.5)	8.63 (10.2)	10.28 (10.5)			
	Input power (Max.)		3.30 (4.26)	4.03 (4.84)	4.74 (4.99)	4.03 (4.84)	4.74 (4.99)			
	COP (Max.)		2.15 (2.14)	2.14 (2.12)	2.17 (2.11)	2.14 (2.12)	2.17 (2.11)			
Space heating characteristics*2			°C		55	35	55	35	55	35
Energy efficiency class			A++	A+++	A++	A+++	A++	A+++	A++	A+++
Rated heat output (P _{rated})			kW		8.2	8.5	9.8	10.1	11.4	11.7
Seasonal space heating energy efficiency (η _s)			%		131	183	135	183	137	185
Annual energy consumption			kWh		5,060	3,771	5,879	4,476	5,132	5,879
Sound power level*3			dB(A)		56		58		56	
Indoor unit specifications										
Power source			Single phase, 230 V, 50 Hz			3-phase, ~400 V, 50 Hz				
Dimensions H × W × D			mm		1,780 × 598 × 624	1,780 × 598 × 624	1,780 × 598 × 624	1,780 × 598 × 624	1,780 × 598 × 624	
Weight (Net)			kg		135	135	135	135	135	
Water circulation			Min./Max. L/min		10/42	10/42	10/42	10/42	10/42	
DHW tank volume			L		190	190	190	190	190	
Buffer tank capacity			L		16	16	16	16	16	
Expansion vessel capacity			L		12	12	12	12	12	
Water flow temperature range			Max. °C		60	60	60	60	60	
Water pipe connection diameter			Flow/Return mm		Ø19.05/Ø19.05	Ø19.05/Ø19.05	Ø19.05/Ø19.05	Ø19.05/Ø19.05	Ø19.05/Ø19.05	
Electrical heater capacity			Heating kW		6.0	6.0	6.0	9.0	9.0	
			DHW kW		1.2	1.2	1.2	1.2	1.2	
Declared load profile					L	L	L	L	L	
Efficiency ηDHW			%		116	116	116	116	116	
Heating up time			COP(EN16147)		1h30min	1h20min	1h10min	1h20min	1h10min	
					2.90	2.90	2.90	2.90	2.90	
Outdoor unit specifications										
Power source			Single phase, 230 V, 50 Hz			3-phase, ~400 V, 50 Hz				
Current			Max. A		19.5	22.0	25.0	8.8	9.8	
Water flow temperature range			Max. °C		60	60	60	60	60	
Dimensions H × W × D			mm		1,008 × 1,080 × 480	1,008 × 1,080 × 480	1,008 × 1,080 × 480	1,008 × 1,080 × 480	1,008 × 1,080 × 480	
Weight (Net)			kg		96	96	102	96	102	
Refrigerant			Type (Global Warming Potential)		R32	R32	R32	R32	R32	
Additional refrigerant charge			Charge kg		1.40	1.40	1.63	1.40	1.63	
Connection pipe			Diameter mm		Ø6.35	Ø6.35	Ø6.35	Ø6.35	Ø6.35	
			Length (Pre-charge) m		3/25	3/25	3/25	3/25	3/25	
			Height difference Max. m		15	15	15	15	15	
Operating range			Heating °C		-25 to 35	-25 to 35	-25 to 35	-25 to 35	-25 to 35	

*1: Heating capacity, input power, and COP are measured using the EN14511 standard. Actual usage environments, such as the operating modes of the heating equipment, room temperature, and controller settings, may cause differences in values between those listed in the catalog and the actual performance characteristics.
*2: Information about ErP can be downloaded from our website at www.generalw.com/global/support/downloads/search/
*3: The sound power level values are based on EN12102 standard measurements under EN14825 standard conditions.

Outdoor Unit:
Single phase: WOYG100MQL/WOYG121MQL/WOYG140MQL
3-phase: WOYK121MQL/WOYK140MQL

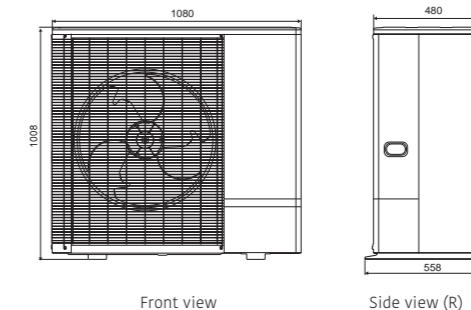

Split type
High power series (Wall-mounted type)

Indoor unit:
WSYG140DG6/
[3-phase]WSYK160DG9

Outdoor unit:
WOYG112LHT / WOYG140LCTA
[3-phase] WOYK112LCTA /
WOYK140LCTA /WOYK160LCTA



Specifications

Model Name	Indoor unit	WSYG140DG6	WSYG140DG6	WSYK160DG9	WSYK160DG9	WSYK160DG9
	Outdoor unit	WOYG112LHT	WOYG140LCTA	WOYK112LCTA	WOYK140LCTA	WOYK160LCTA
Capacity range		11	14	11	14	16
7°C/35°C floor heating *1	Heating capacity	10.80	13.50	10.80	13.50	15.17
	Input power	2.54	3.23	2.51	3.20	3.70
	COP	4.25	4.18	4.30	4.22	4.10
2°C/35°C floor heating *1	Heating capacity	10.77	12.00	10.77	13.00	13.50
	Input power	3.44	3.87	3.40	4.15	4.34
	COP	3.13	3.10	3.17	3.13	3.11
-7°C/35°C floor heating*1	Heating capacity	10.38	11.54	10.38	12.20	13.50
	Input power	4.32	5.08	4.28	5.13	5.40
	COP	2.40	2.27	2.43	2.38	2.50
-7°C/55°C Radiator*1	Heating capacity	7.57	9.20	9.27	10.10	11.00
	Input power	4.57	5.08	5.09	5.65	6.29
	COP	1.66	1.81	1.82	1.79	1.75
Space heating characteristics*2						
Temperature application	°C	55	35	55	35	55
Energy efficiency class		A+	A++	A+	A++	A+
Rated heat output (P _{rated})	kW	9	11	11	13	13
Seasonal space heating energy efficiency (η _s)	%	112	151	113	148	117
Annual energy consumption	kWh	6,704	6,062	8,041	6,824	6,669
Sound power level	Indoor unit	46	46	46	46	46
	Outdoor unit	68	69	69	68	71
Indoor unit specifications						
Power source		Single phase, ~230 V, 50 Hz			3-phase, ~400 V, 50 Hz	
Dimensions H × W × D	mm	800 × 450 × 457			800 × 450 × 457	
Weight (Net)	kg	42			42	
Water circulation	Min./Max.	L/min	19.5/39.0	24.4/48.7	19.5/39.0	24.4/48.7
Buffer tank capacity	L		16		16	
Expansion vessel capacity	L		8		8	
Water flow temperature range	Max.	°C	60		60	
Water pipe connection diameter	Flow/Return	mm	Ø25.4/Ø25.4		Ø25.4/Ø25.4	
Electrical heater capacity	heating	kW	6.0(3.0 kW×2pcs.)		9.0(3.0 kW×3pcs.)	
Outdoor unit specifications						
Power source		Single phase, ~230 V, 50 Hz			3-phase, ~400 V, 50 Hz	
Current	Max.	A	22.0	25.0	9.0	9.5
Dimensions H × W × D	mm	1,290 × 900 × 330			1,290 × 900 × 330	
Weight (Net)	kg	92			99	
Refrigerant	Type (Global Warming Potential)	R410A (2,088)				
Additional refrigerant charge	Charge	kg	2.50			
Connection pipe	Diameter	Liquid	Ø9.52			
		Gas	Ø15.88			
	Length	Min./Max.	5/20			
	Length (Pre-charge)	m	15			
Operating range	Height difference	Max.	15			
	Heating	°C	-25 to 35			

*1: Heating capacity, input power, and COP are measured using the EN14511 standard. Actual usage environments, such as the operating modes of the heating equipment, room temperature, and controller settings, may cause differences in values between those listed in the catalog and the actual performance characteristics.

*2: Information about ErP can be downloaded from our website at www.generalww.com/global/support/downloads/search/

Dimensions

(Unit: mm)

Indoor Unit:
Single phase: WSYG140DG6
3-phase: WSYK160DG9

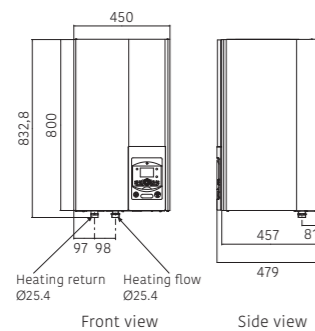

Single phase: WGYG140DG6
3-phase: WGYK160DG9

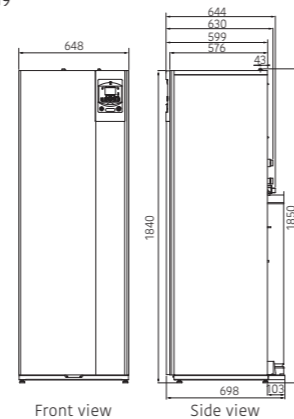

Split type
High power series (DHW Integrated type)

Indoor unit:
WGYG140DG6/
[3-phase]WGYK160DG9

Outdoor unit:
WOYG112LHT / WOYG140LCTA
[3-phase] WOYK112LCTA / WOYK140LCTA /
WOYK160LCTA



Specifications

Model Name	Indoor unit	WGYG140DG6	WGYG140DG6	WGYK160DG9	WGYK160DG9	WGYK160DG9
	Outdoor unit	WOYG112LHT	WOYG140LCTA	WOYK112LCTA	WOYK140LCTA	WOYK160LCTA
Capacity range		11	14	11	14	16
7°C/35°C floor heating *1	Heating capacity	10.80	13.50	10.80	13.50	15.17
	Input power	2.54	3.23	2.51	3.20	3.70
	COP	4.25	4.18	4.30	4.22	4.10
2°C/35°C floor heating *1	Heating capacity	10.77	12.00	10.77	13.00	13.50
	Input power	3.44	3.87	3.40	4.15	4.34
	COP	3.13	3.10	3.17	3.13	3.11
-7°C/35°C floor heating*1	Heating capacity	10.38	11.54	10.38	12.20	13.50
	Input power	4.32	5.08	4.28	5.13	5.40
	COP	2.40	2.27	2.43	2.38	2.50
-7°C/55°C Radiator*1	Heating capacity	7.57	9.20	9.27	10.10	11.00
	Input power	4.57	5.08	5.09	5.65	6.29
	COP	1.66	1.81	1.82	1.79	1.75
Space heating characteristics*2						
Temperature application	°C	55	35	55	35	55
Energy efficiency class		A+	A++	A+	A++	A+
Rated heat output (P _{rated})	kW	9	11	11	13	13
Seasonal space heating energy efficiency (η _s)	%	112	151	113	148	117
Annual energy consumption	kWh	6,704	6,062	8,041	6,824	6,669
Sound power level	Indoor unit	46	46	46	46	46
	Outdoor unit	68	69	69	68	71
Domestic hot water characteristics*2						
Load profile		L				
Energy efficiency class		A				
Energy efficiency (η _{dw})	%	88				
Annual electricity consumption	kWh	1166				
Indoor unit specifications						
Power source		Single phase, ~230 V, 50 Hz			3-phase, ~400 V, 50 Hz	
Dimensions H × W × D	mm	1,840 × 648 × 698			1,840 × 648 × 698	
Weight (Net)	kg	152			152	
Water circulation	Min./Max.	L/min	19.5/39.0	24.4/28.7	19.5/39.0	24.4/48.7
DHW tank volume	L		190		190	
Electrical heater capacity	Heating	kW	6		9	
	DHW	kW				
Buffer tank capacity	L		1.5		1.5	
Expansion vessel capacity	L		16		16	
Water flow temperature range	Max.	°C	60			
Water pipe connection diameter	Flow/Return	mm	Ø25.4/Ø25.4			
Hot water pipe connection diameter	mm		Ø19.05			
Outdoor unit specifications						
Power source		Single phase, ~230 V, 50 Hz			3-phase, ~400 V, 50 Hz	
Current	Max.	A	22.0	25.0	9.0	9.5
Dimensions H × W × D	mm	1,290 × 900 × 330			1,290 × 900 × 330	
Weight (Net)	kg	92			99	
Refrigerant	Type (Global Warming Potential)	R410A (2,088)				
Additional refrigerant charge	Charge	kg	2.50			
Connection pipe	Diameter	Liquid	Ø9.52			
		Gas	Ø15.88			
	Length	Min./Max.	5/20			
	Length (Pre-charge)	m	15			
Operating range	Height difference	Max.	15			
	Heating	°C	-25 to 35			

*1: Heating capacity, input power, and COP are measured using the EN14511 standard. Actual usage environments, such as the operating modes of the heating equipment, room temperature, and controller settings, may cause differences in values between those listed in the catalog and the actual performance characteristics.

*2: Information about ErP can be downloaded from our website at www.generalww.com/global/support/downloads/search/

Outdoor Unit:
Single phase: WOYG112LHT/WOYG140LCTA

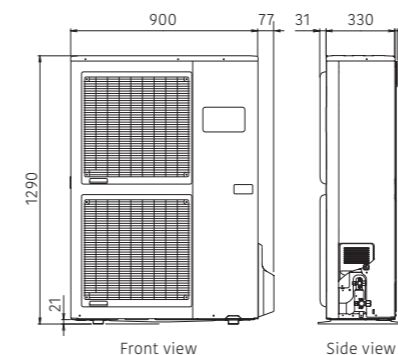

3-phase: WOYK112LCTA/WOYK140LCTA/WOYK160LCTA

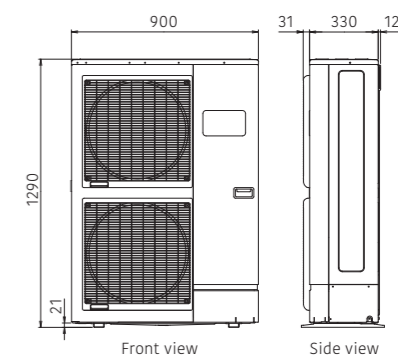

Split type
Super high power series (Wall-mounted type)

Indoor unit:
WSYG160DJ6 / [3-phase] WSYK170DJ9

Outdoor unit:
WOYG160LJL
[3-phase] WOYK150LJL / WOYK170LJL



Specifications

Model Name	Indoor unit	Outdoor unit	WSYG160DJ6	WSYK170DJ9	WSYK170DJ9
Capacity range			WOYG160LJL	WOYK150LJL	WOYK170LJL
		16		15	
7°C/35°C floor heating*1	Heating capacity	kW	16.00	15.00	17.00
	Input power		3.86	3.46	4.10
	COP		4.15	4.33	4.15
2°C/35°C floor heating*1	Heating capacity	kW	13.30	13.20	13.50
	Input power		4.25	4.06	4.27
	COP		3.13	3.25	3.16
-7°C/35°C floor heating*1	Heating capacity	kW	14.50	13.20	15.00
	Input power		5.27	4.55	5.32
	COP		2.75	2.90	2.82
-7°C/55°C Radiator*1	Heating capacity	kW	10.90	13.20	14.20
	Input power		5.89	6.77	7.40
	COP		1.85	1.95	1.92
Space heating characteristics*2					
Temperature application	°C		55	35	55
Energy efficiency class			A++	A++	A++
Rated heat output (P _{rated})	kW		14	16	17
Seasonal space heating energy efficiency (η _s)	%		125	163	130
Annual energy consumption	kWh		8,757	8,014	9,059
Sound power level	Indoor unit	dB(A)	45	45	45
	Outdoor unit		67	66	67
Indoor unit specifications					
Power source			Single phase, ~230 V, 50 Hz		3-phase, ~400 V, 50 Hz
Dimensions H × W × D	mm		805 × 450 × 471		805 × 450 × 471
Weight (Net)	kg		52.5		52.5
Water circulation	Min./Max.	L/min	26.4/57.8		24.0/54.2
Buffer tank capacity	L		22		22
Expansion vessel capacity	L		10		10
Water flow temperature range	Max.	°C	60		60
Water pipe connection diameter	Flow/Return	mm	Ø25.4/Ø25.4		Ø25.4/Ø25.4
Electrical heater capacity	Heating	kW	6.0 (3.0 kW × 2 pcs.)		9.0 (3.0 kW × 3 pcs.)
Outdoor unit specifications					
Power source			Single phase, ~230 V, 50 Hz		3-phase, ~400 V, 50 Hz
Current	Max.	A	28.0		14.0
Dimensions H × W × D	mm		1,428 × 1,080 × 480		1,428 × 1,080 × 480
Weight (Net)	kg		137		138
Refrigerant	Type (Global Warming Potential)	R410A (2,088)			
Additional refrigerant charge	Charge	kg	3.80		3.80
Connection pipe	Diameter	Liquid	Ø9.52		Ø9.52
	Gas	mm	Ø15.88		Ø15.88
	Length	Min./Max.	5/30		5/30
	Length (Pre-charge)	m	15		15
Operating range	Height difference	Max.	25/15 (Outdoor unit: Upper/Lower)		25/15
	Heating	°C	-25 to 35		-25 to 35

*1: Heating capacity, input power, and COP are measured using the EN14511 standard. Actual usage environments, such as the operating modes of the heating equipment, room temperature, and controller settings, may cause differences in values between those listed in the catalog and the actual performance characteristics.
*2: Information about ErP can be downloaded from our website at www.generalwv.com/global/support/downloads/search/

Dimensions

(Unit: mm)

Indoor Unit:
Single phase: WSYG160DJ6
3-phase: WSYK170DJ9

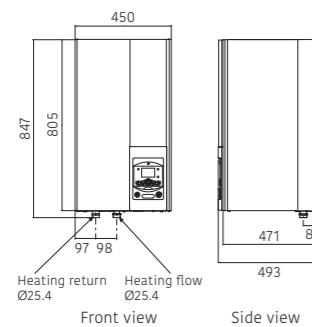

Single phase: WGYG160DJ6
3-phase: WGYK170DJ9

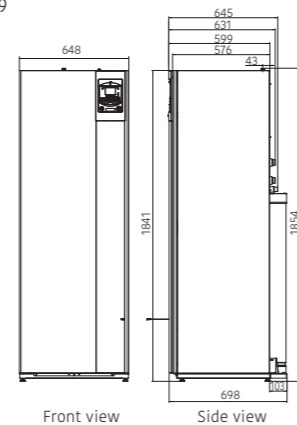

Split type
Super high power series (DHW Integrated type)

Indoor unit:
WGYG160DJ6 / [3-phase] WGYK170DJ9

Outdoor unit:
WOYG160LJL
[3-phase] WOYK150LJL / WOYK170LJL



Specifications

Model Name	Indoor unit	Outdoor unit	WGYG160DJ6	WGYK170DJ9	WGYK170DJ9
Capacity range			WOYG160LJL	WOYK150LJL	WOYK170LJL
		16		15	
7°C/35°C floor heating*1	Heating capacity	kW	16.00	15.00	17.00
	Input power		3.86	3.46	4.10
	COP		4.15	4.33	4.15
2°C/35°C floor heating*1	Heating capacity	kW	13.30	13.20	13.50
	Input power		4.25	4.06	4.27
	COP		3.13	3.25	3.16
-7°C/35°C floor heating*1	Heating capacity	kW	14.50	13.20	15.00
	Input power		5.27	4.55	5.32
	COP		2.75	2.90	2.82
-7°C/55°C Radiator*1	Heating capacity	kW	10.90	13.20	14.20
	Input power		5.89	6.77	7.40
	COP		1.85	1.85	1.92
Space heating characteristics*2					
Temperature application	°C		55	35	55
Energy efficiency class			A++	A++	A++
Rated heat output (P _{rated})	kW		14	16	17
Seasonal space heating energy efficiency (η _s)	%		125	163	130
Annual energy consumption	kWh		8,757	8,014	9,059
Sound power level	Indoor unit	dB(A)	45	45	45
	Outdoor unit		67	66	67
Domestic hot water characteristics*2					
Load profile			L		
Energy efficiency class			A		
Energy efficiency (η _{DHW})	%		109		
Annual electricity consumption	kWh		941		
Indoor unit specifications					
Power source			Single phase, ~230 V, 50 Hz		3-phase, ~400 V, 50 Hz
Dimensions H × W × D	mm		1,841 × 648 × 698		1,841 × 648 × 698
Weight (Net)	kg		166		166
Water circulation	Min./Max.	L/min	26.4/57.8		24.0/54.2
DHW tank volume	L		190		190
Electrical heater capacity	Heating	kW	6.0 (3.0 kW × 2 pcs.)		9.0 (3.0 kW × 3 pcs.)
Buffer tank capacity	L		1.5		1.5
Expansion vessel capacity	L		22		22
Water flow temperature range	Max.	°C	60		60
Water pipe connection diameter	Flow/Return	mm	Ø25.4/Ø25.4		Ø25.4/Ø25.4
Hot water pipe connection diameter	mm		Ø19.05		Ø19.05
Outdoor unit specifications					
Power source			Single phase, ~230 V, 50 Hz		3-phase, ~400 V, 50 Hz
Current	Max.	A	28.0		14.0
Dimensions H × W × D	mm		1,428 × 1,080 × 480		1,428 × 1,080 × 480
Weight (Net)	kg		137		138
Refrigerant	Type (Global Warming Potential)	R410A (2,088)			
Additional refrigerant charge	Charge	kg	3.80		3.80
Connection pipe	Diameter	Liquid	Ø9.52		Ø9.52
	Gas	mm	Ø15.88		Ø15.88
	Length	Min./Max.	5/30		5/30
	Length (Pre-charge)	m	15		15
Operating range	Height difference	Max.	25/15 (Outdoor unit: Upper/Lower)		25/15 (Outdoor unit: Upper/Lower)
	Heating	°C	-25 to 35		-25 to 35

*1: Heating capacity, input power, and COP are measured using the EN14511 standard. Actual usage environments, such as the operating modes of the heating equipment, room temperature, and controller settings, may cause differences in values between those listed in the catalog and the actual performance characteristics.
*2: Information about ErP can be downloaded from our website at www.generalwv.com/global/support/downloads/search/

Outdoor Unit:
Single phase: WOYG160LJL
3-phase: WOYK150LJL/WOYK170LJL

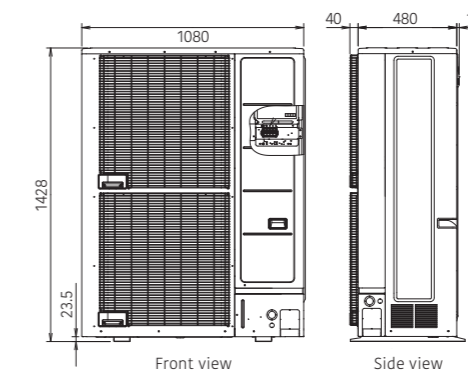



Indoor Unit

Type-A
Type-B

Selecting the indoor unit

- This is a device for storing hot water and circulating it to housing equipment.
- Selection criteria for the indoor unit is which housing equipment it will be connected to, such as a radiator or shower.
- Indoor unit you choose will also depend on whether you already own devices such as a pump or tank.



Radiator, Fan coil



Shower, Bath

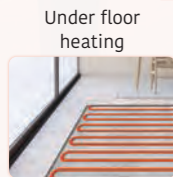

Under floor heating

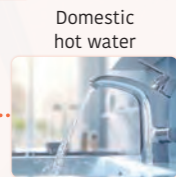

Domestic hot water



What Each Indoor Unit Can Do



Indoor unit control box*

If you want to update your system by reusing your existing pump and buffer tank, etc., you can do so by installing only the control box.



Indoor unit Wall-mounted

Stands for preparation of heating water for under floor heating and radiators. It can optionally operate with domestic hot water tank.



Indoor unit Domestic Hot Water (DHW) integrated

Can be used with a variety of heating systems, including under floor heating and radiators. Space saving heating and DHW supply in a single indoor unit.

*The control box can only be selected for Monobloc outdoor unit.

Types of Indoor Units



Compatibility for Monobloc type Comfort series / Split type High power series*

*The R32 High Power Series cannot be connected to the control box.



Indoor unit type	Control box*	Wall-mounted	DHW integrated
Housing Equipment			
Under floor heating	○	●	●
Radiator	○	●	●
Fan coil	○	●	●
Bath	○	○	●
Shower	○	○	●
Hot Water	○	○	●



Compatibility for Split type Comfort series, High power series Super high power series



Indoor unit type	Wall-mounted	DHW integrated
Housing Equipment		
Under floor heating	●	●
Radiator	●	●
Fan coil	●	●
Bath	○	●
Shower	○	●
Hot water	○	●

● : It can be used by constructing a system using options and carrying out water pipe work.

○ : It can be used by constructing a system using options and carrying out water pipe work, by reusing (or locally procuring) existing pumps and tanks, etc.

Housing Equipment requires the preparation of separately sold products.

Type-A

Comfort Control

Useful Features

Flow temperature control with climate compensation

Automatic Heating Curve Control

Automatic temperature regulation according to heating curve (depending on heating terminal and outdoor temperature)

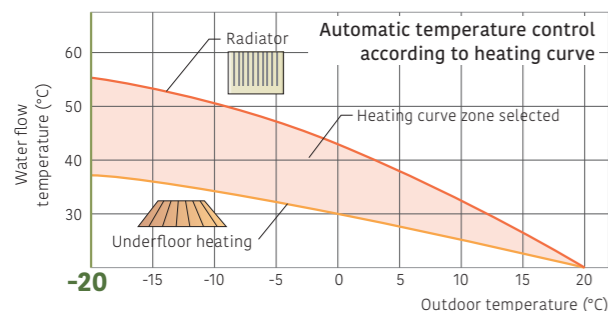

Auto Changeover

When Auto mode is selected, the system automatically switches between cooling and heating modes depending on the outdoor temperature to serve as an all-season air conditioner.

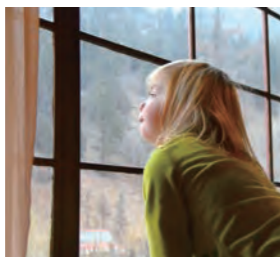

Quick Recovery from Defrosting

Maintains room temperature by boost start operation during defrosting.

2-zone Independent Control

2-zone independent control (For example, the individual control of 2 underfloor heating zones or the combination of 1 underfloor heating zone and 1 radiator zone)**2

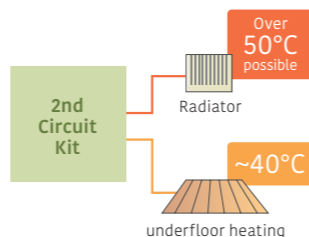

*1: Optional parts such as 2-zone kits, 3-zone kits, and thermostats are required
*2: 3 Zones can be controlled in the Control Box

Backup Heater Operation

Backup heater maintains a comfortable room temperature even when the outside temperature is low. The backup heater is intelligently controlled as a safety backup for very cold days and nights, and only operates when really needed.

Controller with a clear color display and simple icons for easy function settings

Color display

Shows all the information items related to the operation mode:
WLAN Connectivity / Operation / Pressure / Set temperature (DHW/Flow) Clock / Message / Service maintenance



Operation indicator
Fixed white: Normal operation
Flashing orange: Error

Menu access button

Navigation knob:
Rotation: Menu navigation
Press: Validation

Back button

Main operation flow and settings for installers and end users

	Flow Chart	Example Item
Installers	1 Install Settings	Pump speed setting, Configuration, Heating curve setting, Heat pump shut off
	2 Option Settings	Cooling Kit, DHW Kit, Boiler Kit
	3 Convenient Function	Automatic heating curve settings, Underfloor controlled driving, Outdoor temperature adjustment, Maintenance period settings
	4 Workout Settings	Outdoor temperature simulator
	5 Confirmation	Checking operation (Heating and cooling, DHW, option)
End users	6 User Settings	Date and time, Time program, Operation temperature settings

Energy Saving

Away mode

It will set heating and DHW mode to the frost protection* during the selected period:

-If you activate away mode on HMI: You can choose start and end time/date.

-If you activate away mode on Room thermostat (option): You can choose start and end time/date, as well as room setpoint during away period.

*: The protection mode automatically prevents an excessively sharp drop in room temperature.

Safety Features

Anti-freeze function*

When the outside temperature drops below a specified level, the outdoor unit water pump will self-activate and water will also be automatically circulated to prevent freezing.

*The R32 High Power Series is excluded.

Easy Installation & Maintenance

- All hydraulic safety and control components are built in with no additional selection required.
- Easy access for maintenance
- Refrigerant pump down operation

Error and Maintenance Alarm

Enables quick error-handling services and maintenance

✖ Error ⚠ Warning



Maintenance Support

Diagnostics functions for troubleshooting



Easy to Set Up

Easy Start

Choose language, set date and time. Answer questions from Easy Start.

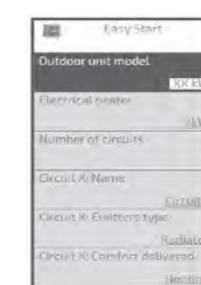

Remote Connectivity and Control

Via app "Cozy touch", you can manage and control of electric heaters, electric water heaters, heat pump water heaters, heat pumps.

* Cozytouch is a service of Group Atlantic



Type-A

Optional Parts & Control Overview

To meet the diverse needs of customers, we offer a variety of control options, such as individual control and remote control options.

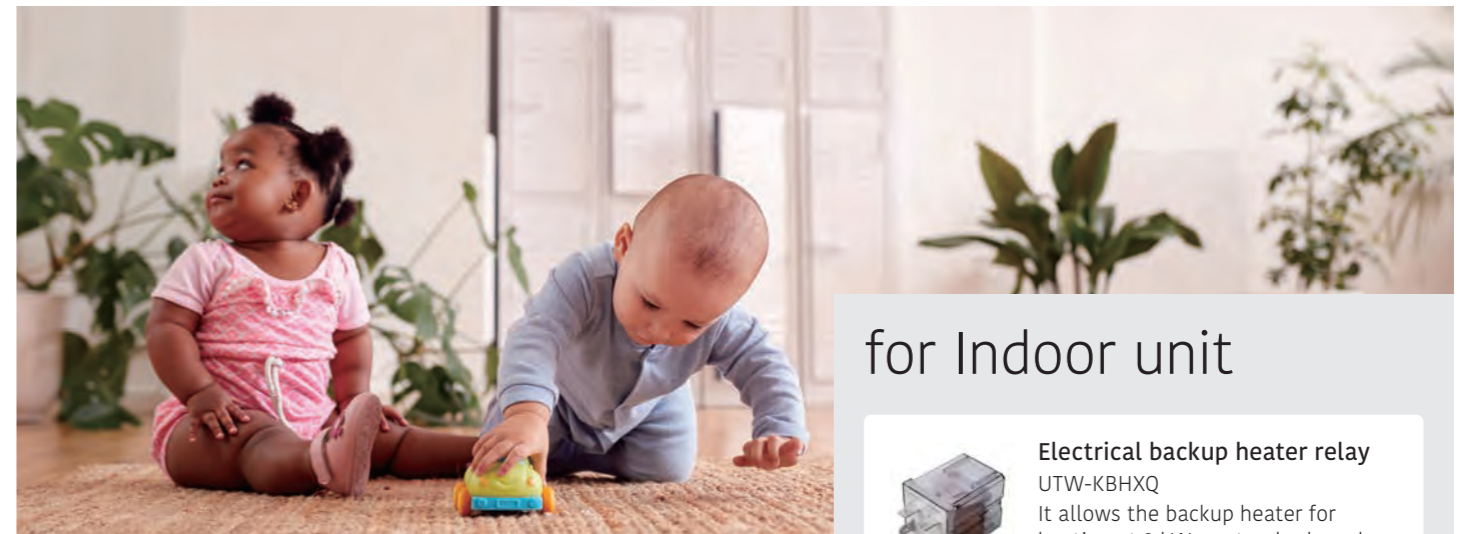

for Locally units

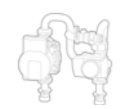

Second Circuit Kit

It can supply hot water at different temperatures to each two types of heating equipment, such as radiators and underfloor heating.

UTW-KZSXQ



UTW-KZC2XQ

UTW-KZDXQ

Boiler Connection Kit

It can build hybrid systems using both boilers and heat pumps. Boiler and heat pumps are switched according to outside air temperature.



UTW-KBCXQ

for DHW



DHW Kit

Required to connect locally purchased DHW tanks to Air to Water.

UTW-KDWXQ

UTW-KDWCXQ



DHW tank

200 Liters: UTW-T20AXH / UTW-T20BXH
300 Liters: UTW-T30AXH / UTW-T30BXH
The BXH series is a more efficient tank than the AXH series.



DHW Expansion Kit

UTW-KDEXQ
The expansion vessel(18L) for connection to DHW water pipe.

Service & Maintenance Tool

Service Monitor Tool

UTY-ASSXZ1



for Indoor unit



Electrical backup heater relay

UTW-KBHXQ

It allows the backup heater for heating at 3 kW as standard can be used at 6 kW.

for Outdoor unit



Drain pan

UTW-KDPXQ

It is used to collect and drain condensation water generated by outdoor unit.



Antivibration Rubber feet

UTW-KARXQ

It reduces vibration caused by the operation of compressors and other equipment, and suppresses the generation of noise.



Antifreezing valve for Monobloc

UTW-KAVXQ

When water pipes freeze, the internal pressure increases and the pipes are purged to prevent parts from breaking.

Individual Control

Room thermostat

An optional wireless thermostat allows remote control of the ATW system away from the indoor unit. Can also be operated from mobile apps.



Wired power supply
UTW-C225XQ



Battery power supply
UTW-C228XQ

Cozy tough (Application)

* Cozytouch is a service of Group Atlantic

















Wall-mounted













Indoor unit Controller

DHW Integrated

Monobloc type Comfort series

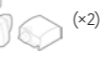
Type-A Optional Parts List

Product Name	Model Name	Monobloc Type				Split Type		
		Comfort series				High Power Series		
		1Ø				1Ø/3Ø		
		Controll Box	Wall-mounted	DHW integrated	Outdoor Unit	Wall-mounted	DHW integrated	Outdoor Unit
Second Circuit Kit 	UTW-KZSXQ		•*			•*		
DHW Kit 	UTW-KDWXQ		•			•		
Boiler Kit 	UTW-KBSXS					•		
Boiler Connection Kit 	UTW-KBDXS					•		
Second Circuit Kit 	UTW-KZDXQ			•*		•*		
DHW Loop Kit 	UTW-KDLXQ			•		•		
DHW Expansion Kit 	UTW-KDEXQ			•		•		
Outdoor temperature sensor 	UTW-KESXQ	•	•	•		•	•	
Condensation detection kit 	UTW-KCDXQ	•	•	•		•	•	
Regulation Extension Kit 	UTW-KREXQ	•	•	•		•	•	
Electrical Backup heater relay 	UTW-KBHXQ		•	•				
Room thermostat (Wired)  <small>Wired power supply</small>	UTW-C105XQ	•	•	•		•	•	
Room thermostat (Wireless) 	UTW-C225XQ	•	•	•		•	•	
	UTW-C228XQ	•	•	•		•	•	
Cover Plate for thermostat 	UTW-KCPXQ	•	•	•		•	•	
Dual circuit decoupling kit 	UTW-KZVXS					•	•	

Product Name	Model Name	Monobloc Type				Split Type		
		Comfort series				High Power Series		
		1Ø				1Ø/3Ø		
		Controll Box	Wall-mounted	DHW integrated	Outdoor Unit	Wall-mounted	DHW integrated	Outdoor Unit
Flow kit 	UTW-PHFXS					•	•	
High flow kit 	UTW-PHFXS					•	•	
Drain pan 	UTW-KDPXQ					•	•	
Antivibration Rubber feet 	UTW-KARXQ					•	•	
Antifreezing valve for Monobloc 	UTW-KAVXQ					•		
Single Circuit Kit  (x1)	UTW-KZC1XQ	•						
Second Circuit Kit  (x2)	UTW-KZC2XQ	•						
		 (x1)	•					
Third Circuit Kit  (x2)	UTW-KZC3XQ	•						
		 (x1)	•					
Boiler Connection Kit 	UTW-KBCXQ	•						
DHW Kit 	UTW-KDWCXQ	•						
Backup Heater Kit 	UTW-HB6CXQ	•						
DHW tank 	UTW-T20AXH UTW-T30AXH	•	•			•		
	UTW-T20BXH UTW-T30BXH	•	•			•		

*1: Regulation extension kit (UTW-KREXQ) is not included but is required for connection.

Type-**B**

Comfort Control

The high-grade heating controller automatically adjusts the flow temperature according to the climate conditions to maintain the room and domestic hot water temperatures at the desired levels.

Indoor unit Controller

4 Heating modes

1. Automatic mode

Enables automatic switching between Comfort mode and Reduce mode according to time program

2. Reduce mode

Maintains water temperature at a lower level

3. Comfort mode

Maintains water temperature at a comfortable level

4. Protection mode

Activates frost protection in standby operation



Useful Features

Automatic Heating Curve Control

Automatic temperature regulation according to heating curve (depending on heating terminal and outdoor temperature)

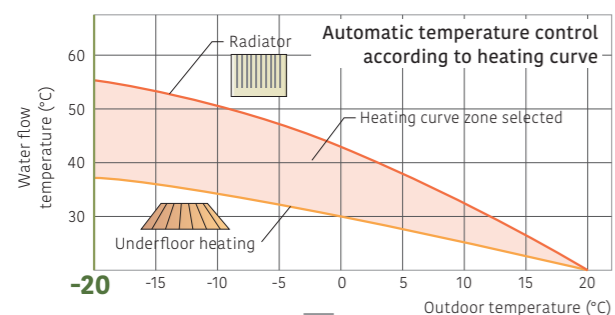

The heating curve will shift to adjust the room temperature setting.

Can be fine-adjusted when it is too warm or too cold.

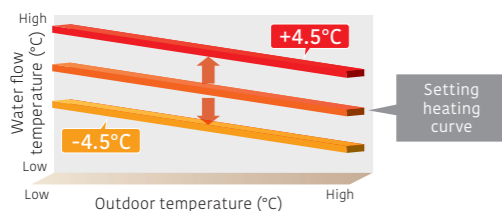

Quick Recovery from Defrosting

Maintains room temperature by boost start operation during defrosting.

Auto Changeover

When cooling mode is selected, the system automatically switches between cooling and heating modes depending on the outdoor temperature to serve as an all-season air conditioner.

2-Zone Independent Control

2-zone independent control (For example, the individual control of 2 underfloor heating zones or the combination of 1 underfloor heating zone and 1 radiator zone)^{*1}

*1: Optional parts required

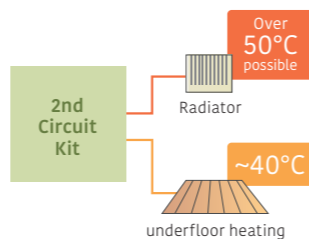

2-Stage Low-Noise Mode

The outdoor unit can be switched to quiet mode, depending on the installation environment.
*Effective only for high power series

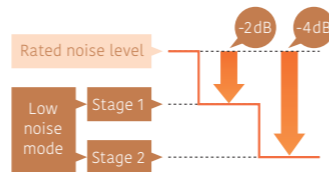

Backup Heater Operation

Backup heater maintains a comfortable room temperature even when the outside temperature is low. The backup heater is intelligently controlled as a safety backup for very cold days and nights, and only operates when really needed.

* Optional parts is needed for high power series.

Energy Saving

Time Program

- The timer is easy to set.
- You can select the heating mode in conjunction with various times of the day.

Day-weekly timer

- Allows up to 3 settings per day.
- Allows individual settings for each day of the week.

Holiday timer

- Allows up to 8 settings.
- While you are away from home for an extended period during winter, the system prevents your room or house from freezing.

Peak Cut Function^{*2}

Sets the peak current value to reduce power consumption.

Mode	Ratio to reduce power consumption
1	100%
2	75%
3	50%
4	Almost 0%

* Please refer to page W-054 and W-055 for optional parts information.

Safety Features

Anti-Legionella Function

Prevents the growth of Legionella bacteria in the DHW tank to supply safe and clean hot water at all times.

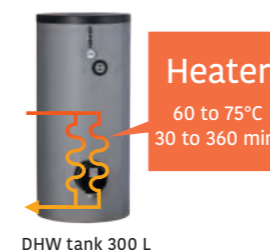

Anti-Freeze Function

When the outside temperature drops below a specified level, the compressor will self-activate and water will also be automatically circulated to prevent freezing.

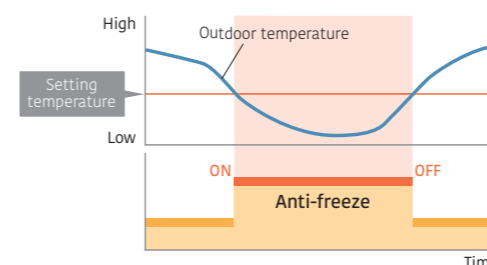

Emergency Operation

If an outdoor unit fails to operate, a built-in backup heater or an external boiler is activated to supply an uninterrupted supply of hot water to the house.

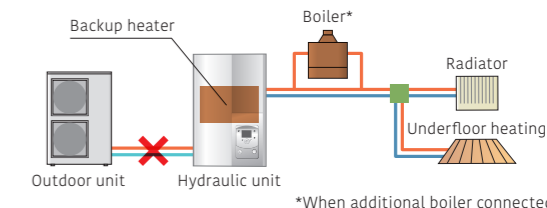

Error and Maintenance Alarm

Enables quick error-handling services and maintenance



- Error history saves 10 errors in memory
- Display telephone number of service company

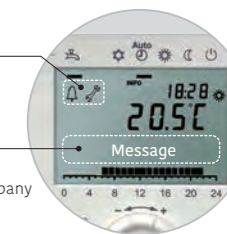

Type-**B**

Simple Installation

Presetting Configurations

A controller installed makes it easy to configure the system without having to set each component or unit individually.

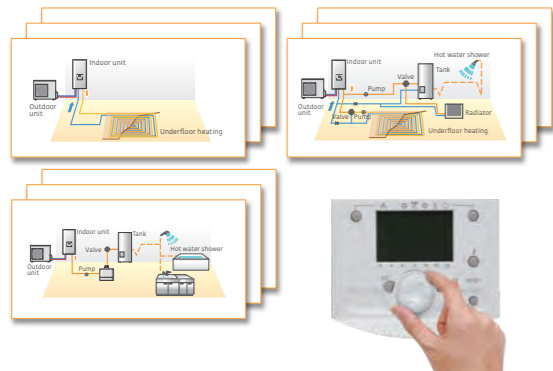

8 simple patterns for system presetting (Pair of heating: 12 patterns)

Configuration (Parameter 5700)	Installation type
Presetting 1	1 heating circuit
Presetting 2	2 heating circuits
Presetting 3	1 heating circuit with boiler backup
Presetting 4	2 heating circuits with boiler backup
Presetting 5	1/2 heating circuit with buffer control
Presetting 6	1/2 heating circuit with buffer control and boiler backup
Presetting 7	Cascade connection Primary
Presetting 8	Cascade connection A
Presetting 9	Cascade connection B/C

- DHW & solar control auto detection
- Cascade connection only available in High Power models.

Outdoor Temperature Simulation

It verifies that each unit operates properly under the set conditions and expected outdoor air temperature when the system is actually assembled.

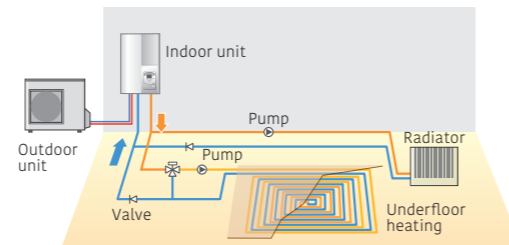

The outdoor temperatures can be simulated in the range of -50°C to +50°C.

Concrete Floor Drying

Allows the concrete surrounding the hot-water pipes to dry more quickly, shortening the construction period for underfloor heating installations.

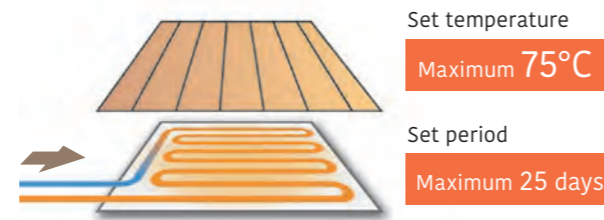

Set temperature
Maximum 75°C

Set period
Maximum 25 days

Controller with a large liquid crystal display and buttons for easy function settings

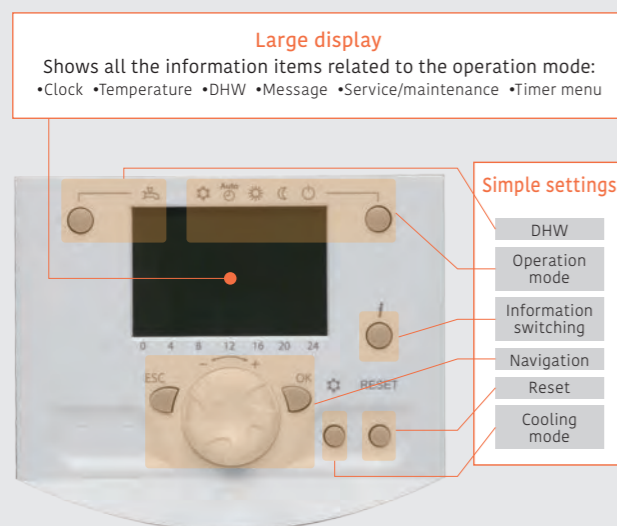

Simple settings

- DHW
- Operation mode
- Information switching
- Navigation
- Reset
- Cooling mode

Main operation flow and settings for installers and end users

	Flow Chart	Example Item
Installers	1 Install Settings	Pump speed setting, Configuration, Heating curve setting, Heat pump shut off
	2 Option Settings	Cooling Kit, DHW Kit, Boiler Kit
	3 Convenient Function	Automatic heating curve settings, Underfloor controlled driving, Outdoor temperature adjustment, Maintenance period settings
	4 Workout Settings	Outdoor temperature simulator
	5 Confirmation	Checking operation (Heating and cooling, DHW, option)
End users	6 User Settings	Date and time, Time program, Operation temperature settings

Easy Installation & Maintenance

- All hydraulic safety and control components are built in with no additional selection required.
- Lifting bars for installation free of difficulty or risk
- Easy access for maintenance
- Refrigerant pump down operation

Maintenance Support

Diagnostics functions for troubleshooting

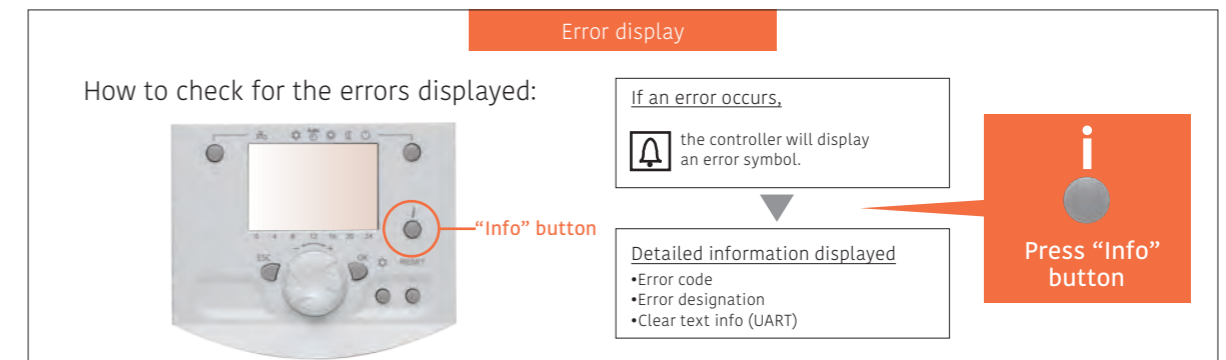

Check the error code table

Type-**B**

Control Overview

To meet the diverse needs of customers, we offer a variety of control options, such as individual control and remote control options.

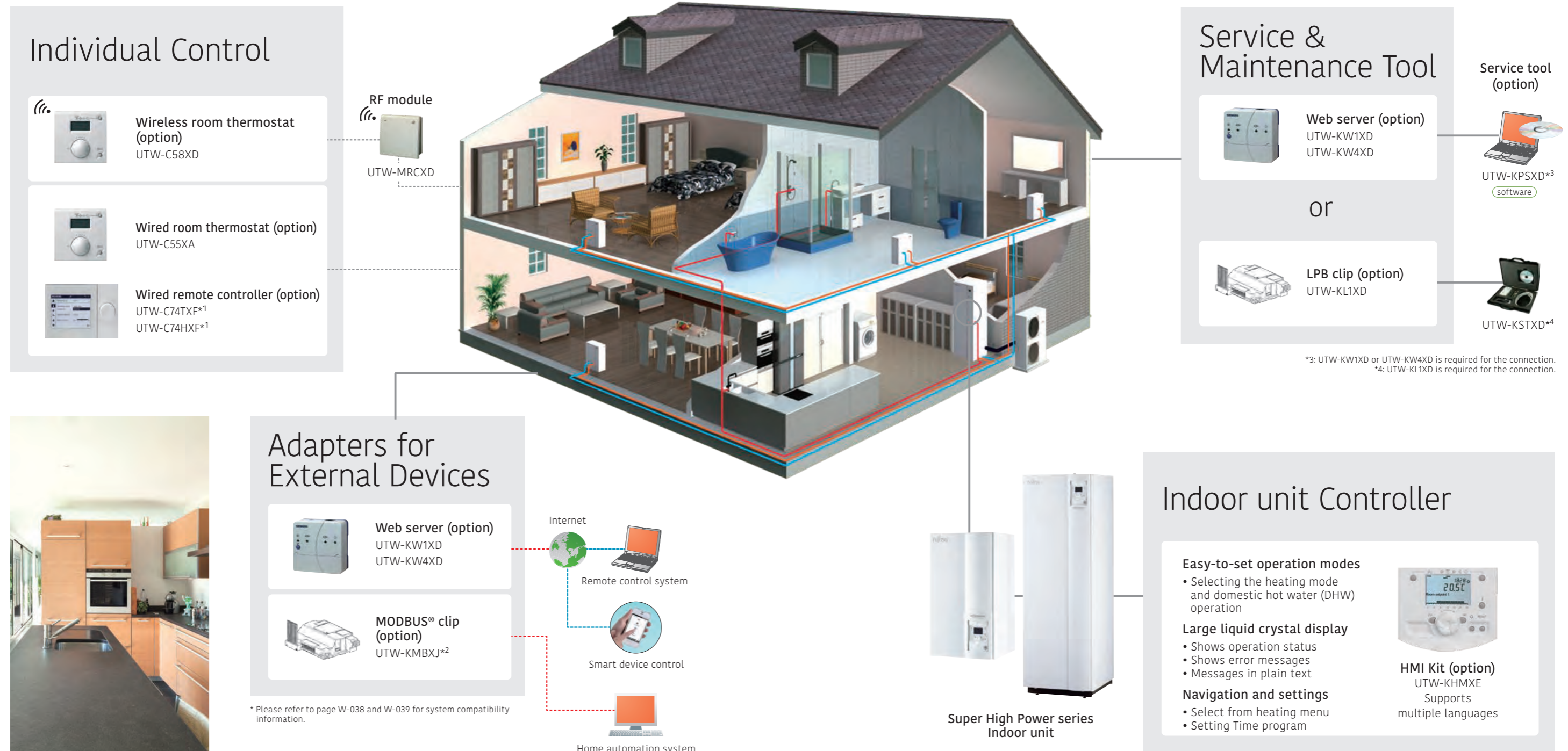

Type-**B**

Optional Parts Overview

Various optional parts are available to use ATW according to needs and environments.

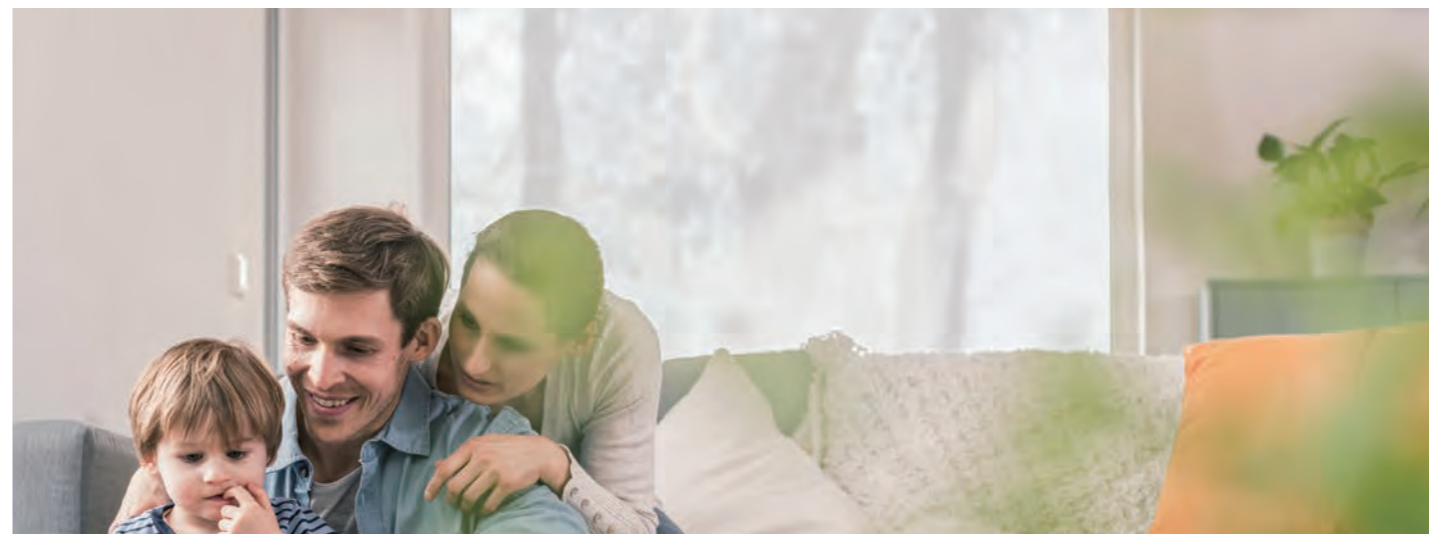

for Locally units



Second Circuit Kit

It can supply hot water at different temperatures to each two types of heating equipment, such as radiators and underfloor heating.

UTW-KZSXE*1



UTW-KZDXE*1



UTW-KZSXJ



UTW-KZDXJ

Boiler Connection Kit

It can build hybrid systems using both boilers and heat pumps. Boiler and heat pumps are switched according to outside air temperature.



UTW-KBSXD



UTW-KBDXD



UTW-KBSXJ

*1: The UTW-KREXD (Regulation Extension Kit) is not included but is required for connection.



for Indoor unit



Circulating Pump

UTW-PHFYG

The high-output pump for replacement of the standard pump in the hydraulic unit. It can be used in properties with longer and more complex water pipe.

Cascade Master/Slave Kit

Up to 3 indoor units can be connected for large-capacity use. It is need to install a primary kit in one unit and a secondary kit in one or two other units.



Cascade Master Kit (incl. LPB clip)



Cascade Slave Kit (incl. LPB clip)

Cooling Kit

Required when using ATW also for cooling operation. It is used to prevent condensation occurring in the indoor unit.



UTW-KCLXD



UTW-KCLXL

for Outdoor unit



Drain Pan

UTW-KDPXB

It is used to collect and drain condensation water generated by outdoor unit.



External Connection Kit

UTY-XWZXZ2 / UTY-XWZXZ3

The signal input (low noise mode, peak cut) and signal output (compressor operation, base pan heater control) for outdoor unit are possible externally.

for DHW



DHW Kit

UTW-KDWXD (External)

Required to connect locally purchased DHW tanks to Air to Water.



DHW Tank

200 Liters: UTW-T20AXH / UTW-T20BXH

300 Liters: UTW-T30AXH / UTW-T30BXH

The BXH series is a more efficient tank than the AXH series.



UTW-KDEXE



UTW-KDEXL

DHW Expansion Kit

The expansion vessel(18L) for connection to DHW water pipe.



Type-B Optional Parts List

Product Name	Model Name	Split Type										Split DHW Integrated Type												
		Super High Power			High Power				R32 Comfort			Super High Power			High Power				R32 Comfort					
		1Ø	3Ø		1Ø	1Ø	3Ø	1Ø	3Ø	1Ø		1Ø	3Ø		1Ø	1Ø	3Ø	1Ø	3Ø	1Ø				
		16	15	17	11	14	11	14	16	5	6	8	10	16	15	17	11	14	11	14	16	5	6	8
Second Circuit Kit	UTW-KZSXE	-	-	-	•*	•*	•*	•*	•*	•*	•*	•*	-	-	-	-	-	-	-	-	-	-	-	-
	UTW-KZDXE	-	-	-	-	-	-	-	-	-	-	-	-	-	•*	•*	•*	•*	•*	•*	•*	•*	•*	•*
	UTW-KZSXJ	•	•	•	-	-	-	-	-	-	-	-	-	-	-	-	-	-	-	-	-	-	-	-
	UTW-KZDXJ	-	-	-	-	-	-	-	-	-	-	-	•	•	•	-	-	-	-	-	-	-	-	-
Boiler Connection Kit	UTW-KBSXD	-	-	-	•	•	•	•	•	•	•	•	-	-	-	-	-	-	-	-	-	-	-	-
	UTW-KBDXD	-	-	-	-	-	-	-	-	-	-	-	-	-	•	•	•	•	•	•	•	•	•	•
	UTW-KBSXJ	•	•	•	-	-	-	-	-	-	-	-	•	•	•	-	-	-	-	-	-	-	-	-
Balancing vessel	UTW-TEVXA	•	•	•	•	•	•	•	•	•	•	•	•	•	•	•	•	•	•	•	•	•	•	•
DHW Kit	UTW-KDWXD (External)	•	•	•	•	•	•	•	•	•	•	•	•	•	•	•	•	•	•	•	•	•	•	•
DHW tank	200 Liters 300 Liters UTW-T20AXH UTW-T30AXH	•	•	•	•	•	•	•	•	•	•	•	•	•	•	•	•	•	•	•	•	•	•	•
	200 Liters 300 Liters UTW-T20BXH UTW-T30BXH	•	•	•	•	•	•	•	•	•	•	•	•	•	•	•	•	•	•	•	•	•	•	•
DHW Expansion Kit	UTW-KDEXE	-	-	-	-	-	-	-	-	-	-	-	•	•	•	•	•	•	•	•	-	-	-	-
	UTW-KDEXL	-	-	-	-	-	-	-	-	-	-	-	-	-	-	-	-	-	-	-	•	•	•	•
Circulating pump	UTW-PHFXG	•	•	•	•	•	•	•	•	•	•	•	•	•	•	•	•	•	•	•	-	-	-	-
Cooling Kit	UTW-KCLXD	•	•	•	•	•	•	•	•	•	•	•	•	•	•	•	•	•	•	•	-	-	-	-
	UTW-KCLXL	-	-	-	-	-	-	-	-	-	-	-	-	-	-	-	-	-	-	-	•	•	•	•
Regulation Extension Kit	UTW-KREXD	•	•	•	•	•	•	•	•	•	•	•	•	•	•	•	•	•	•	•	•	•	•	•
Drain pan	UTW-KDPXB	-	-	-	-	-	-	-	-	-	-	-	-	-	-	-	-	-	-	-	•	•	•	-
Cascade Master Kit (incl. LPB clip)	UTW-KCMXE	-	-	-	•	•	•	•	•	-	-	-	-	-	-	-	-	-	-	-	-	-	-	-
Cascade Slave Kit (incl. LPB clip)	UTW-KCSXE	-	-	-	•	•	•	•	•	-	-	-	-	-	-	-	-	-	-	-	-	-	-	-

Product Name	Model Name	Split Type										Split DHW Integrated Type												
		Super High Power			High Power				R32 Comfort			Super High Power			High Power				R32 Comfort					
		1Ø	3Ø		1Ø	1Ø	3Ø	1Ø	3Ø	1Ø		1Ø	3Ø		1Ø	1Ø	3Ø	1Ø	3Ø	1Ø				
		16	15	17	11	14	11	14	16	5	6	8	10	16	15	17	11	14	11	14	16	5	6	8
HMI Kit	UTW-KHMXE	•*	•*	•*	•*	•*	•*	•*	•*	•*	•*	•*	•*	•*	•*	•*	•*	•*	•*	•*	•*	•*	•*	•*
Remote controller	Wired UTW-C74TXF	•*	•*	•*	•*	•*	•*	•*	•*	•*	•*	•*	•*	•*	•*	•*	•*	•*	•*	•*	•*	•*	•*	•*
	UTW-C74HXF	•*	•*	•*	•*	•*	•*	•*	•*	•*	•*	•*	•*	•*	•*	•*	•*	•*	•*	•*	•*	•*	•*	•*
Room thermostat	Wired UTW-C55XA	•	•	•	•	•	•	•	•	•	•	•	•	•	•	•	•	•	•	•	•	•	•	•
	Wireless UTW-C58XD	•*	•*	•*	•*	•*	•*	•*	•*	•*	•*	•*	•*	•*	•*	•*	•*	•*	•*	•*	•*	•*	•*	•*
Outdoor sensor transmitter	UTW-MOSXD	•*	•*	•*	•*	•*	•*	•*	•*	•*	•*	•*	•*	•*	•*	•*	•*	•*	•*	•*	•*	•*	•*	•*
RF modules for BSB-Port	UTW-MRCXD	•	•	•	•	•	•	•	•	•	•	•	•	•	•	•	•	•	•	•	•	•	•	•
Web server	UTW-KW1XD	•*	•*	•*	•*	•*	•*	•*	•*	•*	•*	•*	•*	•*	•*	•*	•*	•*	•*	•*	•*	•*	•*	•*
	UTW-KW4XD	-	-	-	•*	•*	•*	•*	•*	-	-	-	-	-	-	-	-	-	-	-	-	-	-	-
LPB clip	UTW-KL1XD	•	•	•	•	•	•	•	•	•	•	•	•	•	•	•	•	•	•	•	•	•	•	•
MODBUS® clip	UTW-KMBXJ	-	-	-	•*	•*	•*	•*	•*	-	-	-	-	-	-	-	-	-	-	-	•*	•*	•*	•*
Service tool (incl. OCI700 Adapter)	UTW-KSTXD	•*	•*	•*	•*	•*	•*	•*	•*	•*	•*	•*	•*	•*	•*	•*	•*	•*	•*	•*	•*	•*	•*	•*
Service tool software	UTW-KPSXD	•*	•*	•*	•*	•*	•*	•*	•*	•*	•*	•*	•*	•*	•*	•*	•*	•*	•*	•*	•*	•*	•*	•*
External Connect Kit	UTY-XWZXZ2	-	-	-	•	•	•	•	•	-	-	-	-	-	-	-	-	-	-	-	•	•	•	•
	UTY-XWZXZ3	•	•	•	-	-	-	-	-	-	-	-	-	-	•	•	•	•	•	•	-	-	-	•
Electrical backup heater relay	UTW-KBHXL	-	-	-	-	-	-	-	•	•	•	•	-	-	-	-	-	-	-	-	•	•	•	•

*1: The UTW-KREXD (Regulation Extension Kit) is not included but is required for connection. •: Available -: Not Available
 *2: Split DHW integrated type supplies DHW without the DHW Kit and DHW tank.
 *3: Includes 21 languages with no need to prepare an RC for Eastern Europe separately.
 C74TXF has a built-in room temperature sensor. C74HXF has a built-in room temperature and humidity sensor.
 *4: UTW-MRCXD (RF modules) is required for the connection.
 *5: The connection of UTW-KW4XD for simultaneous control of multiple ATW units is only possible for cascade systems.
 *6: Additional Spare parts 9708302034 (Analogue interface PCB) and 109696 (connection wire) are required.
 *7: UTW-KL1XD (LPB clip) is required for the connection.
 *8: UTW-KW1XD or UTW-KW4XD (Web server) is required for the connection.