

Light Commercial & Residential SPLIT & MULTI-SPLIT

Energy saving design to provide a comfortable indoor environment while being environment-friendly.

These are air conditioners that are both user-friendly and environment-friendly. General air conditioners cater to a wide range of needs, from living rooms, bedrooms, stores, small offices, through to hotels.

SPLIT

- Refrigerant R32 Models
 - Wall-Mounted
 - Cassette
 - Duct
 - Floor
 - Ceiling
- Refrigerant R410A Models
 - Duct

MULTI-SPLIT

- Refrigerant R32 Models
 - 2-unit to 5-unit Multi-Split
 - Simultaneous Multi-Split Twin/Triple
 - Simultaneous Multi-Split Twin/Triple/Double Twin
- Refrigerant R410A Models
 - 6-unit Multi-Split
 - Simultaneous Multi-Split Twin/Triple/Double Twin



SPLIT & MULTI-SPLIT

Light Commercial &
Residential

Light Commercial & Residential SPLIT

- S-004 Split Overview
- S-006 Indoor Units Lineup
- S-010 Features
- S-015 Features Explanation
- S-060 Wall-mounted Specifications
- S-063 ECO Series Lineup Specifications
- S-068 Feature Summary



Refrigerant R32 Models

Wall-Mounted - Built in WLAN adapter model

- S-016 Designer Range
 - High Spec & Design
 - Cool Beauty Design
- S-020 Standard Range - High-Efficiency & Comfort
- S-022 ECO Range - Compact Size

Wall-Mounted

- S-024 Standard Range
 - High-Efficiency & Large Room
- S-028 ECO Range
 - Compact Size
 - Comfort for Large Room
 - Cooling-enhanced type

Cassette

- S-034 Compact 4-way Flow Range - Compact Size
- S-036 Circular Flow Range - Comfort for Large Room

Duct

- S-038 Slim Duct - Slim Design
- S-040 Medium Static Pressure Duct
 - High-Efficiency & Comfort
 - Compact Size
 - Standard
- S-050 High Static Pressure Duct

Floor, Ceiling

- S-056 Floor - Compact Size
- S-058 Ceiling



Refrigerant R410A Models

Duct

- S-052 High Static Pressure Duct
- S-054 Big Duct

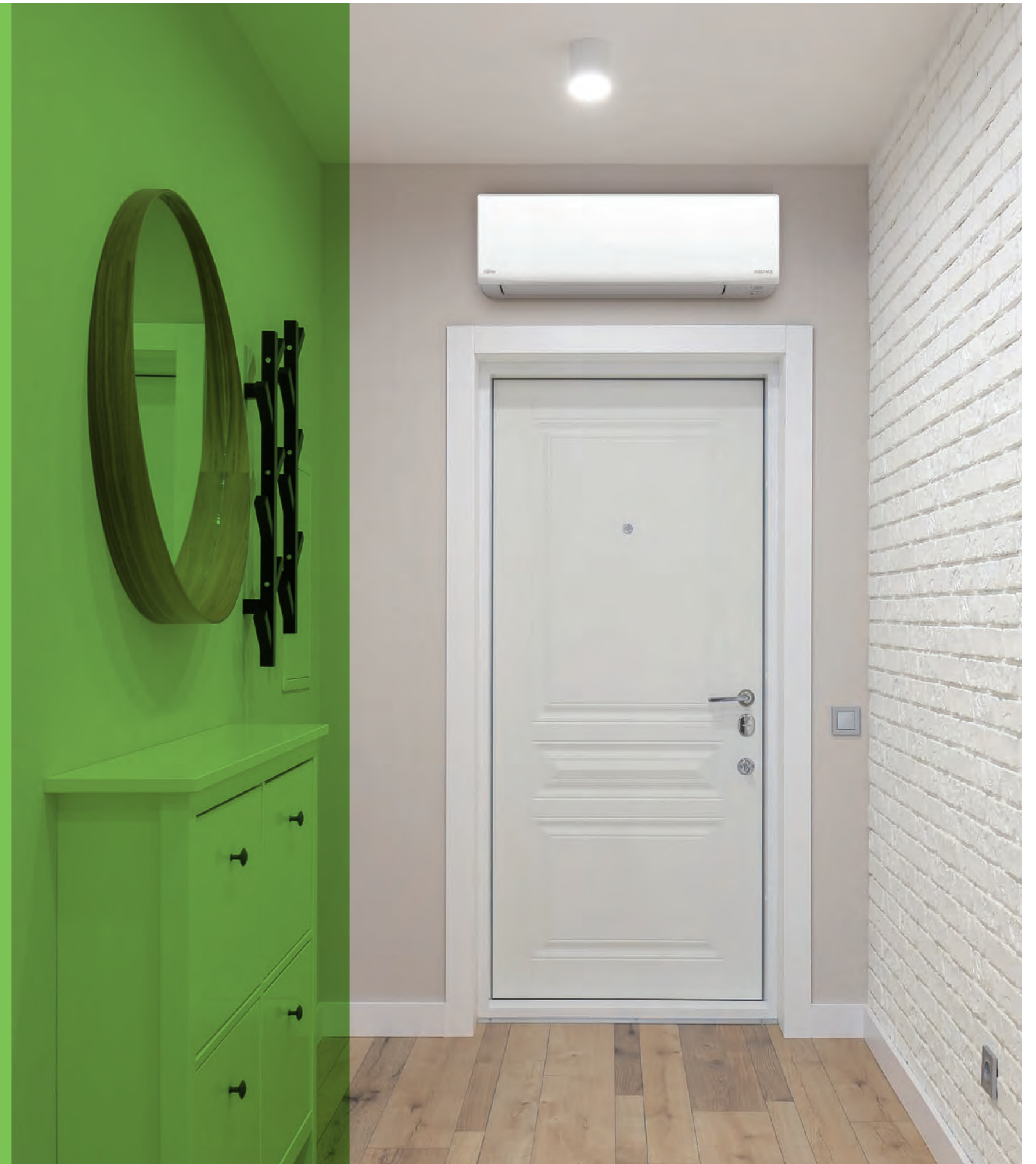

Split Overview

General provides its customers with 5 types and 86 models of air conditioning systems perfect for various customer applications and layouts.



Existing Pipes can be Reused If They Meet Our Guidelines

Please consult with our regional sales subsidiaries for details.

Cautions When Reusing The Existing Pipes

- The thickness of the pipes must be 0.8 mm or thicker in accordance with the pipe diameter.
- Use flares that have been reworked to be compatible with the new refrigerant, and are compliant with ISO 14903.
- Select suitable wire in accordance with the installation manual of the new air conditioning unit.
- When pump-down is not possible or when the inner pipe walls are dirty, make sure to clean the pipes before connecting new ones.
- When using different diameters pipes from the standard sizes,
 - The performance may not reach the published specification value.
 - Dedicated flare nuts compliant with ISO 14903 should be procured locally.
 - Restrictions apply to pipe lengths, refrigerant volumes, and room sizes.



Wall-Mounted

Simple and easy to install, all models, are expertly designed to control airflow and save energy. The design, with its flat and simple appeal, perfectly matches room interiors. All models use the environmentally friendly refrigerant R32.



Duct

The main unit is hidden in the wall, making the room look neat and tidy. The lineup also includes slim duct models that can be installed in narrow spaces such as between beams and under ceilings. Large models, suitable for air conditioning vast spaces, allow multiple outlets to be installed in just one unit, and are perfect for atypical room layouts.



Cassette

The Cassette type, which blends in perfectly with the interior design, blows air in all four directions to create an even air-conditioning for the entire space. We have a variety of series including Compact models with a uniquely designed panel to match grid ceilings, and Circular Flow models that send airflow in a 360° direction.



Floor

The compact and slim design makes this model suitable for installation in commercial as well as residential buildings. This model is also recommended as a heating device because it delivers a warm airflow from both the top and bottom outlets.



Ceiling

As with the wall-mounted unit, ceiling installation is very easy, and the unit's thin structure with a height of just 240 mm allows neat installation. The powerful airflow that can reach far away from the wide outlet is perfect for large meeting rooms, audiovisual rooms, and other rectangular spaces with a lot of depth.

Indoor Units Lineup



GENERAL HVAC Solutions Euro GmbH participates in the ECP program for AC. Check ongoing validity of certificate: www.eurovent-certification.com

Type	Range	Refrigerant	Model	Class														
				7	9	12	14	18	22	24	30	36	45	54	60	72	90	
Wall-Mounted <small>Built in WLAN adapter model</small>	Designer Range Minimal Elegance Design	Cooling & Heating	KJ Series	ASEH07KJCAL ASEH07KJCALB	ASEH09KJCAL ASEH09KJCALB	ASEH12KJCAL ASEH12KJCALB	ASEH14KJCAL ASEH14KJCALB											
	Standard Range High-Efficiency & Comfort	Cooling & Heating	KM Series	ASEH07KMCG ASEH07KMCG-B	ASEH09KMCG ASEH09KMCG-B	ASEH12KMCG ASEH12KMCG-B	ASEH14KMCG ASEH14KMCG-B											
	Standard Range High-Efficiency & Large Rooms	Cooling & Heating	KM Series					ASEH18KMTGL		ASEH24KMTGL								
	ECO Range Compact Size	Cooling & Heating	KN Series	ASEH07KNCA	ASEH09KNCA	ASEH12KNCA												
	ECO Range Cooling-enhanced	Cooling & Heating	KL Series	ASEH07KLTBL	ASEH09KLTBL	ASEH12KLTBL												
	ECO Range Comfort for Large Rooms	Cooling & Heating	KL Series					ASEH18KLCBL		ASEH24KLCBL								
Wall-Mounted	Standard Range High-Efficiency & Large Rooms	Cooling & Heating	KM Series									ASEH30KMTB	ASEH36KMTB					

Indoor Units Lineup



GENERAL HVAC Solutions Euro GmbH participates in the ECP program for AC. Check ongoing validity of certificate: www.eurovent-certification.com

Type	Range	Refrigerant	Model	Class														
				7	9	12	14	18	22	24	30	36	45	54	60	72	90	
Cassette	Compact 4-way Flow Range Fits grid ceiling	R32 Cooling & Heating			AUXG09KVLA	AUXG12KVLA	AUXG14KVLA	AUXG18KVLA	AUXG22KVLA	AUXG24KVLA								
	Circular Flow Range Comfort for Large Rooms	R32 Cooling & Heating	 18/22/24 30/36/45/54					AUXG18KRLB	AUXG22KRLB	AUXG24KRLB	AUXG30KRLB	AUXG36KRLB	AUXG45KRLB	AUXG54KRLB				
Duct	Low Static Pressure Range Slim Type ESP up to 90 Pa Ultra-slim 198 mm with built-in drain pump.	R32 Cooling & Heating	 09/12/14 18		ARXG09KLLAP	ARXG12KLLAP	ARXG14KLLAP	ARXG18KLLAP										
	Medium Static Pressure Range	High-Efficiency & Comfort ESP up to 150 Pa The slimmest medium static pressure duct – only 240 mm with built-in drain pump.	R32 Cooling & Heating	 12/14/18 22/24 30/36/45/54			ARXH12KMTAP	ARXH14KMTAP	ARXH18KMTAP	ARXH22KMTAP	ARXH24KMTAP	ARXH30KMTAP	ARXH36KMTAP	ARXH45KMTAP	ARXH54KMTAP			
		Standard ESP up to 150 Pa	R32 Cooling & Heating							ARXG22KMLB	ARXG24KMLA	ARXG30KMLA	ARXG36KMLA	ARXG45KMLA				
	High Static Pressure Duct	Compact Size ESP up to 200 Pa Compact 300 mm design with integrated drain pump for easy installation.	R32 Cooling & Heating	 12/14 18/22/24/30 36/45/54			ARXG12KHTAP	ARXG14KHTAP	ARXG18KHTAP	ARXG22KHTAP	ARXG24KHTAP	ARXG30KHTAP	ARXG36KHTAP	ARXG45KHTAP	ARXG54KHTAP			
		Standard ESP up to 250 Pa	R32 Cooling & Heating											ARXG45KHTB	ARXG54KHTB			
		High-Efficiency & Comfort ESP up to 260 Pa	R32 Cooling & Heating	NEW													ARXH60KHTA	
			R410A Cooling & Heating														ARYG60LHTA	
High-Efficiency ESP up to 200 Pa		R32 Cooling & Heating	NEW													ARXH72KHTA	ARXH90KHTA	
Standard ESP up to 200 Pa* (*72:150 Pa)	R410A Cooling & Heating														ARYG72LHTA	ARYG90LHTA		
Floor Compact & Comfort		R32 Cooling & Heating			AGEG09KVCA	AGEG12KVCA	AGEG14KVCA											
Ceiling		R32 Cooling & Heating	 18/22 24/30 36/45/54						ABEG18KRTA	ABEG22KRTA	ABEG24KRTA	ABEG30KRTA	ABEG36KRTA	ABEG45KRTA	ABEG54KRTA			

Features

High-Efficiency

ALL DC All DC Inverter Technology



DC Twin-Rotary Compressor

A high-efficiency 2-cylinder rotary compressor with a DC inverter optimizes the internal structure of the compressor to achieve higher energy efficiency compared to similar compressors.

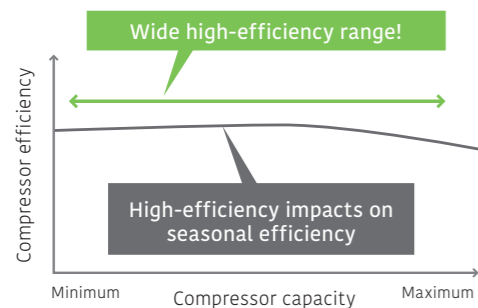

DC Fan Motor

The DC fan motor produces high power, a wide operating range, and high-efficiency.

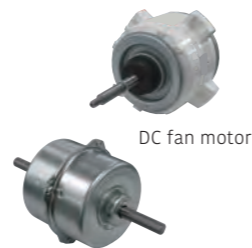

Sine-Wave DC Inverter Control

High-efficiency operation is realized by using sine-wave DC inverter control.

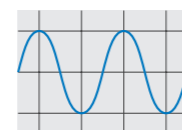

High Energy Saving

Save+Stop Occupancy Sensor Control

The Occupancy sensor monitors the movements of people in a room and operates the air conditioner at a lower capacity when people leave the room. When people come back to the room, it automatically returns to the previous operating mode.

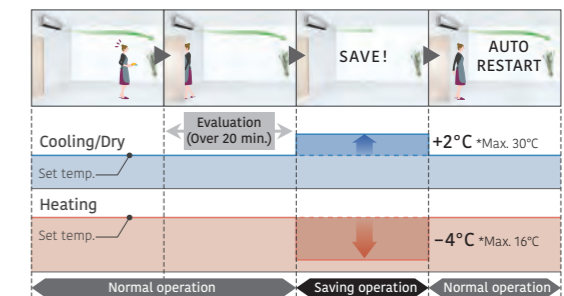

Economy Economy Operation

Limits maximum operation, reducing the power consumption, and thereby suppressing the maximum load.

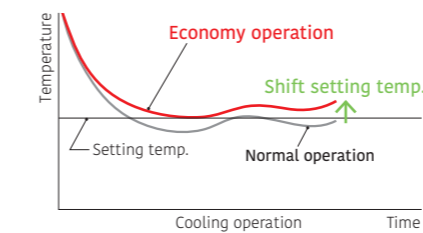

Set Temp. Setting Temperature Range Limitation

The minimum and maximum temperature range can be set giving further energy savings while considering the comfort of the occupants.

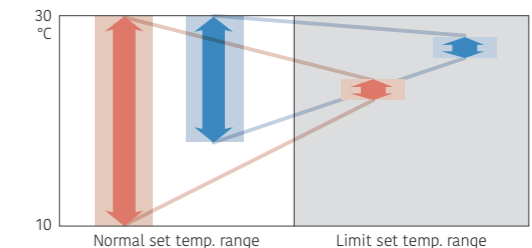

Return Set Temperature Auto Return

- The set temperature automatically returns to the previously set temperature.
- The time range in which the set temperature can be changed is from 10 to 120 minutes.

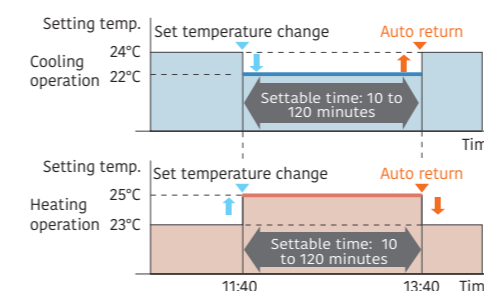

Auto OFF Auto-Off Timer

- The indoor unit is automatically turned off when it reaches a preset operating time frame.
- The time frame of the Auto-off timer can be flexibly scheduled.
- Auto-off times can be set from 30 to 240 minutes.

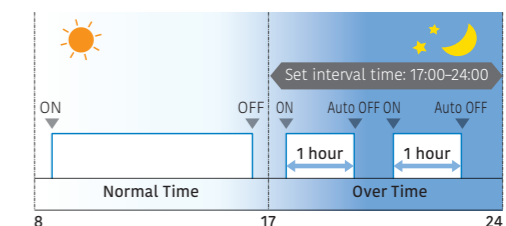

Heat Exchanger for Wall-Mounted

High-density multipath heat exchanger

Thinner and denser heat exchangers and multipath efficiency technology have substantially improved heat exchange performance.

High-performance sub-cool heat exchanger

A counter-type bypass circuit has been incorporated to achieve a higher performance. (Large multi-split type, VRF)

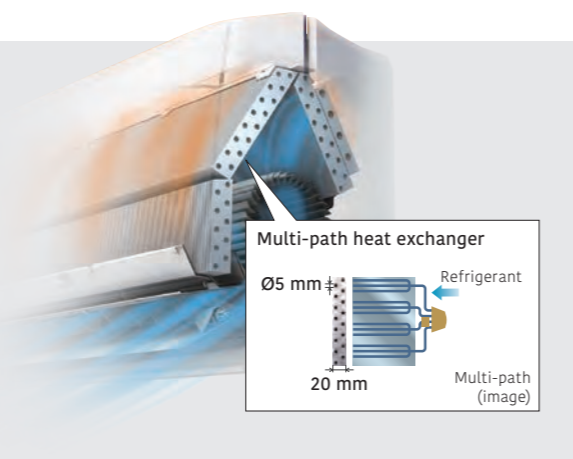

More Comfort



Powerful Operation

Maximum airflow and maximum compressor speed are maintained for the period necessary to reach the set temperature quickly.

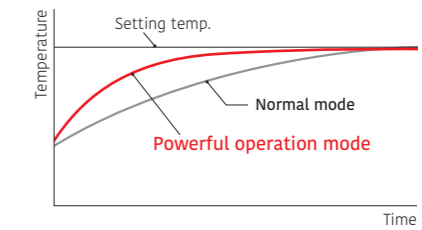

10°C Heat

After a person has left the room, the system switches to minimum heating operation to maintain the room temperature. (Maintained at 10°C)

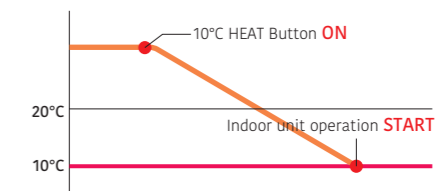

Wireless LAN Control

Users can control their air conditioners from anywhere with their mobile devices while out or on the move.

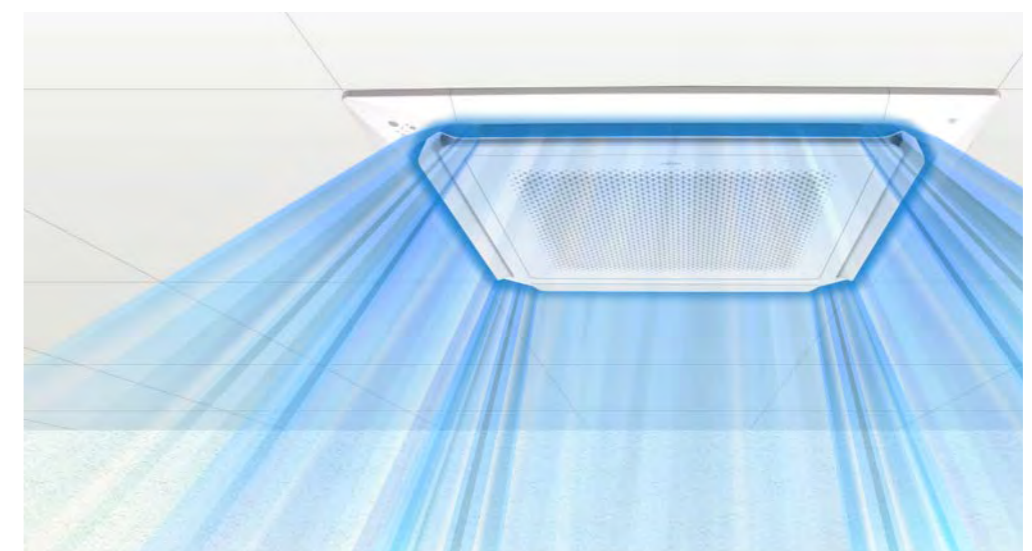
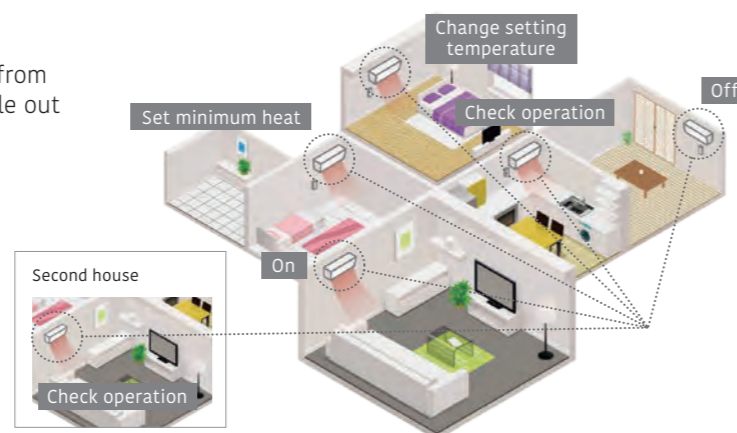

Individual Airflow Direction Control

Circular airflow to achieve uniform air conditioning without temperature unevenness in workspaces



Quiet and Comfort Control



Low Noise Technology

Outdoor Unit Fan

Outdoor unit fan design with a small separation vortex, minimized air volume by fan control, and top-class low noise

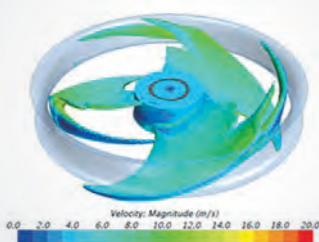

Air Stabilizer in Duct

Low-noise duct structure with a built-in air stabilizer

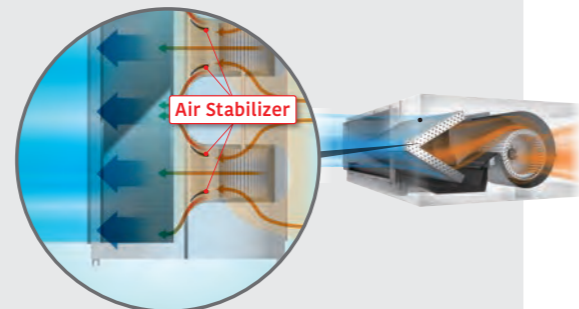

Outdoor Unit Low Noise Operation

Users can choose low noise levels, depending on the installation environment. Operation time can be set by timer.

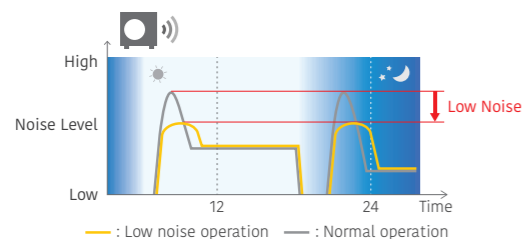

*During Outdoor unit low noise operation, the maximum capacity is reduced, so it may take longer for the room to warm up.
*Even if Outdoor unit low noise operation is set, the operating noise may not decrease if the room temperature is close to the set temperature.

Auto Changeover

In an auto setting, the system automatically switches between cooling and heating modes according to the set temperature and room temperature.

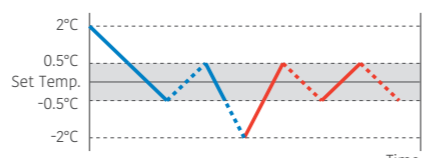

— Cooling operation ···· Cooling fan operation
— Heating operation ···· Heating fan operation

Fresh Air Intake for Cassette, Duct, Ceiling

Fresh air is taken in by a fan connected to an external control unit.



Fresh Air Intake Kit

Feature Explanation

Energy-Saving Features

- Save Occupancy Sensor**
The Occupancy sensor detects the movement of people in the room and determines whether to switch to energy saving operation.
- Occupancy Sensor Control**
The Occupancy sensor (option) detects movement of people in the room and decides whether to save energy or stop the unit.
- Economy Operation**
The thermostat setting is adjusted automatically according to the room temperature to avoid unnecessary cooling or heating.
- Setting Temperature Range Limitation**
Sets the minimum and maximum limits on room temperature to establish the right balance between energy saving and a comfortable environment.
- Set Temperature Auto Return**
The setting temperature automatically returns to the previously set temperature.

Features for Comfort

- Powerful Operation**
Operation at maximum air flow and compressor speed, that quickly makes the room comfortable.
- 10°C Heat**
The room temperature can be set to go no lower than 10°C, thus ensuring that the room does not get too cold when not occupied.
- Outdoor Unit Low Noise Operation**
The noise level of the outdoor unit can be selected.
- Auto Changeover**
The unit automatically switches between heating and cooling modes based on the temperature setting and the room temperature.
- UP/DOWN Swing Louver**
The vertical louver automatically swings up and down.
- Double Swing Automatic**
Complex swing action of the louver enables automatic swing in both the left/right and up/down directions.
- Automatic Fan Speed**
A micro-computer automatically adjusts the airflow to follow the changes in room temperature.
- Auto Restart**
In the event of a temporary power failure, the air conditioner will automatically restart in the same operating mode as before, once the power supply is restored.
- Connectable Fresh Air Duct**
Outside air can be introduced by attaching a locally purchased duct to the fresh air knockout and an optional part.
- Fresh Air Intake**
Fresh air can be taken in by a fan connected to an external control unit.
- Connectable Distributing Duct**
Locally purchased branch ducts can be attached to the systems to distribute the airflow.
- Individual Airflow Direction Control**
Each louver of a 4-Way Cassette type can be controlled individually to provide comfortable airflow.

Convenience Features

- Auto-Off Timer**
Automatically stops operation when a fixed time has elapsed from the start of operation.
- Sleep Timer**
A micro-computer gradually changes the room temperature automatically to promote a comfortable night's sleep.
- Program Timer**
This digital timer allows selection of one of four options: ON, OFF, ON » OFF, or OFF » ON.
- Weekly Timer**
Different ON-OFF times can be set for each day.
- Weekly & Temperature Setback Timer**
Weekly & Temperature setback timer can set the temperature for 2-time spans and for each day of the week.
- Filter Sign**
Indicates the filter cleaning period by blinking.
- External Error Output**
- External ON/OFF Input**
- Wireless LAN Control**
The optional WLAN adapter enables the air conditioner to be operated by smartphone or tablet PC from outside the home.
- Multi System Control**
Operation using "Lead Lag Operation", "Back up operation", "Lag Operation" is possible. (Page C-011)
- Special Cooling**
Special Cooling" is a function that supports the operation of "Multi System Control".
- Individual auto**
To accommodate Europe's temperature differences between day and night, the system has a function that allows users to set separate temperatures for cooling and heating and automatically switches between them.

Clean Features

- Ion Deodorization Filter**
The filter deodorizes by powerfully decomposing absorbed odors using the oxidizing and reducing effects of ions generated by an ultra-fine-particle ceramic.
- Apple-Catechin Filter**
The Apple-catechin filter uses static electricity to clean fine particles and dust from the air.
- Long-Life Filter**
- Washable Panel**
Since the front panel is easy to remove, maintenance is also easy.
- Silver Ion Filter**
The Silver ion filter helps to keep indoor air free from viruses, bacteria and molds.
- Heat Clean**
Heats the heat exchanger (aluminum fins) inside the air conditioner to over 55°C, along with any accumulated water, to quickly and effectively clean it.

Installation / Support

- Automatic Airflow Adjustment**
Automatically detects required airflow in each application case and adjusts the volume.
- Drain Pump As Standard**
- Blue Fin**
- Refrigerant Cycle Monitor**
The values of each sensor and actuator can be displayed, and the status of the refrigeration cycle can be checked.

ALL DC models

SPLIT

NEW

KJ Series

Wall-Mounted

Built-in WLAN adapter model
Designer Range
Minimal Elegance Design



Minimal Elegance

The clean lines and strong, elegant curves give it an elegant look. Its compact width allows it to be installed in narrow spaces such as above doors.

High Energy Saving

High-efficiency has been achieved by the lambda-shaped heat exchanger, large cross-flow fan, and the R32 refrigerant.

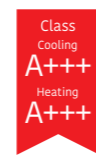

SEER **9.60*** SCOP **5.10***

*07 model

*07 model

*07 model

Heat Clean

Heats the heat exchanger (aluminum fins) inside the air conditioner to over 55°C along with any accumulated water to quickly and effectively clean it. It is also effective against mold that has adhered to the unit.*

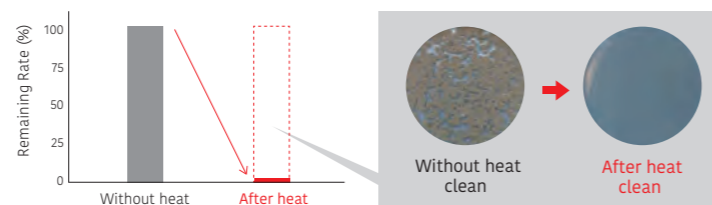

Test organization name: Kitasato Research Center for Environmental Science
Report No.: KRCEs - Bio. Test Report No. 2025_1003. Mold control rate: 99% or higher after heat clean operation.
*Tested on actual equipment. (12 model) Results may vary based on usage, seasonal, and environmental variables.

INDIVIDUAL AUTO

To accommodate Europe's temperature differences between day and night, the system has a function that allows users to set separate temperatures for cooling and heating and automatically switches between them.

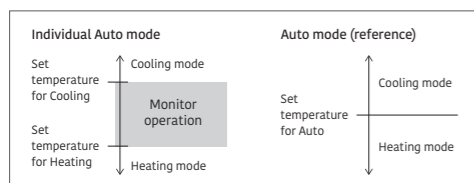

Equipped with Occupancy Sensor

The Occupancy sensor monitors the movements of people in a room and operates the air conditioner at a lower capacity when people leave the room. When people come back to the room, it automatically returns to the previous operating mode.

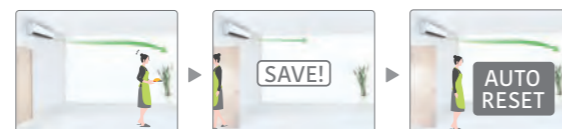

Model: ASEH07KJCAL / ASEH09KJCAL / ASEH12KJCAL / ASEH14KJCAL
ASEH07KJCALB / ASEH09KJCALB / ASEH12KJCALB / ASEH14KJCALB



WLAN adapter (Built-in)

Wireless RC



Specifications

Model name	Indoor unit		ASEH07KJCAL ASEH07KJCALB	ASEH09KJCAL ASEH09KJCALB	ASEH12KJCAL ASEH12KJCALB	ASEH14KJCAL ASEH14KJCALB
	Outdoor unit		AOEH07KJCA	AOEH09KJCA	AOEH12KJCA	AOEH14KJCA
Power Source			Single phase, 230V, ~50Hz			
Capacity	Cooling	Rated	2.0	2.5	3.4	4.2
		Min-Max	0.9-3.0	0.9-3.2	0.9-3.9	0.9-4.3
	Heating	Rated	2.5	2.8	4.0	5.2
		Min-Max	0.9-3.6	0.9-4.5	0.9-5.4	0.9-5.9
Input Power	Cooling/Heating	kW	0.400 / 0.500	0.550 / 0.600	0.870 / 0.950	1.260 / 1.400
EER	Cooling	W/W	5.00	4.55	3.91	3.33
COP	Heating	W/W	5.00	4.67	4.21	3.71
Pdesign	Cooling/Heating(-10°C)	kW	2.0 / 2.3	2.5 / 2.4	3.4 / 2.5	4.2 / 4.0
SEER	Cooling	W/W	9.60	9.20	8.70	7.90
SCOP	Heating (Average)	W/W	5.10	5.10	5.10	4.60
Energy Efficiency Class	Cooling		A+++	A+++	A+++	A++
	Heating (Average)		A+++	A+++	A+++	A++
Max. Operating Current	Cooling/Heating	A	6.5 / 9.0	6.5 / 9.0	6.5 / 9.0	7.0 / 9.0
Annual Energy Consumption	Cooling	kWh/a	73	95	137	186
	Heating		631	658	685	1,216
Moisture Removal		l/h	1.0	1.0	1.5	1.6
Sound Pressure Level	Indoor (Cooling)	H/M/L/Q	36 / 31 / 24 / 19	38 / 31 / 24 / 19	41 / 34 / 25 / 20	45 / 35 / 25 / 20
	Indoor (Heating)	H/M/L/Q	38 / 31 / 24 / 20	38 / 31 / 24 / 20	41 / 34 / 25 / 21	44 / 35 / 25 / 21
	Outdoor (Cooling/Heating)	High	42 / 42	44 / 44	47 / 47	47 / 52
	Indoor (Cooling/Heating)	High	51 / 52	52 / 52	56 / 56	59 / 59
Sound Power Level	Outdoor (Cooling/Heating)	High	55 / 54	56 / 55	58 / 59	59 / 63
	Indoor / Outdoor (Cooling)	High	540 / 1,390	580 / 1,480	630 / 1,690	720 / 1,690
Airflow Rate	Indoor / Outdoor (Heating)	High	580 / 1,350	580 / 1,420	630 / 1,690	720 / 1,860
Net Dimensions H x W x D	Indoor	mm	270 × 798 × 240	270 × 798 × 240	270 × 798 × 240	270 × 798 × 240
	Outdoor	mm	542 × 799 × 290	542 × 799 × 290	542 × 799 × 290	542 × 799 × 290
Weight	Indoor	kg	10	10	10.5	10.5
	Outdoor	kg	30	30	31	31
Connection Pipe Diameter (Liquid / Gas)		mm	6.35 / 9.52	6.35 / 9.52	6.35 / 9.52	6.35 / 9.52
Drain hose Diameter (I.D./O.D.)		mm	13.8 / 15 to 16.8	13.8 / 15 to 16.8	13.8 / 15 to 16.8	13.8 / 15 to 16.8
Max. Pipe Length (Pre-Charge)		m	20 (15)	20 (15)	20 (15)	20 (15)
Max. Height Difference			15	15	15	15
Operating Range	Cooling	°CDB	-10 to 50	-10 to 50	-10 to 50	-10 to 50
	Heating		-20 to 24	-20 to 24	-20 to 24	-20 to 24
Refrigerant	Type (Global Warming Potential)		R32 (675)	R32 (675)	R32 (675)	R32 (675)
	Charge	kg(CO2eq-T)	0.72 (0.486)	0.72 (0.486)	0.87 (0.587)	0.87 (0.587)

Optional parts

* For information on the compatibility of optional parts for Intesis products, please refer to the compatibility list at the end of the "Control system & Optional parts" chapter.

Wired Remote Controller (Design type): UTY-RVRY	KNX® converter: UTY-VKXS	Network Converter for single split (DC power supply type): UTY-VTGX
Compact wired remote controller: UTY-RCRYZ1	MODBUS® converter: UTY-VMSX	Network Converter for single split (AC power supply type): UTY-VTGXV
Wired remote controller (touch panel): UTY-RNRYZ6	Communication Kit: UTY-TWRXZ2	External input and output PCB ¹⁾ : UTY-XCSXZ2
Wired remote controller: UTY-RLRY	External Connect Kit: UTY-XWZX	External switch controller: UTY-TERX
Simple remote controller (without operation mode): UTY-RHRYZ1	UTY-XWZXZ5	
Simple remote controller: UTY-RSRYZ1	Silver Ion filter: UTR-FA16-5	

¹⁾ It is required when 2 or more external input and output ports are used.

Dimensions

(Unit: mm)

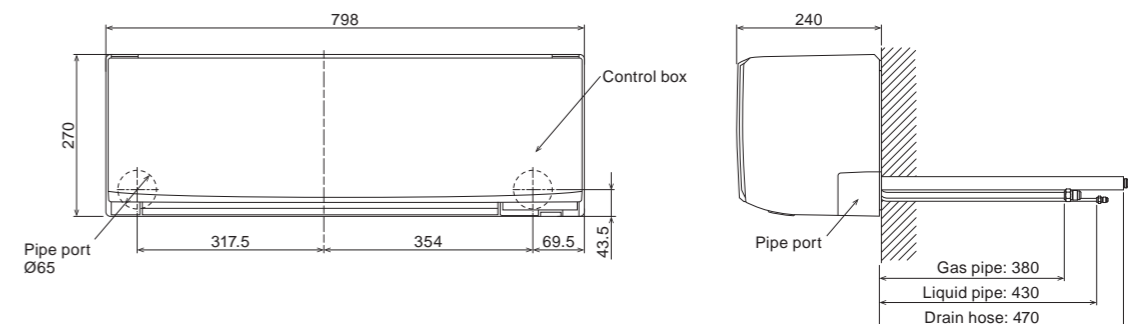

SPLIT

KM Series

Wall-Mounted

Built-in WLAN adapter model
Standard Range
High-Efficiency & Comfort



Slim & Stylish Square Design

The slim and stylish square design of this indoor unit is realized by using a high-density, multipath heat exchanger and a high-efficiency wind blower.



Warm & Gentle Color Option

Both white and soft black color are relatively gentle tones and no strong contrast, each color harmonize with the environment and create a warm atmosphere.

High Energy Saving

High-efficiency has been achieved by the lambda-shaped heat exchanger, large cross-flow fan, and the R32 refrigerant.

Class Cooling A++ Heating A++*

SEER 8.40* SCOP 4.60*

*07/09/12 models *07/09 models *07/09/12 models

Comfortable Airflow & Quiet Operation

The large louver and the air-blowing structure create a comfortable air flow that spreads all the way down to the user's feet with quiet operation.



Smart Device Control

A WLAN adapter is included as standard equipment. By installing the AIRSTAGE mobile app on your smart device, you can check and control the operating status of the air conditioner from anywhere indoors or outdoors.

* See page C-022 for details on smart device control.

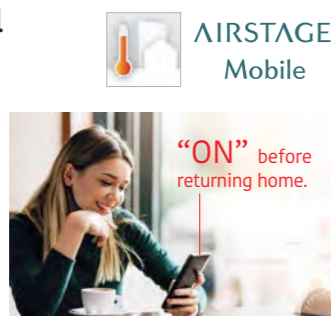

Refrigerant Cycle Monitor (Option)

Wired Remote Controller (Touch Panel) will support to display some sensor values for maintenance and service support.

*Wired remote controller (UTY-RNRYZ6 or UTY-RVRY) is required.

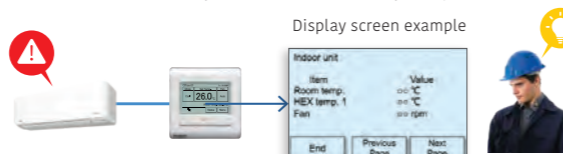

Model: ASEH07KMCG / ASEH09KMCG / ASEH12KMCG / ASEH14KMCG
ASEH07KMCG-B / ASEH09KMCG-B / ASEH12KMCG-B / ASEH14KMCG-B



WLAN adapter (Built-in)

Wireless RC



For ASEH07/09/12KMCG ASEH07/09/12KMCG-B



For ASEH14KMCG ASEH14KMCG-B

Specifications

Model name	Indoor unit		ASEH07KMCG ASEH07KMCG-B	ASEH09KMCG ASEH09KMCG-B	ASEH12KMCG ASEH12KMCG-B	ASEH14KMCG ASEH14KMCG-B
	Outdoor unit		AOEH07KMCG	AOEH09KMCG	AOEH12KMCG	AOEH14KMCG
Power Source			Single phase, ~230 V, 50 Hz			
Capacity	Cooling	Rated	2.0	2.5	3.4	4.2
		Min.-Max.	0.9-3.0	0.9-3.2	0.9-3.9	0.9-4.4
	Heating	Rated	2.5	2.8	4.0	5.4
		Min.-Max.	0.9-3.4	0.9-4.0	0.9-5.3	0.9-6.0
Input Power	Cooling/Heating	kW	0.450 / 0.555	0.650 / 0.620	0.960 / 1.020	1.220 / 1.410
EER	Cooling	W/W	4.43	3.85	3.54	3.44
COP	Heating	W/W	4.52	4.52	3.92	3.83
Pdesign	Cooling/Heating (-10°C)	kW	2.0 / 2.3	2.5 / 2.4	3.4 / 2.5	4.2 / 4.0
SEER	Cooling	W/W	8.40	8.40	7.70	7.10
SCOP	Heating (Average)	W/W	4.60	4.60	4.60	4.10
Energy Efficiency Class	Cooling		A++	A++	A++	A++
	Heating (Average)		A++	A++	A++	A+
Max. Operating Current	Cooling/Heating	A	6.5 / 9.0	6.5 / 9.0	6.5 / 9.0	6.5 / 9.0
Annual Energy Consumption	Cooling	kWh/a	83	104	155	207
	Heating	kWh/a	700	730	761	1,366
Moisture Removal		l/h	1.0	1.3	1.8	2.1
Sound Pressure Level	Indoor (Cooling)	H/M/L/Q	38 / 33 / 29 / 20	40 / 34 / 29 / 20	40 / 35 / 30 / 20	43 / 36 / 30 / 20
	Indoor (Heating)	H/M/L/Q	41 / 35 / 31 / 22	42 / 36 / 31 / 22	42 / 38 / 33 / 22	44 / 39 / 33 / 24
Sound Power Level	Outdoor (Cooling/Heating)	High	46 / 46	46 / 46	50 / 50	50 / 50
	Indoor (Cooling/Heating)	High	54 / 56	55 / 57	55 / 58	57 / 59
Airflow Rate	Indoor/Outdoor (Cooling)	High	650 / 1,650	700 / 1,650	700 / 1,700	770 / 1,680
	Indoor/Outdoor (Heating)	High	720 / 1,450	750 / 1,450	780 / 1,470	820 / 1,580
Net Dimensions	Indoor	mm	270 × 834 × 222	270 × 834 × 222	270 × 834 × 222	270 × 834 × 222
H x W x D	Outdoor	mm	541 × 663 × 290	541 × 663 × 290	541 × 663 × 290	542 × 799 × 290
Weight	Indoor	kg	10	10	10	10
	Outdoor	kg	22	22	24	31
Connection Pipe Diameter (Liquid/Gas)		mm	6.35 / 9.52	6.35 / 9.52	6.35 / 9.52	6.35 / 9.52
Drain Hose Diameter (I.D./O.D.)		mm	13.8 / 15 to 16.8	13.8 / 15 to 16.8	13.8 / 15 to 16.8	13.8 / 15 to 16.8
Max. Pipe Length (Pre-Charge)		m	20 (15)	20 (15)	20 (15)	20 (15)
Max. Height Difference			15	15	15	15
Operating Range	Cooling	°CDB	-10 to 50	-10 to 50	-10 to 50	-10 to 50
	Heating	°CDB	-15 to 24	-15 to 24	-15 to 24	-15 to 24
Refrigerant	Type (Global Warming Potential)		R32 (675)	R32 (675)	R32 (675)	R32 (675)
	Charge	kg (CO2eq-T)	0.60 (0.405)	0.60 (0.405)	0.70 (0.473)	0.85 (0.574)

Optional parts

* For information on the compatibility of optional parts for Intesis products, please refer to the compatibility list at the end of the "Control system & Optional parts" chapter.

Wired Remote Controller (Design type): UTY-RVRY	Simple remote controller: UTY-RSRVZ1	Network Converter for single split (DC power supply type): UTY-VTGX
Compact wired remote controller: UTY-RCRYZ1	Wireless remote controller: UTY-LNWX	Network Converter for single split (AC power supply type): UTY-VTGXV
Wired remote controller (touch panel): UTY-RNRYZ6	Communication Kit: UTY-TWRXZ2	Silver Ion filter: UTR-FA16-5
Wired remote controller: UTY-RLRY	External Connect Kit: UTY-XWZX	External input and output PCB ¹⁾ : UTY-XCSXZ2
Simple remote controller (without operation mode): UTY-RHRYZ1	External Connect Kit: UTY-XWZXZ5	External switch controller: UTY-TERX

¹⁾ It is required when 2 or more external input and output ports are used.

Dimensions

(Unit: mm)

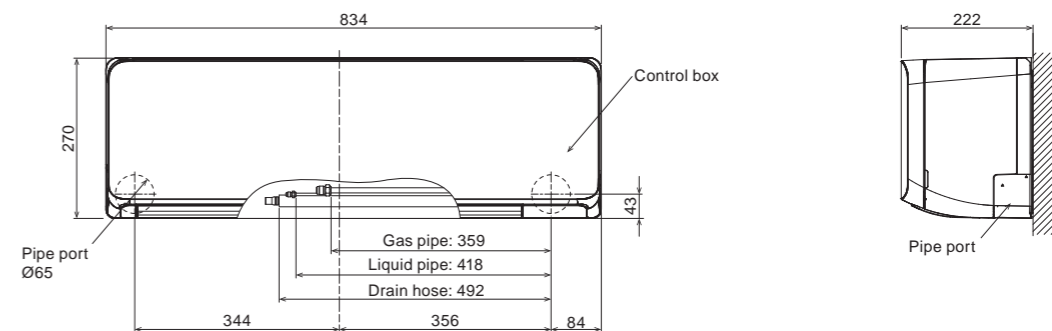

SPLIT

NEW

KM Series

Wall-Mounted

Built-in WLAN adapter model
Standard Range
High-Efficiency & Large Room



High Energy Saving

High-efficiency has been achieved by the lambda-shaped heat exchanger, large cross-flow fan, and the R32 refrigerant.

SEER 8.0 **SCOP 4.6**
*18 model

Hybrid-heat exchanger

The large hybrid heat exchanger has greatly improved the heat exchange efficiency to achieve top-level SEER and SCOP.

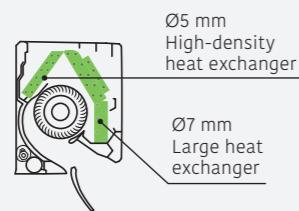

Ø107 Large cross-flow fan

The large-diameter fan generates air volume efficiently even at reduced power.

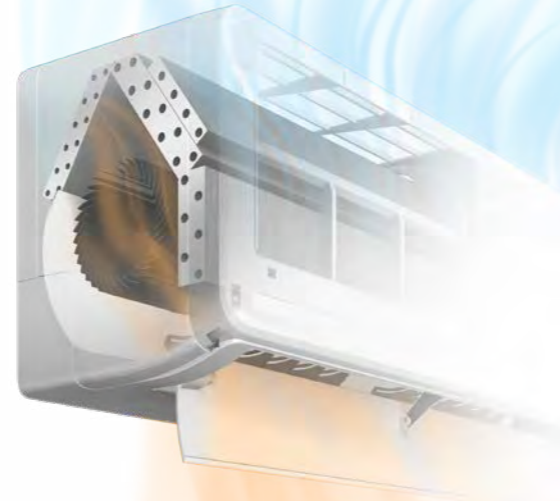
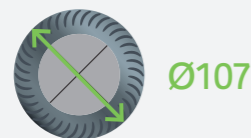

Smart Device Control

A WLAN adapter is included as standard equipment. By installing the AIRSTAGE mobile app on your smart device, you can check and control the operating status of the air conditioner from anywhere indoors or outdoors.

* For more information about smart device control, please refer to the page C-022.



You need to install the AIRSTAGE Mobile app on your smart device in order to control the air conditioner.



Easy Access to the Flare Pipe Connection

Installation when left outlet piping is easier by removable under cover of the indoor unit chassis. Installation when center outlet piping is easier by design change of wall hook bracket.

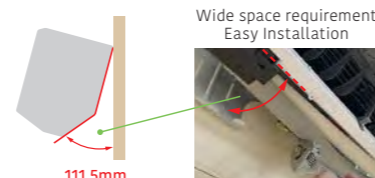

Model: ASEH18KMTGL / ASEH24KMTGL



Specifications

Model name	Indoor unit		ASEH18KMTGL		ASEH24KMTGL	
	Outdoor unit		AOEH18KMTG		AOEH24KMTG	
Power Source			Single phase, ~230 V, 50 Hz			
Capacity	Cooling	Rated	kW	5.2	7.1	
		Min.-Max.		0.9-6.0	0.9-8.3	
	Heating	Rated	6.3	8.0		
Min.-Max.		0.9-8.7	0.9-10.1			
Input Power	Cooling/Heating	kW	1.39/1.56	2.20/1.99		
EER	Cooling	W/W	3.74	3.23		
COP	Heating	W/W	4.04	4.02		
Pdesign	Cooling/Heating (-10°C)	kW	5.2/4.8	7.1/7.1		
SEER	Cooling	W/W	8.00	7.30		
SCOP	Heating (Average)	W/W	4.60	4.30		
Energy Efficiency Class	Cooling		A++	A++		
	Heating (Average)		A++	A+		
Max. Operating Current	Cooling/Heating	A	9.5/13.5	13.5/16.0		
Annual Energy Consumption	Cooling	kWh/a	227	340		
	Heating	kWh/a	1,460	2,311		
Moisture Removal		l/h	1.7	2.7		
	Indoor (Cooling)	H/M/L/Q	45/40/35/29	49/40/35/29		
Sound Pressure Level	Indoor (Heating)	H/M/L/Q	46/40/35/29	49/40/35/29		
	Outdoor (Cooling/Heating)	High	50/50	54/54		
Sound Power Level	Indoor (Cooling/Heating)	High	60/61	65/65		
	Outdoor (Cooling/Heating)	High	65/65	67/67		
Airflow Rate	Indoor/Outdoor (Cooling)	High	980/2,350	1,170/3,240		
	Indoor/Outdoor (Heating)	High	1,020/2,100	1,170/2,970		
Net Dimensions	Indoor	mm	280 × 980 × 240	280 × 980 × 240		
	Outdoor	mm	632 × 799 × 290	716 × 820 × 315		
Weight	Indoor	kg	12.5	12.5		
	Outdoor	kg	36	42		
Connection Pipe Diameter (Liquid/Gas)		mm	6.35/12.70	6.35/12.70		
Drain Hose Diameter (I.D./O.D.)			13.8/15.8 to 16.7	13.8/15.8 to 16.7		
Max. Pipe Length (Pre-Charge)		m	25 (15)	30 (15)		
Max. Height Difference			20	25		
Operating Range	Cooling	°CDB	-10 to 50*	-10 to 50*		
	Heating	°CDB	-15 to 24	-15 to 24		
Refrigerant	Type (Global Warming Potential)		R32 (675)	R32 (675)		
	Charge	kg (CO2eq-T)	1.02 (0.689)	1.32 (0.891)		

*Outside air intake temperature

Optional parts

* For information on the compatibility of optional parts for Intesis products, please refer to the compatibility list at the end of the "Control system & Optional parts" chapter.

Wired Remote Controller (Design type):	UTY-RVRY	Simple remote controller:	UTY-RSRYZ1	Network Converter for single split (DC power supply type):	UTY-VTGX
Compact wired remote controller:	UTY-RCRYZ1	Wireless remote controller:	UTY-LNWX	Network Converter for single split (AC power supply type):	UTY-VTGXV
Wired remote controller (touch panel):	UTY-RNRYZ6	Communication Kit:	UTY-TWRXZ2	Silver Ion filter:	UTR-FA16-5
Wired remote controller:	UTY-RLRY	External input and output PCB*1:	UTY-XCSXZ2	External switch controller:	UTY-TERX
Simple remote controller (without operation mode):	UTY-RHRYZ1	External Connect Kit:	UTY-XWZXZ5		

*1 It is required when 2 or more external input and output ports are used.

Dimensions

(Unit: mm)

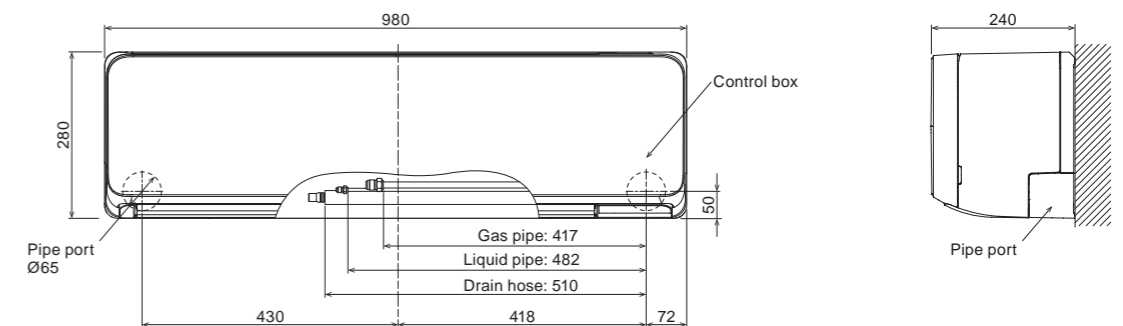

SPLIT

KN Series

Wall-Mounted

Built-in WLAN adapter model
ECO Range
Compact Size



Elegant & Smart Square Design

An elegant and smart type in the eco range. The delicate shading of the ridge line makes the unit an accessory for the room.



High Energy Saving

The size of the heat exchanger has increased to improve performance, making it more powerful despite its compact size.

Class Cooling A++ Heating A+

SEER 7.8* SCOP 4.4

* 07 model

Comfortable Airflow & Quiet Operation

The large louver and the air-blowing structure create a comfortable air flow that spreads all the way down to the user's feet with quiet operation.



Smart Device Control

A WLAN adapter is included as standard equipment. By installing the AIRSTAGE mobile app on your smart device, you can check and control the operating status of the air conditioner from anywhere indoors or outdoors.

* See page C-022 for details on smart device control.

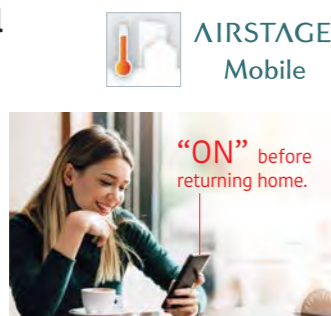

Highly Efficient Operation Even at High Outdoor Temperatures

Operating range MAX 50°C (Cooling operation)

Even when installed in the region with high outdoor air temperatures (Max. 50°C*), it is comfortable because it can cool the interior well.

* suction temperature of the outdoor unit



Model: ASEH07KNCA / ASEH09KNCA / ASEH12KNCA



Specifications

Model name	Indoor unit		ASEH07KNCA		ASEH09KNCA		ASEH12KNCA		
	Outdoor unit		AOEH07KNCA		AOEH09KNCA		AOEH12KNCA		
Power Source	Single phase, ~230 V, 50 Hz								
Capacity	Cooling	Rated	2.0		2.5		3.4		
		Min.-Max.	0.9-2.9		0.9-3.1		0.9-3.8		
	Heating	Rated	2.5		2.8		3.8		
Min.-Max.		0.9-3.4		0.9-4.0		0.9-4.8			
Input Power	Cooling/Heating	kW		0.50 / 0.58		0.74 / 0.70		1.05 / 1.02	
EER	Cooling	W/W		4.00		3.38		3.24	
		W/W		4.31		4.00		3.73	
COP	Heating	W/W		4.31		4.00		3.73	
		W/W		4.4		4.4		4.4	
Pdesign	Cooling/Heating (-10°C)	kW		2.0 / 2.3		2.5 / 2.4		3.4 / 2.5	
SEER	Cooling	W/W		7.8		7.4		7.0	
		W/W		4.4		4.4		4.4	
SCOP	Heating (Average)	W/W		4.4		4.4		4.4	
		W/W		4.4		4.4		4.4	
Energy Efficiency Class	Cooling	Class		A++		A++		A++	
		Class		A+		A+		A+	
Max. Operating Current	Cooling/Heating	A		6.5 / 9.0		6.5 / 9.0		6.5 / 9.0	
		A		6.5 / 9.0		6.5 / 9.0		6.5 / 9.0	
Annual Energy Consumption	Cooling	kWh/a		90		118		170	
		kWh/a		731		763		795	
Moisture Removal	Cooling	l/h		1.0		1.0		1.4	
		l/h		1.0		1.0		1.4	
Sound Pressure Level	Indoor (Cooling)	H/M/L/Q	36 / 33 / 29 / 20		38 / 35 / 29 / 20		40 / 36 / 32 / 20		
		H/M/L/Q	38 / 33 / 30 / 22		38 / 33 / 30 / 22		39 / 35 / 31 / 22		
	Outdoor (Cooling/Heating)	High	43 / 44		44 / 45		49 / 49		
Sound Power Level	Indoor (Cooling/Heating)	High	51 / 52		53 / 52		55 / 53		
		High	53 / 54		56 / 56		60 / 61		
	Outdoor (Cooling/Heating)	High	530 / 1,430		580 / 1,430		600 / 1,460		
Airflow Rate	Indoor/Outdoor (Cooling)	High	580 / 1,390		580 / 1,390		600 / 1,360		
		High	580 / 1,390		580 / 1,390		600 / 1,360		
Net Dimensions	Indoor	mm		270 × 784 × 222		270 × 784 × 222		270 × 784 × 222	
		mm		541 × 663 × 290		541 × 663 × 290		541 × 663 × 290	
H x W x D	Outdoor	mm		541 × 663 × 290		541 × 663 × 290		541 × 663 × 290	
		mm		541 × 663 × 290		541 × 663 × 290		541 × 663 × 290	
Weight	Indoor	kg		9		9		9	
		kg		22		22		24	
Connection Pipe Diameter (Liquid/Gas)	Indoor	mm		6.35 / 9.52		6.35 / 9.52		6.35 / 9.52	
		mm		13.8 / 15 to 16.8		13.8 / 15 to 16.8		13.8 / 15 to 16.8	
Drain Hose Diameter (I.D./O.D.)	Indoor	mm		13.8 / 15 to 16.8		13.8 / 15 to 16.8		13.8 / 15 to 16.8	
		mm		13.8 / 15 to 16.8		13.8 / 15 to 16.8		13.8 / 15 to 16.8	
Max. Pipe Length (Pre-Charge)	Indoor	m		20 (15)		20 (15)		20 (15)	
		m		20 (15)		20 (15)		20 (15)	
Max. Height Difference	Indoor	m		15		15		15	
		m		15		15		15	
Operating Range	Cooling	°CDB		-10 to 50		-10 to 50		-10 to 50	
		°CDB		-10 to 50		-10 to 50		-10 to 50	
Refrigerant	Type (Global Warming Potential)	R32 (675)		R32 (675)		R32 (675)		R32 (675)	
		Charge		kg (CO2eq-T)		0.57 (0.385)		0.57 (0.385)	

Optional parts

* For information on the compatibility of optional parts for Intesis products, please refer to the compatibility list at the end of the "Control system & Optional parts" chapter.

Wireless remote controller: UTY-LNWX
Silver Ion Filter: UTR-FA16-5

Dimensions

(Unit: mm)

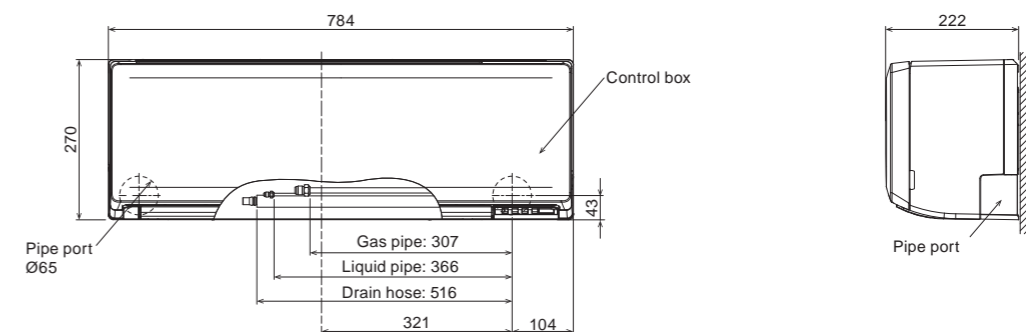

SPLIT

NEW

KL Series

Wall-Mounted

Built-in WLAN adapter model
ECO Range
Cooling-enhanced type



Model: ASEH07KLTL / ASEH09KLTL / ASEH12KLTL



Specifications

Model name	Indoor unit		kW	ASEH07KLTL	ASEH09KLTL	ASEH12KLTL
	Outdoor unit			AOEH07KLTA	AOEH09KLTA	AOEH12KLTA
Power Source				Single phase, ~230 V, 50 Hz		
Capacity	Cooling	Rated	kW	2.0	2.5	3.4
		Min.-Max.		0.9-2.8	0.9-3.0	0.9-3.7
	Heating	Rated	kW	2.4	2.5	3.4
		Min.-Max.		0.9-3.3	0.9-3.5	0.9-3.7
Input Power	Cooling/Heating		kW	0.54 / 0.64	0.76 / 0.67	1.05 / 0.915
EER	Cooling		W/W	3.70	3.29	3.24
COP	Heating		W/W	3.75	3.73	3.72
Pdesign	Cooling/Heating (-10°C)		kW	2.0 / 2.2	2.5 / 2.3	3.4 / 2.5
SEER	Cooling		W/W	7.10	6.80	6.70
SCOP	Heating (Average)		W/W	4.10	4.10	4.10
Energy Efficiency Class	Cooling			A++	A++	A++
	Heating (Average)			A+	A+	A+
Max. Operating Current	Cooling/Heating		A	6.0 / 6.0	6.0 / 6.0	7.0 / 7.0
Annual Energy Consumption	Cooling		kWh/a	99	129	178
	Heating		kWh/a	752	786	854
Moisture Removal			l/h	0.18	0.55	1.26
	Indoor (Cooling)	H/M/L/Q		41 / 36 / 29 / 21	43 / 36 / 29 / 21	43 / 37 / 30 / 21
Sound Pressure Level	Indoor (Heating)	H/M/L/Q		41 / 37 / 32 / 23	43 / 37 / 32 / 23	43 / 37 / 32 / 23
	Outdoor (Cooling/Heating)	High	dB(A)	47 / 47	47 / 47	50 / 50
Sound Power Level	Indoor (Cooling/Heating)	High		56 / 56	56 / 56	56 / 57
	Outdoor (Cooling/Heating)	High		56 / 57	58 / 57	60 / 61
Airflow Rate	Indoor/Outdoor (Cooling)	High	m ³ /h	600 / 1,650	620 / 1,650	620 / 1,700
	Indoor/Outdoor (Heating)	High	m ³ /h	600 / 1,450	620 / 1,450	640 / 1,470
Net Dimensions H x W x D	Indoor	mm		250 x 770 x 218	250 x 770 x 218	250 x 770 x 218
	Outdoor	mm		541 x 663 x 290	541 x 663 x 290	541 x 663 x 290
Weight	Indoor	kg		7.0	7.0	7.5
	Outdoor	kg		19	19	22
Connection Pipe Diameter (Liquid/Gas)			mm	6.35 / 9.52	6.35 / 9.52	6.35 / 9.52
Drain Hose Diameter (I.D./O.D.)				13.8 / 15 to 16.8	13.8 / 15 to 16.8	13.8 / 15 to 16.8
Max. Pipe Length (Pre-Charge)			m	20 (15)	20 (15)	20 (15)
Max. Height Difference				15	15	15
Operating Range	Cooling	°CDB		10 to 52	10 to 52	10 to 52
	Heating	°CDB		-15 to 24	-15 to 24	-15 to 24
Refrigerant	Type (Global Warming Potential)			R32 (675)	R32 (675)	R32 (675)
	Charge		kg (CO2eq-T)	0.53(0.358)	0.53(0.358)	0.60(0.405)

Highly Efficient Operation Even at High Outdoor Temperatures

Even when installed in the region with high outdoor air temperatures (Max. 52°C*), it is comfortable because it can cool the interior well.

*suction temperature of the outdoor unit



SEER 7.1*
*07 model



MINIMAL SMART Design

The smart design eliminates mechanical elements and offers a sophisticated, premium impression. Its compact size, with a width of 770 mm, allows for flexible installation in limited room space.



Comfortable Airflow & Quiet Operation

The large louver and the air-blowing structure create a comfortable air flow that spreads all the way down to the user's feet with quiet operation.



Smart Device Control

A WLAN adapter is included as standard equipment. By installing the AIRSTAGE mobile app on your smart device, you can check and control the operating status of the air conditioner from anywhere indoors or outdoors.

* For more information about smart device control, please refer to the page C-022.



AIRSTAGE Mobile

You need to install the AIRSTAGE Mobile app on your smart device in order to control the air conditioner.



Optional parts

* For information on the compatibility of optional parts for Intesis products, please refer to the compatibility list at the end of the "Control system & Optional parts" chapter.

Wireless remote controller: UTY-LNWX

Silver Ion Filter: UTR-FA16-5

Dimensions

(Unit: mm)

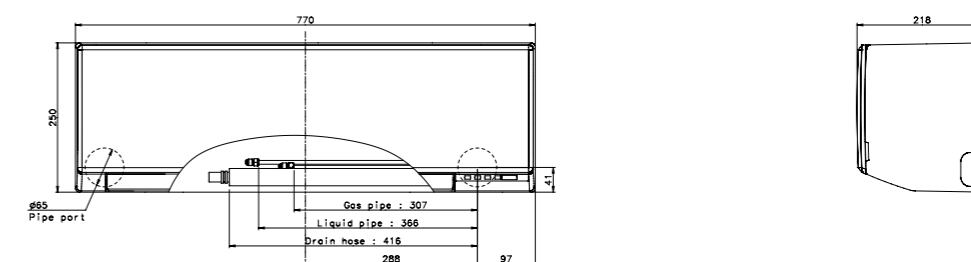

SPLIT

NEW

KL Series

Wall-Mounted

Built-in WLAN adapter model
ECO Range
Comfort for Large Room



Narrow Width & Compact Design

Compact and versatile. Powerful airflow is realized despite the 790-mm width compact design for small spaces such as bedrooms or home offices.

Economy Operation

Set temperature automatically increases or decreases by 1°C. The thermostat setting is adjusted automatically according to the room temperature to avoid unnecessary cooling or heating.

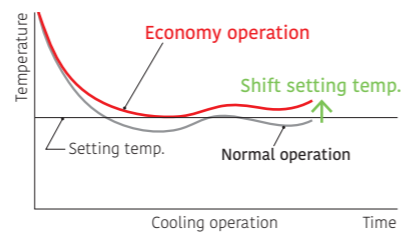

Powerful Operation

In powerful operation mode, the compressor operates at maximum speed for 20 minutes to provide a powerful airflow. Rapid cooling and heating makes the room comfortable quickly.

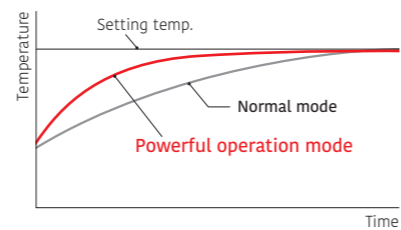

Smart Device Control

A WLAN adapter is included as standard equipment. By installing the AIRSTAGE mobile app on your smart device, you can check and control the operating status of the air conditioner from anywhere indoors or outdoors.

* For more information about smart device control, please refer to the page C-022.



Low Ambient Operation

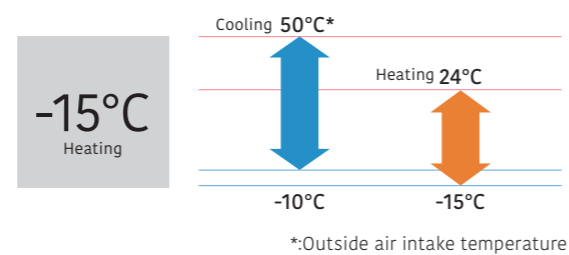

Model: ASEH18KLCBL / ASEH24KLCBL



WLAN adapter (Built-in)



Wireless RC



For ASEH18KLCBL



For ASEH24KLCBL



Specifications

Model name	Indoor unit		ASEH18KLCBL		ASEH24KLCBL	
	Outdoor unit		AOEH18KLCB		AOEH24KLCB	
Power Source			Single phase, ~230 V, 50 Hz			
Capacity	Cooling	Rated	kW	5.2	7.1	
		Min.-Max.		0.9-5.5	0.9-7.7	
	Heating	Rated	6.3	8.0		
Min.-Max.		0.6-7.6	0.9-9.0			
Input Power	Cooling/Heating	kW	1.730/1.80	2.42/2.23		
EER	Cooling	W/W	3.01	2.93		
COP	Heating	W/W	3.50	3.59		
Pdesign	Cooling/Heating (-10°C)	kW	5.20/4.80	7.10/7.10		
SEER	Cooling	W/W	7.40	7.20		
SCOP	Heating (Average)	W/W	4.30	4.00		
Energy Efficiency Class	Cooling		A++	A++		
	Heating (Average)		A+	A+		
Max. Operating Current	Cooling/Heating	A	9.5/13.5	13.5/17.5		
Annual Energy Consumption	Cooling	kWh/a	246	345		
	Heating		1,560	2,482		
Moisture Removal		l/h	1.9	3.1		
	Indoor (Cooling)	H/M/L/Q	47/44/40/35	51/45/38/33		
Sound Pressure Level	Indoor (Heating)	H/M/L/Q	50/45/41/37	52/45/41/37		
	Outdoor (Cooling/Heating)	High	50/56	55/57		
Sound Power Level	Indoor (Cooling/Heating)	High	60/65	64/65		
	Outdoor (Cooling/Heating)	High	61/66	65/67		
Airflow Rate	Indoor/Outdoor (Cooling)	High	865/1,830	1,040/2,885		
	Indoor/Outdoor (Heating)	High	995/2,265	1,040/3,030		
Net Dimensions H x W x D	Indoor	mm	293 x 790 x 249	293 x 790 x 249		
	Outdoor	mm	542 x 799 x 290	632 x 799 x 290		
Weight	Indoor	kg	9.5	10.0		
	Outdoor	kg	32	38		
Connection Pipe Diameter (Liquid/Gas)		mm	6.35/9.52	6.35/12.70		
Drain Hose Diameter (I.D./O.D.)			13.8/15.8 to 16.7	13.8/15.8 to 16.7		
Max. Pipe Length (Pre-Charge)		m	25 (15)	30 (15)		
Max. Height Difference			20	25		
Operating Range	Cooling	°CDB	-10 to 50*	-10 to 50*		
	Heating		-15 to 24	-15 to 24		
Refrigerant	Type (Global Warming Potential)		R32 (675)	R32 (675)		
	Charge	kg (CO2eq-T)	0.85 (0.574)	1.10 (0.743)		

*Outside air intake temperature

Optional parts

* For information on the compatibility of optional parts for Intesis products, please refer to the compatibility list at the end of the "Control system & Optional parts" chapter.

Wireless remote controller: UTY-LNWX
Silver Ion Filter: UTR-FA16-5

Dimensions

(Unit: mm)

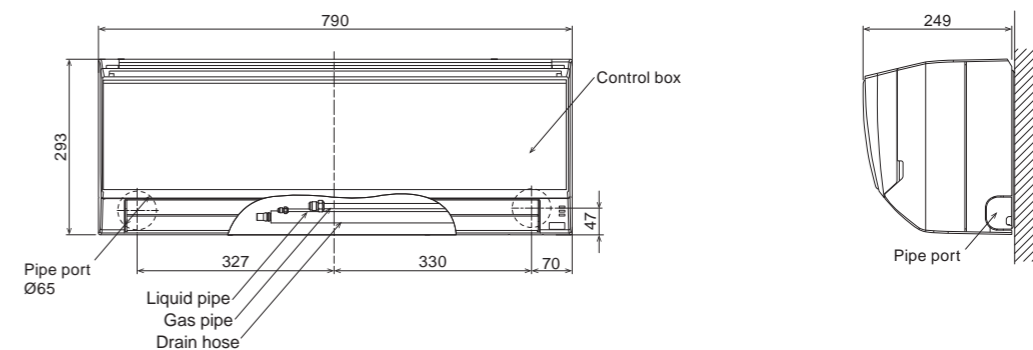

SPLIT

KM Series

Wall-Mounted Standard Range

High-Efficiency & Large Room



Special Cooling

When it is necessary to be constantly cooled such as rooms with a high heat load, it is possible to operate the cooling with keeping performance even when the outside temperature is low.

- * Wired remote controller (UTY-RNRYZ6) is required.
- * Please note that we will not provide compensation for any damages suffered to your appliances or data as a result of using this function.
- * Please use it in low-humidity environments. Condensation and other problems may be caused when used in high-humidity environments.



Occupancy Sensor

The Occupancy sensor monitors the movements of people in a room and operates the air conditioner at a lower capacity when people leave the room. When people come back to the room, it automatically returns to the previous operating mode.

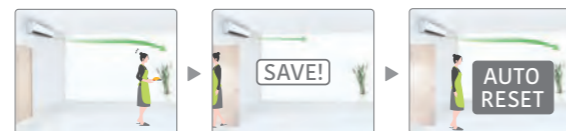

Refrigerant Cycle Monitor (Option)

Wired Remote Controller (Touch Panel) will support to display some sensor values for maintenance and service support.

*Wired remote controller (UTY-RNRYZ6 or UTY-RVRY) is required.

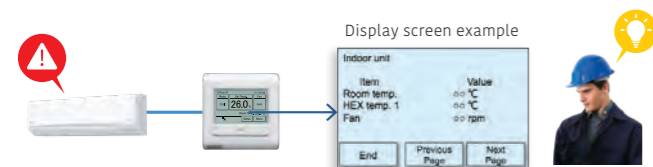

Smart Device Control (Option)

With the optional WLAN adapter installed in the air conditioner, you can control it from anywhere with your smart device.

* For more information about smart device control, please refer to the page C-022.



Model: ASEH30KMTB / ASEH36KMTB



Specifications

Model name	Indoor unit		ASEH30KMTB		ASEH36KMTB	
	Outdoor unit		AOEH30KMTB		AOEH36KMTB	
Power Source			Single phase, ~230V, 50Hz			
Capacity	Cooling	Rated	kW	8.0	9.4	
		Min.-Max.		2.9-9.0	2.9-10.0	
	Heating	Rated	8.8	10.1		
Min.-Max.		2.2-11.8	2.7-12.6			
Input Power	Cooling/Heating	kW	2.33/2.20	3.16/2.73		
EER	Cooling		3.43	2.97		
COP	Heating	W/W	4.00	3.70		
Pdesign	Cooling/Heating (-10°C)	kW	8.0/6.5	9.4/7.1		
SEER	Cooling	W/W	6.68	6.10		
SCOP	Heating (Average)		4.50	4.50		
Energy Efficiency Class	Cooling		A++	A++		
	Heating (Average)		A+	A+		
Max. Operating Current	Cooling/Heating	A	21.0/21.0	21.5/21.5		
Annual Energy Consumption	Cooling	kWh/a	419	534		
	Heating		1,994	2,189		
Moisture Removal		l/h	2.6	3.8		
	Indoor (Cooling)	H/M/L/Q	50/44/40/33	50/44/40/33		
Sound Pressure Level	Indoor (Heating)	H/M/L/Q	49/44/39/33	49/44/39/33		
	Outdoor (Cooling/Heating)	High	53/55	55/55		
Sound Power Level	Indoor (Cooling/Heating)	High	65/65	65/65		
	Outdoor (Cooling/Heating)	High	68/69	70/70		
Airflow Rate	Indoor/Outdoor (Cooling)	High	1,330/3,750	1,330/3,750		
	Indoor/Outdoor (Heating)	High	1,330/3,750	1,330/3,750		
Net Dimensions	Indoor	mm	340 × 1,150 × 280	340 × 1,150 × 280		
	Outdoor	mm	788 × 940 × 320	788 × 940 × 320		
Weight	Indoor	kg	18.5	18.5		
	Outdoor	kg	52.0	52.0		
Connection Pipe Diameter (Liquid/Gas)		mm	9.52/15.88	9.52/15.88		
Drain Hose Diameter (I.D./O.D.)			13.8/15.8 to 16.7	13.8/15.8 to 16.7		
Max. Pipe Length (Pre-Charge)		m	50(30)	50(30)		
Max. Height Difference			30	30		
Operating Range	Cooling	°CDB	-15to46	-15to46		
	Heating		-15to24	-15to24		
Refrigerant	Type (Global Warming Potential)		R32(675)	R32(675)		
	Charge	kg (CO2eq-T)	1.90(1.283)	1.90(1.283)		

Optional parts

* For information on the compatibility of optional parts for Intesis products, please refer to the compatibility list at the end of the "Control system & Optional parts" chapter.

Wired Remote Controller (Design type): UTY-RVRY	Wireless remote controller: UTY-LNWX	Network Converter for single split (DC power supply type): UTY-VTGX
Compact wired remote controller: UTY-RCRYZ1	Communication Kit: UTY-TWRXZ2	Network Converter for single split (AC power supply type): UTY-VTGXV
Wired remote controller (touch panel): UTY-RNRYZ6	External input and output PCB*: UTY-XCSXZ2	External switch controller: UTY-TERX
Wired remote controller: UTY-RLRY	WLAN adapter: UTY-TFSXF2	External Connect Kit: UTY-XWXZ5
Simple remote controller (without operation mode): UTY-RHRYZ1		
Simple remote controller: UTY-RSRYZ1	Silver Ion filter: UTY-FA13-3	

*1 It is required when 2 or more external input and output ports are used.

Dimensions

(Unit: mm)

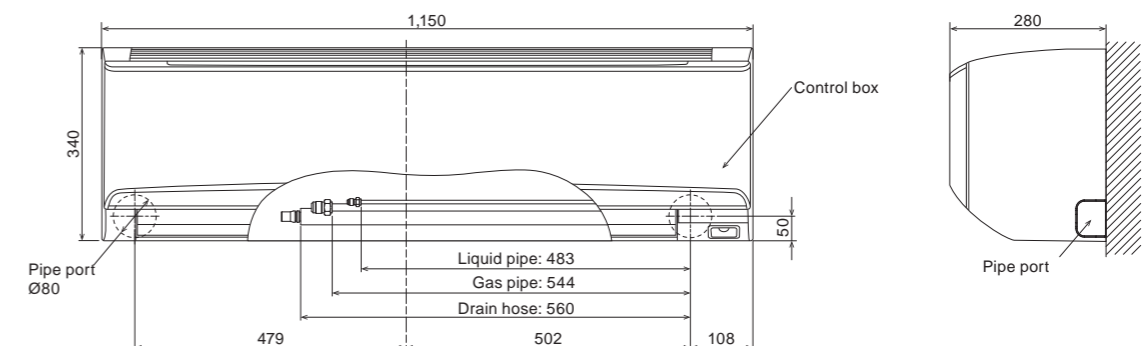

Cassette

Compact 4-way
Flow Range
Fits grid ceiling



Compact and Stylish Panel Design

The compact and stylish panel fits nicely into a grid-type ceiling. Its linear design is a perfect fit into a grid of 620 mm × 620 mm in the ceiling.



Easy Maintenance

You can access the unit for maintenance simply by removing a ceiling panel next to the grille. As no inspection hole needs to be cut through the ceiling, no additional construction cost is incurred.

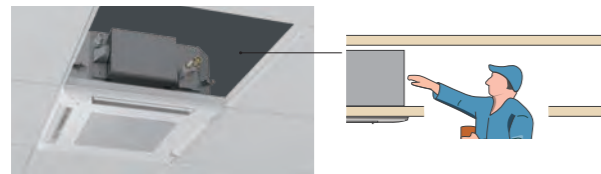

The air inlet grille can be installed to open in any direction for easy maintenance.



Flexible Installation

The unit fits nicely into the decor of a grid-type ceiling and can be installed near the lighting or a ventilation opening.



Link Up with a Variety of Central Control System (Option)

Centralized control including facilities and equipment in addition to air conditioning is possible by linking up with MODBUS, KNX interfaces.



Model: AUXG09KVLA / AUXG12KVLA / AUXG14KVLA / AUXG18KVLA / AUXG22KVLA / AUXG24KVLA



Specifications

Model name	Indoor unit		AUXG09KVLA	AUXG12KVLA	AUXG14KVLA	AUXG18KVLA	AUXG22KVLA	AUXG24KVLA
	Outdoor unit		AOEG09KBTB	AOEG12KBTB	AOEG14KBTB	AOEG18KBTB	AOEG22KBTB	AOEG24KBTB
Power Source			Single phase, ~230 V, 50 Hz					
Capacity	Cooling	Rated	2.5	3.5	4.3	5.2	6.0	6.8
		Min.-Max.	0.9-3.2	0.9-4.4	0.9-5.4	0.9-5.9	0.9-6.7	0.9-8.0
	Heating	Rated	3.2	4.1	5.0	6.0	7.0	7.5
Min.-Max.		0.9-4.7	0.9-5.7	0.9-6.5	0.9-7.5	0.9-8.0	0.9-9.1	
EER	Cooling	4.57	3.76	3.36	3.25	3.30	3.08	
COP	Cooling	4.05	3.80	3.79	3.61	3.74	3.69	
	Heating	4.40	4.30	4.40	4.20	4.30	4.00	
Pdesign	Cooling/Heating (-10°C)	2.5/2.6	3.5/3.4	4.3/3.8	5.2/4.4	6.0/4.8	6.8/6.0	
SEER	Cooling	6.70	6.60	6.50	6.60	6.60	6.10	
	Heating (Average)	4.40	4.30	4.40	4.20	4.30	4.00	
Energy Efficiency Class	Cooling	A++	A++	A++	A++	A++	A++	
	Heating (Average)	A+	A+	A+	A+	A+	A+	
Max. Operating Current	Cooling/Heating	7.9/7.9	9.7/9.7	10.2/10.2	12.1/12.1	12.6/12.6	13.6/13.6	
Annual Energy Consumption	Cooling	131	186	231	275	318	390	
	Heating	826	1,106	1,208	1,466	1,562	2,097	
Moisture Removal	Cooling	0.6	1.2	1.5	2.2	2.6	2.7	
	Heating	0.6	1.2	1.5	2.2	2.6	2.7	
Sound Pressure Level	Indoor (Cooling)	H/M/L/Q	33/31/29/27	37/34/30/27	38/34/30/27	38/34/30/26	44/42/36/30	49/44/36/30
	Indoor (Heating)	H/M/L/Q	34/32/29/27	37/34/31/29	43/38/34/30	43/38/34/30	45/43/40/33	49/45/40/33
Sound Power Level	Outdoor (Cooling/Heating)	High	46/46	47/47	49/49	50/50	51/51	53/54
	Indoor (Cooling/Heating)	High	46/47	49/49	50/55	50/55	56/57	59/61
Airflow Rate	Indoor/Outdoor (Cooling)	High	540/1,480	600/1,580	680/1,670	680/2,160	830/2,240	930/2,700
	Indoor/Outdoor (Heating)	High	540/1,410	600/1,520	800/1,580	800/1,830	860/1,960	930/2,700
Net Dimensions H x W x D	Indoor	mm	245 × 570 × 570	245 × 570 × 570	245 × 570 × 570	245 × 570 × 570	245 × 570 × 570	245 × 570 × 570
	Outdoor	mm	542 × 799 × 290	542 × 799 × 290	542 × 799 × 290	632 × 799 × 290	632 × 799 × 290	716 × 820 × 315
Weight	Indoor	kg	15	15	15	15	16	16
	Outdoor	kg	32	33	33	36	38	42
Connection Pipe Diameter (Liquid/Gas)	Cooling	mm	6.35/9.52	6.35/9.52	6.35/9.52	6.35/12.70	6.35/12.70	6.35/12.70
	Heating	mm	25/32	25/32	25/32	25/32	25/32	25/32
Max. Pipe Length (Pre-Charge)		m	20 (15)	25 (15)	25 (15)	30 (20)	30 (20)	30 (20)
Max. Height Difference	Cooling	°CDB	-15 to 46	-15 to 46	-15 to 46	-15 to 46	-15 to 46	-15 to 46
	Heating	°CDB	-15 to 24	-15 to 24	-15 to 24	-15 to 24	-15 to 24	-15 to 24
Refrigerant	Type (Global Warming Potential)		R32 (675)	R32 (675)	R32 (675)	R32 (675)	R32 (675)	R32 (675)
	Charge	kg (CO2eq-t)	0.85 (0.574)	0.85 (0.574)	0.85 (0.574)	1.02 (0.689)	1.25 (0.844)	1.25 (0.844)
Cassette Grille	Model name		UTG-UFYF-W	UTG-UFYF-W	UTG-UFYF-W	UTG-UFYF-W	UTG-UFYF-W	UTG-UFYF-W
	Dimensions (H × W × D)	mm	49 × 620 × 620	49 × 620 × 620	49 × 620 × 620	49 × 620 × 620	49 × 620 × 620	49 × 620 × 620
Weight		kg	2.3	2.3	2.3	2.3	2.3	2.3

Optional parts

* For information on the compatibility of optional parts for Intesis products, please refer to the compatibility list at the end of the "Control system & Optional parts" chapter.

Wired Remote Controller (Design type): UTY-RVRY	Wireless remote controller: UTY-LNTY	Network Converter for single split (DC power supply type): UTY-VTGX
Compact wired remote controller: UTY-RCRYZ1	External switch controller: UTY-TERX	Network Converter for single split (AC power supply type): UTY-VTGVX
Wired remote controller (touch panel): UTY-RNRY26	WLAN adapter: UTY-TFSXZ1	Insulation Kit for high humidity: UTZ-KXGC
Wired remote controller: UTY-RLRY	UTY-TFSXJ3	External input and output PCB: UTY-XCSX
UTY-RNNYM	Air Outlet Shutter Plate: UTR-YDZB	External input and output PCB box: UTZ-GXRA
UTY-RVNYM	Cassette Grille: UTG-UFYF-W	Silver Ion Filter: UTD-HFAA
Simple remote controller (without operation mode): UTY-RHRYZ1	Fresh Air Intake Kit: UTZ-VXAA	
Simple remote controller: UTY-RSRYZ1	External Connect Kit: UTY-XWZXXG	

Dimensions

(Unit: mm)

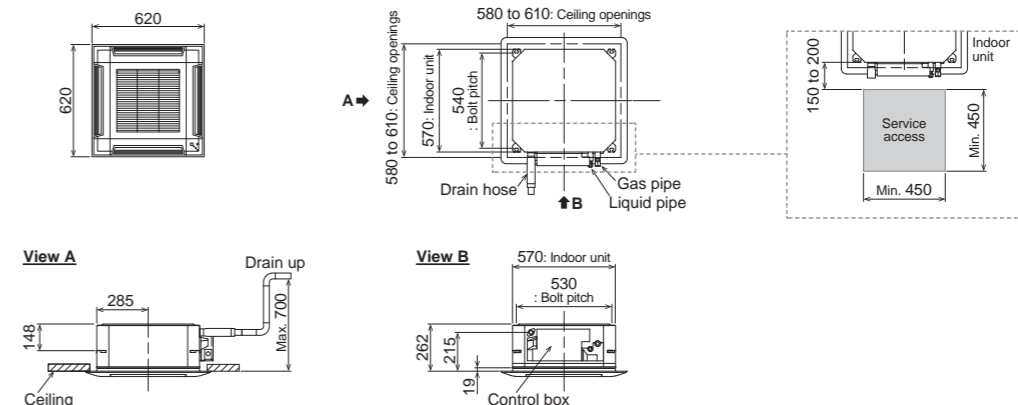



Cassette

Circular Flow Range
Comfort for Large Room



Unique Circular Flow Design

The Cassette model realizes a Circular Flow to blow a large airflow in a 360° direction by using a high-performance DC fan motor, turbo fan, and a unique seamless airflow louver design.

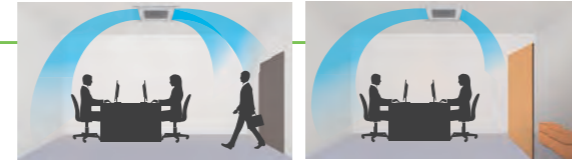

Airflows avoid blowing cool air directly at the occupants in the room, providing more comfortable air conditioning.
Provides efficient air conditioning based on the room layout

Individual Louver Control

Each louver can be controlled individually with a wired remote controller equipped with a touch panel to provide different directional airflows according to the room layout.
*Wired remote controller (touch panel) (UTY-RNRYZ6) only

The Occupancy sensor yields more energy savings.
Energy saving operation starts automatically by detecting the motion of a person. Two modes of save operation mode and stop mode can be selected.

Compact and Lightweight Outdoor Unit

The outdoor units for the 45,000 BTU and 54,000 BTU models have been completely redesigned. Easier installation is achieved for this compact and lightweight outdoor unit.

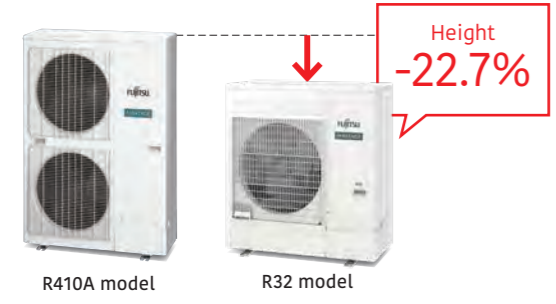

Link Up with a Variety of Central Control System (Option)

Centralized control including facilities and equipment in addition to air conditioning is possible by linking up with MODBUS, KNX interfaces.



Various Cassette Grilles

Both black and white grilles are available. Three types of grilles are available: a white grille with a remote controller; a white grille without a remote controller; and a black grille without a remote controller. Select to match the atmosphere and/or usage of the room.



Model: AUXG18KRLB / AUXG22KRLB / AUXG24KRLB / AUXG30KRLB / AUXG36KRLB / AUXG45KRLB / AUXG54KRLB AUXG36KRLB [3-phase] / AUXG45KRLB [3-phase] / AUXG54KRLB [3-phase]



Specifications

Model name	Indoor unit							Outdoor unit				
	AUXG18KRLB	AUXG22KRLB	AUXG24KRLB	AUXG30KRLB	AUXG36KRLB	AUXG45KRLB	AUXG54KRLB	AUXG36KRTA	AUXG45KRTA	AUXG54KRTA		
Power Source	Single phase, ~230 V, 50 Hz							3-phase, ~400 V, 50 Hz				
Capacity	Cooling	Rated	5.2	6.0	6.8	8.5	9.5	12.1	13.4	9.5	12.1	13.4
		Min.-Max.	0.9-5.9	0.9-6.7	0.9-8.0	2.8-10.0	2.8-11.2	4.0-14.0	4.5-14.5	2.8-11.2	4.0-14.0	4.5-14.5
	Heating	Rated	6.0	7.0	7.5	10.0	10.8	13.5	13.7	10.8	13.5	15.5
		Min.-Max.	0.9-7.5	0.9-8.0	0.9-9.1	2.7-11.2	2.7-12.7	4.2-16.2	4.7-16.5	2.7-12.7	4.2-16.2	4.7-16.5
Input Power	Cooling/Heating	kW	1.36/1.58	1.71/1.82	1.89/1.90	2.44/2.51	2.91/2.45	3.61/3.21	4.41/4.16	2.91/2.45	3.61/3.21	4.41/4.16
EER	Cooling		3.82	3.51	3.60	3.49	3.26	3.35	3.04	3.26	3.35	3.04
COP	Heating	W/W	3.80	3.85	3.95	3.98	4.40	4.20	3.73	4.40	4.20	3.73
Pdesign	Cooling/Heating (-10°C)	kW	5.2/4.4	6.0/4.8	6.8/6.0	8.5/8.0	9.5/8.7	12.1/9.2	13.4/9.5	9.5/8.7	12.1/9.2	13.4/9.5
SEER	Cooling		7.00	7.00	6.60	6.70	6.55	6.65	6.53	6.55	6.65	6.53
SCOP	Heating (Average)	W/W	4.30	4.40	4.20	4.30	4.30	4.33	4.31	4.30	4.33	4.31
Energy Efficiency Class	Cooling		A++	A++	A++	A++	A++	-	-	A++	-	-
	Heating (Average)		A+	A+	A+	A+	A+	-	-	A+	-	-
ηc		%	-	-	-	-	-	263.0	258.2	-	263.0	258.2
ηh		%	-	-	-	-	-	170.2	169.4	-	170.2	169.4
Max. Operating Current	Cooling/Heating	A	12.1/12.1	12.6/12.6	13.6/13.6	22.6/22.6	22.6/22.6	28.5/28.5	28.5/28.5	10.5/10.5	14.0/14.0	14.0/14.0
Annual Energy Consumption	Cooling	kWh/a	260	300	360	444	507	-	-	507	-	-
	Heating		1,431	1,527	1,999	2,601	2,828	-	-	2,828	-	-
Moisture Removal		l/h	1.5	2.2	2.7	2.5	3.3	4.5	5.0	3.3	4.5	5.0
Sound Pressure Level	Indoor (Cooling)	H/M/L/Q	33/32/31/28	33/32/31/28	35/33/32/29	40/38/36/33	44/41/38/34	46/42/39/35	47/43/40/36	44/41/38/34	46/42/39/35	47/43/40/36
	Indoor (Heating)	H/M/L/Q	33/32/31/28	33/32/31/28	35/33/32/29	40/38/36/33	44/41/38/34	46/42/39/35	47/43/40/36	44/41/38/34	46/42/39/35	47/43/40/36
Sound Power Level	Outdoor (Cooling/Heating)	High	50/50	51/51	53/54	53/55	55/55	57/57	57/59	55/55	57/57	57/59
	Indoor (Cooling/Heating)	High	47/47	49/49	49/49	54/54	58/58	60/60	61/61	58/58	60/60	61/61
Airflow Rate	Indoor/Outdoor (Cooling)	High	1,050/2,160	1,050/2,240	1,150/2,700	1,600/3,750	1,870/3,750	2,000/4,450	2,100/4,450	1,870/3,750	2,000/4,450	2,100/4,450
	Indoor/Outdoor (Heating)	High	1,050/1,830	1,050/1,960	1,150/2,700	1,600/3,750	1,870/3,750	2,000/4,450	2,100/4,450	1,870/3,750	2,000/4,450	2,100/4,450
Net Dimensions	Indoor	H x W x D	246 × 840 × 840	246 × 840 × 840	246 × 840 × 840	288 × 840 × 840	288 × 840 × 840	288 × 840 × 840	288 × 840 × 840	288 × 840 × 840	288 × 840 × 840	288 × 840 × 840
	Outdoor		632 × 799 × 290	632 × 799 × 290	716 × 820 × 315	788 × 940 × 320	788 × 940 × 320	998 × 940 × 320	998 × 940 × 320	788 × 940 × 320	998 × 940 × 320	998 × 940 × 320
Weight	Indoor	kg	23	23	24	26	29	29	29	29	29	29
	Outdoor		36	38	42	52	52	67	67	53	67	67
Connection Pipe Diameter (Liquid/Gas)		mm	6.35/12.70	6.35/12.70	6.35/12.70	9.52/15.88	9.52/15.88	9.52/15.88	9.52/15.88	9.52/15.88	9.52/15.88	9.52/15.88
Drain Hose Diameter (I.D./O.D.)			25/32	25/32	25/32	25/32	25/32	25/32	25/32	25/32	25/32	25/32
Max. Pipe Length (Pre-Charge)		m	30 (20)	30 (20)	30 (20)	50 (30)	50 (30)	50 (30)	50 (30)	50 (30)	50 (30)	50 (30)
Max. Height Difference			20	25	25	30	30	30	30	30	30	30
Operating Range	Cooling	°CDB	-15 to 46	-15 to 46	-15 to 46	-15 to 46	-15 to 46	-15 to 46	-15 to 46	-15 to 46	-15 to 46	-15 to 46
	Heating		-15 to 24	-15 to 24	-15 to 24	-15 to 24	-15 to 24	-15 to 24	-15 to 24	-15 to 24	-15 to 24	-15 to 24
Refrigerant	Type (Global Warming Potential)		R32 (675)	R32 (675)	R32 (675)	R32 (675)	R32 (675)	R32 (675)	R32 (675)	R32 (675)	R32 (675)	R32 (675)
	Charge	kg (CO2eq-T)	1.02 (0.689)	1.25 (0.844)	1.25 (0.844)	1.90 (1.283)	1.90 (1.283)	2.70 (1.823)	2.70 (1.823)	1.90 (1.283)	2.70 (1.823)	2.70 (1.823)
Cassette Grille	Variation		UTG-UKYA-W: White wired remote controller (touch panel) UTG-UKYC-W: White/UTG-UKYA-B*: Black							UTG-UKYA-W: White wired remote controller (touch panel) UTG-UKYC-W: White/UTG-UKYA-B*: Black		
	Dimensions (H × W × D)	mm	53 × 950 × 950	53 × 950 × 950	53 × 950 × 950	53 × 950 × 950	53 × 950 × 950	53 × 950 × 950	53 × 950 × 950	53 × 950 × 950	53 × 950 × 950	53 × 950 × 950
	Weight	kg	6.0	6.0	6.0	6.0	6.0	6.0	6.0	6.0	6.0	6.0

*1: IR Receiver Kit and Occupancy Sensor Kit cannot be connected.

Optional parts

* For information on the compatibility of optional parts for Intesis products, please refer to the compatibility list at the end of the "Control system & Optional parts" chapter.

Wired Remote Controller (Design type):	UTY-RVRY	WLAN adapter:	UTY-TFSXZ1	Cassette Grille:	UTG-UKYA-W
Compact wired remote controller:	UTY-RCRYZ1		UTY-TFSXJ3		UTG-UKYA-B
Wired remote controller (touch panel):	UTY-RNRYZ6	External input and output PCB:	UTY-XCSX		UTG-UKYC-W
Wired remote controller:	UTY-RLRY	External input and output PCB box:	UTZ-GXRA	Network Converter for single split (DC power supply type):	UTY-VTGX
	UTY-RNNYM	Insulation Kit for high humidity:	UTZ-KXRA	Network Converter for single split (AC power supply type):	UTY-VTGV
	UTY-RVNYM	Fresh Air Intake Kit:	UTZ-VXRA	Silver Ion Filter:	UTD-HFRA
Simple remote controller (without operation mode):	UTY-RHRYZ1	Wide Panel:	UTG-AXXA-W	External Connect Kit:	UTY-XWZXZG
Simple remote controller:	UTY-RSRYZ1	Panel Spacer:	UTG-BKXA-W		
Occupancy Sensor Kit:	UTY-SHZXC	Air Outlet Shutter Plate:	UTR-YDZK	(Outdoor unit 30/36/45/54)	
IR receiver unit	UTY-LBTYC	External switch controller:	UTY-TERX	External Connect Kit:	UTY-XWZXZ3

Dimensions

(Unit: mm)

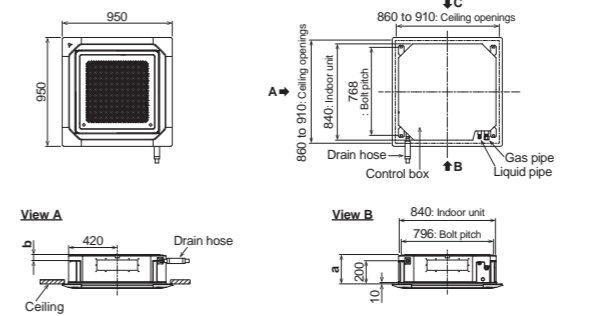

	AUXG 18/22/24KRLB	AUXG 30/36/45/54KRLB
a	256	298
b	56	98

Duct

Low Static Pressure Range

Slim Type
High ESP up to 90 Pa



Slim Design

The slim design fits nicely into narrow spaces under the ceiling. Drain hose as accessory



Compact and Lightweight Outdoor Unit

The compact and lightweight outdoor unit offers greater flexibility in the choice of installation location. This makes it easier to use this outdoor unit.



Wide Range of Static Pressures

The use of a DC fan motor makes it possible to adjust the static pressure between 0 and 90 Pa. The static pressure range can be changed by a remote controller.



Static pressure range
0 to 90 Pa

Auto Louver Grille Kit (Option)

The optional clean-looking flat Auto louver blends into any interior and provides a comfortable airflow.



Link Up with a Variety of Central Control System (Option)

Centralized control including facilities and equipment in addition to air conditioning is possible by linking up with MODBUS, KNX interfaces.



Model: ARXG09KLLAP / ARXG12KLLAP / ARXG14KLLAP / ARXG18KLLAP



ARXG09/12/14KLLAP



ARXG18KLLAP



For ARXG09/12/14KLLAP For ARXG18KLLAP

Specifications

Model name	Indoor unit		ARXG09KLLAP	ARXG12KLLAP	ARXG14KLLAP	ARXG18KLLAP
	Outdoor unit		AOEG09KBTB	AOEG12KBTB	AOEG14KBTB	AOEG18KBTB
Power Source	Single phase, ~230 V, 50 Hz					
Capacity	Cooling	Rated	2.5	3.5	4.3	5.2
		Min.-Max.	0.9-3.2	0.9-4.4	0.9-5.4	0.9-5.9
	Heating	Rated	3.2	4.1	5.0	6.0
Min.-Max.		0.9-4.7	0.9-5.7	0.9-6.5	0.9-7.5	
Input Power	Cooling/Heating	kW	0.60/0.79	0.93/1.08	1.28/1.32	1.55/1.62
EER	Cooling	W/W	4.17	3.76	3.36	3.35
COP	Heating	W/W	4.05	3.80	3.79	3.70
Pdesign	Cooling/Heating (-10°C)	kW	2.5/2.6	3.5/3.4	4.3/3.8	5.2/4.4
SEER	Cooling	W/W	6.20	6.10	5.80	6.20
SCOP	Heating	W/W	4.30	4.00	3.90	4.10
Energy Efficiency Class	Cooling		A++	A++	A+	A++
	Heating		A+	A+	A	A+
Max. Operating Current	Cooling/Heating	A	7.9/7.9	9.7/9.7	10.2/10.2	12.1/12.1
Annual Energy Consumption	Cooling	kWh/a	141	201	259	293
	Heating		845	1,189	1,362	1,501
Moisture Removal		l/h	0.7	1.3	1.5	2.0
Sound Pressure Level	Indoor (Cooling)	H/M/L/Q	28/27/26/25	29/28/26/25	32/30/28/26	32/30/29/27
	Indoor (Heating)	H/M/L/Q	28/26/25/24	29/28/26/24	32/30/28/25	32/30/29/27
Sound Power Level	Outdoor (Cooling/Heating)	High	46/46	47/47	49/49	50/50
	Indoor (Cooling/Heating)	High	57/57	58/58	60/60	58/58
Airflow Rate	Indoor/Outdoor (Cooling)	High	600/1,480	650/1,580	800/1,670	940/2,160
	Indoor/Outdoor (Heating)	High	600/1,410	650/1,520	800/1,580	940/1,830
Static pressure range (Standard)		Pa	0 to 90 (25)	0 to 90 (25)	0 to 90 (25)	0 to 90 (25)
Net Dimensions H x W x D	Indoor	mm	198 x 700 x 620	198 x 700 x 620	198 x 700 x 620	198 x 900 x 620
	Outdoor	mm	542 x 799 x 290	542 x 799 x 290	542 x 799 x 290	632 x 799 x 290
Weight	Indoor	kg	17	17	17	20
	Outdoor	kg	32	33	33	36
Connection Pipe Diameter (Liquid/Gas)		mm	6.35/9.52	6.35/9.52	6.35/9.52	6.35/12.70
Drain Hose Diameter (I.D./O.D.)		mm	25/32	25/32	25/32	25/32
Max. Pipe Length (Pre-Charge)		m	20 (15)	25 (15)	25 (15)	30 (20)
Max. Height Difference			15	20	20	20
Operating Range	Cooling	°CDB	-15 to 46	-15 to 46	-15 to 46	-15 to 46
	Heating		-15 to 24	-15 to 24	-15 to 24	-15 to 24
Refrigerant	Type (Global Warming Potential)		R32 (675)	R32 (675)	R32 (675)	R32 (675)
	Charge	kg (CO2eq-T)	0.85 (0.574)	0.85 (0.574)	0.85 (0.574)	1.02 (0.689)

Optional parts

* For information on the compatibility of optional parts for Intesis products, please refer to the compatibility list at the end of the "Control system & Optional parts" chapter.

Wired Remote Controller (Design type): UTY-RVRY	Simple remote controller: UTY-RSRYZ1	Network Converter for single split (DC power supply type): UTY-VTGX
Compact wired remote controller: UTY-RCRYZ1	WLAN adapter: UTY-TFSXZ1	Network Converter for single split (AC power supply type): UTY-VTGXV
Wired remote controller (touch panel): UTY-RNRYZ6	Silver Ion Filter: UTY-TFSXJ3	External connect Kit: UTY-XWZXZG
Wired remote controller: UTY-RLRY	UTD-HFTA (09-14)	Remote sensor unit: UTY-XSZZX1
UTY-RNNYM	UTD-HFTB (18)	Auto Louver Grille Kit: UTY-GXTA-W (09-14)
UTY-RVNYM	External switch controller: UTY-TERX	UTD-GXTB-W (18)
Simple remote controller (without operation mode): UTY-RHRYZ1	IR receiver unit: UTY-LBTYM	

Dimensions

(Unit: mm)

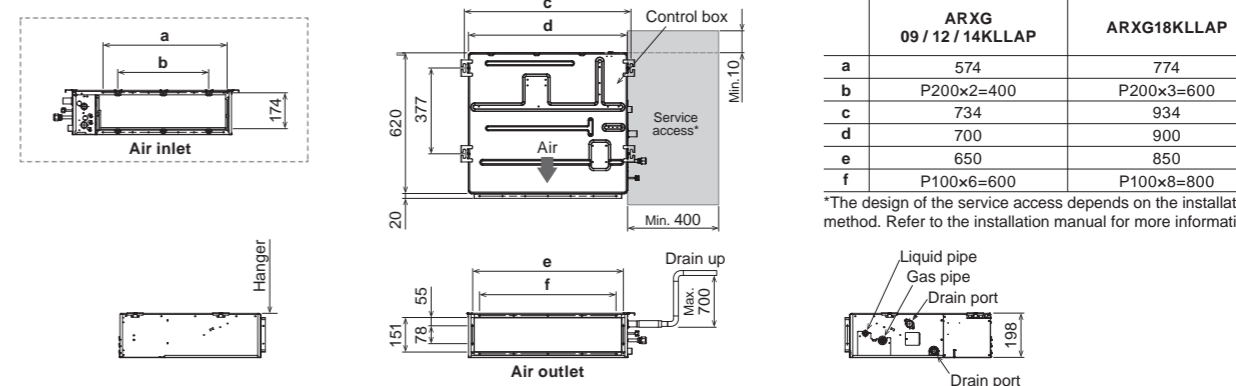

SPLIT

Duct
Medium Static Pressure Range
High-Efficiency & Comfort
ESP up to 150 Pa



Slim & Compact Design

The product has reduced the height to 240 mm, making it more compact. The slim design fits nicely into narrow spaces under the ceiling.

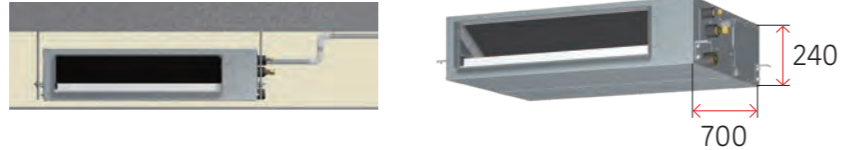

High Energy Saving

The model has achieved high energy efficiency class with a compact design.

Class Cooling A++ Heating A+

SEER 6.50^{*1} SCOP 4.20^{*2}

*1: 12/22 models *2: 12/22/24 models

Easy Maintenance

The indoor unit have large panels on both sides providing easy maintenance in narrow spaces.

- Easy inspection of drain hose**
The whole drain hose can be removed for easy replacement and cleaning.
- Easy cleaning of the heat exchanger**
- Filter change**
Filter can be installed and removed easily.
* Long life filter is available as optional parts.

Drain Hose as Standard

A drain hose is a accessory, making it easy to design ditch even in narrow spaces under the ceiling.



Wide Range of Static Pressures

Static pressures can be changed in the range of 30 to 150 Pa.

Static pressure range
30 to 150 Pa



Model: ARXH12KMTAP / ARXH14KMTAP / ARXH18KMTAP / ARXH22KMTAP / ARXH24KMTAP



For ARXH12/14KMTAP For ARXH18/22KMTAP For ARXH24KMTAP

Specifications

Model name	Indoor unit		ARXH12KMTAP	ARXH14KMTAP	ARXH18KMTAP	ARXH22KMTAP	ARXH24KMTAP
	Outdoor unit		AOEG12KBTB	AOEG14KBTB	AOEG18KBTB	AOEG22KBTB	AOEG24KBTB
Power Source			Single phase, ~230 V, 50 Hz				
Capacity	Cooling	Rated	3.5	4.3	5.2	6.0	6.8
		Min.-Max.	0.9-4.4	0.9-5.4	0.9-5.9	0.9-6.7	0.9-8.0
	Heating	Rated	4.1	5.0	6.0	7.0	7.5
Min.-Max.		0.9-5.7	0.9-6.5	0.9-7.5	0.9-8.0	0.9-9.1	
Input Power	Cooling/Heating	kW	0.930 / 1.080	1.260 / 1.320	1.580 / 1.740	1.67 / 1.84	1.89 / 1.87
EER	Cooling	W/W	3.76	3.40	3.30	3.60	3.60
COP	Heating	W/W	3.80	3.79	3.45	3.80	4.01
Pdesign	Cooling/Heating (-10°C)	kW	3.5 / 3.4	4.3 / 3.8	5.2 / 4.4	6.0 / 4.8	6.8 / 6.0
SEER	Cooling	W/W	6.50	6.10	6.20	6.50	6.40
SCOP	Heating (Average)	W/W	4.20	4.00	4.10	4.20	4.20
Energy Efficiency Class	Cooling		A++	A++	A++	A++	A++
	Heating (Average)		A+	A+	A+	A+	A+
Max. Operating Current	Cooling/Heating	A	9.7 / 9.7	10.2 / 10.2	12.1 / 12.1	12.6 / 12.6	13.6 / 13.6
Annual Energy Consumption	Cooling	kWh/a	196	255	301	331	380
	Heating	kWh/a	1,133	1,330	1,501	1,598	1,999
Moisture Removal		l/h	1.3	1.3	2.0	1.5	2.2
Sound Pressure Level	Indoor (Cooling)	H/M/L/Q	29 / 27 / 25 / 23	32 / 29 / 27 / 25	33 / 30 / 28 / 26	32 / 28 / 25 / 24	34 / 30 / 28 / 26
	Indoor (Heating)	H/M/L/Q	29 / 27 / 25 / 23	32 / 29 / 27 / 25	33 / 30 / 28 / 26	32 / 28 / 25 / 24	34 / 30 / 28 / 26
	Outdoor (Cooling/Heating)	High	47 / 47	49 / 49	50 / 50	51 / 51	53 / 54
Sound Power Level	Indoor (Cooling/Heating)	High	58 / 58	59 / 59	60 / 60	58 / 58	60 / 60
	Outdoor (Cooling/Heating)	High	61 / 61	62 / 62	62 / 62	63 / 63	65 / 66
	Indoor/Outdoor (Cooling)	High	650 / 1,580	800 / 1,670	840 / 2,160	1,150 / 2,240	1,230 / 2,700
Airflow Rate	Indoor/Outdoor (Heating)	High	650 / 1,520	800 / 1,580	840 / 1,830	1,150 / 1,960	1,230 / 2,700
Static pressure range (Standard)		Pa	30 to 150 (40)	30 to 150 (40)	30 to 150 (40)	30 to 150 (40)	30 to 150 (50)
Net Dimensions	Indoor	mm	240 × 700 × 700	240 × 700 × 700	240 × 700 × 700	240 × 1,000 × 700	240 × 1,000 × 700
	Outdoor	mm	542 × 799 × 290	542 × 799 × 290	632 × 799 × 290	632 × 799 × 290	716 × 820 × 315
Weight	Indoor	kg	24	24	24	31	31
	Outdoor	kg	33	33	36	38	42
Connection Pipe Diameter (Liquid/Gas)		mm	6.35 / 9.52	6.35 / 9.52	6.35 / 12.7	6.35 / 12.70	6.35 / 12.70
Drain Hose Diameter (I.D./O.D.)		mm	25 / 32	25 / 32	25 / 32	25 / 32	25 / 32
Max. Pipe Length (Pre-Charge)		m	25 (15)	25 (15)	30 (20)	30 (20)	30 (20)
Max. Height Difference			20	20	20	25	25
Operating Range	Cooling	°CDB	-15 to 46	-15 to 46	-15 to 46	-15 to 46	-15 to 46
	Heating	°CDB	-15 to 24	-15 to 24	-15 to 24	-15 to 24	-15 to 24
Refrigerant	Type (Global Warming Potential)		R32 (675)	R32 (675)	R32 (675)	R32 (675)	R32 (675)
	Charge	kg (CO2eq-T)	0.85 (0.574)	0.85 (0.574)	1.02 (0.689)	1.25 (0.844)	1.25 (0.844)

Optional parts

* For information on the compatibility of optional parts for Intesis products, please refer to the compatibility list at the end of the "Control system & Optional parts" chapter.

Wired Remote Controller (Design type): UTY-RVRY	Silver ion filter: UTD-HFNC (12/14/18)	External input and output PCB: UTY-XCSX
Compact wired remote controller: UTY-RCRYZ1	UTD-HFNB (22/24)	External input and output PCB bracket: UTY-GXDA
Wired remote controller (touch panel): UTY-RNRYZ6	Long-life filter: UTD-LFDC (12/14/18)	Network Converter for single split (DC power supply type): UTY-VTGX
Wired remote controller: UTY-RLRY	UTD-LFDB (22/24)	Network Converter for single split (AC power supply type): UTY-VTGXV
Simple remote controller (without operation mode): UTY-RHRYZ1	MODBUS converter: UTY-VMSX	External Connect Kit: UTY-XWZXZG
Simple remote controller: UTY-RSRYZ1	KNX converter: UTY-VKXS	IR receiver unit: UTY-LBTYM
Remote sensor unit: UTY-XSZX	WLAN adapter: UTY-TFSXZ1	External switch controller: UTY-TERX
	UTY-XSZXZ1	

Dimensions

(Unit: mm)

	ARXH 12 / 14 / 18 KMTAP	ARXH 22 / 24 KMTAP
a	650	895
b	740	1,040
c	P100 × 5 = 500	P100 × 8 = 800
d	P100 × 5 = 500	P100 × 7 = 700
e	700	1,000
f	490	790

*The design of the service access depends on the installation method. Refer to the installation manual for more information.

Duct
Medium Static Pressure Range
High-Efficiency & Comfort
ESP up to 150 Pa



Model: ARXH30KMTAP / ARXH36KMTAP / ARXH45KMTAP / ARXH54KMTAP
ARXH36KMTAP [3-phase] / ARXH45KMTAP [3-phase] / ARXH54KMTAP [3-phase]

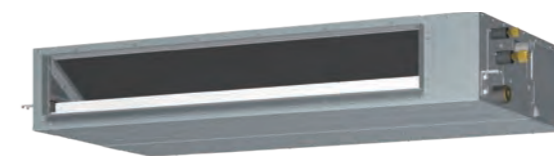

For ARXH30/36KMTAP For ARXH45/54KMTAP

Specifications

Model name	Indoor unit			ARXH30KMTAP	ARXH36KMTAP	ARXH45KMTAP	ARXH36KMTAP	ARXH45KMTAP	ARXH54KMTAP
	Outdoor unit			AOEG30KBTB	AOEG36KBTB	AOEG45KBTB	AOEG36KRTA	AOEG45KRTA	AOEG54KRTA
Power Source	Single phase, ~230 V, 50 Hz						3-phase, ~400 V, 50 Hz		
Capacity	Cooling	Rated	kW	8.5	9.5	12.1	9.5	12.1	13.4
		Min.-Max.		2.8-10.0	2.8-11.2	4.0-13.5	2.8-11.2	4.0-13.5	4.5-14.5
	Heating	Rated	10.0	10.8	13.5	10.8	13.5	15.5	
		Min.-Max.		2.7-11.2	2.7-12.7	4.2-16.2	2.7-12.7	4.2-16.2	4.7-16.5
Input Power	Cooling/Heating		kW	2.57 / 2.50	2.97 / 2.70	3.87 / 3.73	2.97 / 2.70	3.87 / 3.73	4.62 / 4.65
EER	Cooling		W/W	3.31	3.20	3.13	3.20	3.13	2.90
COP	Heating		W/W	4.00	4.00	3.62	4.00	3.62	3.33
Pdesign	Cooling/Heating (-10°C)		kW	8.5 / 8.0	9.5 / 8.7	12.1 / 9.2	9.5 / 8.7	12.1 / 9.2	13.4 / 9.5
SEER	Cooling		W/W	6.23	6.10	5.60	6.10	5.60	5.41
SCOP	Heating (Average)		W/W	4.00	4.10	4.10	4.10	4.10	4.10
Energy Efficiency Class	Cooling			A++	A++	-	A++	-	-
	Heating (Average)			A+	A+	-	A+	-	-
ηc			%	-	-	221.0	-	221.0	213.4
ηh			%	-	-	161.0	-	161.0	161.0
Max. Operating Current	Cooling/Heating		A	22.6 / 22.6	22.6 / 22.6	28.5 / 28.5	10.5 / 10.5	14.0 / 14.0	14.0 / 14.0
Annual Energy Consumption	Cooling		kWh/a	485	553	-	553	-	-
	Heating		kWh/a	2,795	2,970	-	2,970	-	-
Moisture Removal			l/h	1.8	2.0	4.0	2.0	4.0	5.0
Sound Pressure Level	Indoor (Cooling)	H/M/L/Q	dB(A)	38 / 34 / 31 / 28	38 / 34 / 31 / 28	40 / 36 / 32 / 29	38 / 34 / 31 / 28	40 / 36 / 32 / 29	40 / 36 / 32 / 29
	Indoor (Heating)	H/M/L/Q		38 / 34 / 31 / 28	38 / 34 / 31 / 28	40 / 36 / 32 / 29	38 / 34 / 31 / 28	40 / 36 / 32 / 29	40 / 36 / 32 / 29
Sound Power Level	Outdoor (Cooling/Heating)	High	dB(A)	53 / 55	55 / 55	57 / 57	55 / 55	57 / 57	57 / 59
	Indoor (Cooling/Heating)	High		64 / 64	65 / 65	67 / 67	65 / 65	67 / 67	67 / 67
Airflow Rate	Indoor/Outdoor (Cooling)	High	m³/h	1,950 / 3,750	2,070 / 3,750	2,160 / 4,450	2,070 / 3,750	2,160 / 4,450	2,160 / 4,450
	Indoor/Outdoor (Heating)	High		1,950 / 3,750	2,070 / 3,750	2,160 / 4,450	2,070 / 3,750	2,160 / 4,450	2,160 / 4,450
Static pressure range (Standard)			Pa	30 to 150 (50)	30 to 150 (50)	30 to 150 (60)	30 to 150 (50)	30 to 150 (60)	30 to 150 (60)
Net Dimensions H x W x D	Indoor	mm	240 × 1,400 × 700	240 × 1,400 × 700	240 × 1,400 × 700	240 × 1,400 × 700	240 × 1,400 × 700	240 × 1,400 × 700	240 × 1,400 × 700
	Outdoor	mm	788 × 940 × 320	788 × 940 × 320	998 × 940 × 320	788 × 940 × 320	998 × 940 × 320	998 × 940 × 320	998 × 940 × 320
Weight	Indoor	kg	42	42	42	42	42	42	42
	Outdoor	kg	52	52	67	53	67	67	
Connection Pipe Diameter (Liquid/Gas)			mm	9.52 / 15.88	9.52 / 15.88	9.52 / 15.88	9.52/15.88	9.52/15.88	9.52/15.88
Drain Hose Diameter (I.D./O.D.)			mm	25 / 32	25 / 32	25 / 32	25/32	25/32	25/32
Max. Pipe Length (Pre-Charge)			m	50 (30)	50 (30)	50 (30)	50 (30)	50 (30)	50 (30)
Max. Height Difference			m	30	30	30	30	30	30
Operating Range	Cooling	°CDB	-15 to 46	-15 to 46	-15 to 46	-15 to 46	-15 to 46	-15 to 46	-15 to 46
	Heating	°CDB	-15 to 24	-15 to 24	-15 to 24	-15 to 24	-15 to 24	-15 to 24	-15 to 24
Refrigerant	Type (Global Warming Potential)		R32 (675)	R32 (675)	R32 (675)	R32 (675)	R32 (675)	R32 (675)	R32 (675)
	Charge	kg (CO2eq-T)	1.90 (1.283)	1.90 (1.283)	2.70 (1.823)	1.90 (1.283)	2.70 (1.823)	2.70 (1.823)	

Slim & Compact Design

The product has reduced the height to 240 mm, making it more compact. The slim design fits nicely into narrow spaces under the ceiling.



High Energy Saving

The model has achieved high energy efficiency class with a compact design.

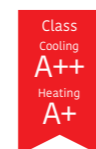

SEER **6.23**^{*1} SCOP **4.10**^{*2}

*1: 30 model *2: 36 model

Easy Maintenance

The indoor units have large panels on both sides providing easy maintenance in narrow spaces.



Drain Hose as Standard

A drain hose is a accessory, making it easy to design ditch even in narrow spaces under the ceiling.



Wide Range of Static Pressures

Static pressures can be changed in the range of 30 to 150 Pa.

Static pressure range **30 to 150 Pa**

Optional parts

* For information on the compatibility of optional parts for Intesis products, please refer to the compatibility list at the end of the "Control system & Optional parts" chapter.

Wired Remote Controller (Design type):	UTY-RVRY	IR receiver unit:	UTY-LBTYM	External input and output PCB:	UTY-XCSX
Compact wired remote controller:	UTY-RCRYZ1	Silver ion filter:	UTD-HFNA	External input and output PCB bracket:	UTZ-GXDA
Wired remote controller (touch panel):	UTY-RNRYZ6	Long-life filter:	UTD-LFDA	Network Converter for single split (DC power supply type):	UTY-VTGX
Wired remote controller:	UTY-RLRY	MODBUS converter:	UTY-VMSX	Network Converter for single split (AC power supply type):	UTY-VTGXV
Simple remote controller (without operation mode):	UTY-RHRYZ1	KNX converter:	UTY-VKSX	External Connect Kit:	UTY-XWZXG
Simple remote controller:	UTY-RSRYZ1	WLAN adapter:	UTY-TFSXZ1	(Outdoor unit)	
Remote sensor unit:	UTY-XSZX	External switch controller:	UTY-TFSXJ3	External Connect Kit:	UTY-XWZXZ3
	UTY-XSZXZ1				

Dimensions

(Unit: mm)

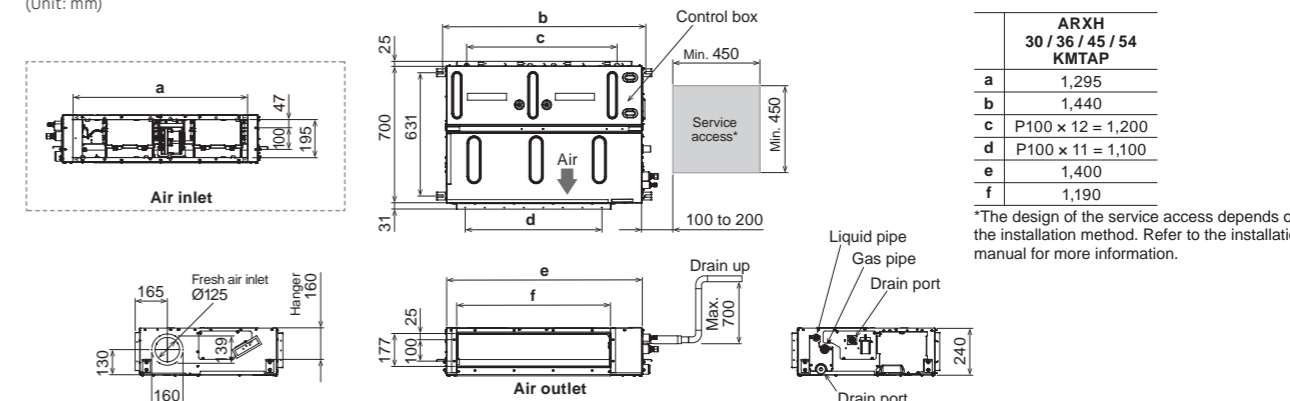

ARXH 30 / 36 / 45 / 54 KMTAP	
a	1,295
b	1,440
c	P100 × 12 = 1,200
d	P100 × 11 = 1,100
e	1,400
f	1,190

*The design of the service access depends on the installation method. Refer to the installation manual for more information.

Duct
Medium Static
Pressure Range
Standard
ESP up to 150 Pa

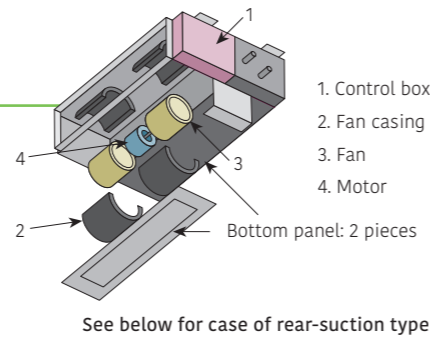

Easy Maintenance

Structural improvement is attained by making the bottom panel in two pieces—front and rear. The internal fan casing is also manufactured in two pieces—upper and lower. As a result, the motor and fan can be easily accessed and maintained by removing the rear panel and the lower casing while leaving the main chassis in place.

Slim & Compact Design

Indoor Unit
The slim and compact design of the indoor unit, with the control box mounted on the side, allows installation in narrow spaces.

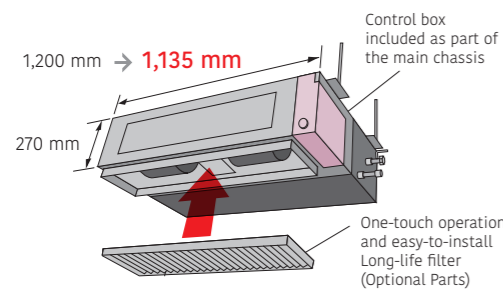

Outdoor Unit

The outdoor units for the 45,000 BTU and 54,000 BTU models have been completely redesigned. Easier installation is achieved for this compact and lightweight outdoor unit.

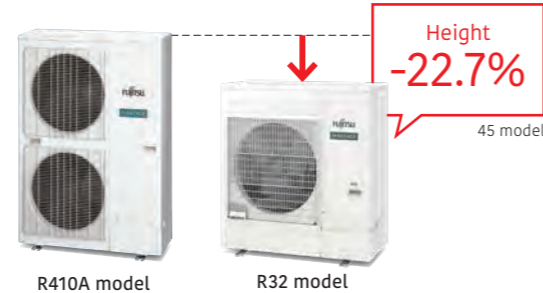

Two-Direction Drain Pipe

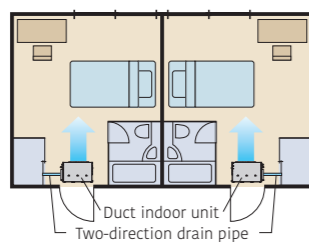

Link Up with a Variety of Central Control System (Option)

Centralized control including facilities and equipment in addition to air conditioning is possible by linking up with MODBUS, KNX interfaces.



Model: ARXG22KMLB / ARXG24KMLA / ARXG30KMLA / ARXG36KMLA / ARXG45KMLA / ARXG36KMLA [3-phase] / ARXG45KMLA [3-phase]



Specifications

Model name	Indoor unit		ARXG22KMLB	ARXG24KMLA	ARXG30KMLA	ARXG36KMLA	ARXG45KMLA	ARXG36KMLA	ARXG45KMLA
	Outdoor unit		AOEG22KBTB	AOEG24KBTB	AOEG30KBTB	AOEG36KBTB	AOEG45KBTB	AOEG36KRTA	AOEG45KRTA
Power Source	Single phase, ~230 V, 50 Hz							3-phase, ~400 V, 50 Hz	
Capacity	Cooling	Rated	6.0	6.8	8.5	9.5	12.1	9.5	12.1
		Min.-Max.	0.9-6.7	0.9-8.0	2.8-10.0	2.8-11.2	4.0-13.0	2.8-11.2	4.0-13.0
	Heating	Rated	7.0	7.5	10.0	10.8	13.5	10.8	13.5
Input Power	Cooling/Heating	Min.-Max.	0.9-8.0	0.9-9.1	2.7-11.2	2.7-12.7	4.2-15.2	2.7-12.7	4.2-15.2
		Rated	1.78/1.87	2.14/1.97	2.65/2.63	2.97/2.88	4.22/3.84	2.97/2.88	4.22/3.84
EER	Cooling	W/W	3.37	3.18	3.21	3.20	2.87	3.20	2.87
COP	Heating	W/W	3.74	3.80	3.80	3.75	3.52	3.75	3.52
Pdesign	Cooling/Heating (-10°C)	kW	6.0/4.8	6.8/6.0	8.5/8.0	9.5/8.7	12.1/9.2	9.5/8.7	12.1/9.2
SEER	Cooling	W/W	6.10	6.20	6.23	6.10	5.25	6.10	5.25
SCOP	Heating	W/W	4.10	4.10	4.00	4.00	3.63	4.00	3.63
Energy Efficiency Class	Cooling		A++	A++	A++	A++	-	A++	-
	Heating		A+	A+	A+	A+	-	A+	-
ηc		%	-	-	-	-	207.0	-	207.0
ηh		%	-	-	-	-	142.2	-	142.2
Max. Operating Current	Cooling/Heating	A	12.6/12.6	13.6/13.6	22.6/22.6	22.6/22.6	28.5/28.5	10.5/10.5	14.0/14.0
	Cooling	kWh/a	344	384	477	545	-	545	-
Annual Energy Consumption	Cooling	kWh/a	1,637	2,045	2,797	3,044	-	3,044	-
	Heating	kWh/a	2.1	2.5	2.5	3.0	4.0	3.0	4.0
Moisture Removal	Indoor (Cooling)	H/M/L/Q	31/29/27/25	31/29/27/25	39/35/30/26	39/35/30/26	42/38/32/28	39/35/30/26	42/38/32/28
	Indoor (Heating)	H/M/L/Q	31/29/27/25	31/29/27/25	42/35/30/26	42/35/30/26	42/38/32/28	42/35/30/26	42/38/32/28
Sound Pressure Level	Outdoor (Cooling/Heating)	High	51/51	53/54	53/55	55/55	57/57	55/55	57/57
	Indoor (Cooling/Heating)	High	60/62	60/62	65/69	65/70	68/70	65/70	68/70
Sound Power Level	Outdoor (Cooling/Heating)	High	63/63	65/66	68/69	70/70	71/71	70/70	71/71
	Indoor (Cooling/Heating)	High	1,100/2,240	1,100/2,700	1,900/3,750	1,900/3,750	2,100/4,450	1,900/3,750	2,100/4,450
Airflow Rate	Indoor/Outdoor (Cooling)	High	1,100/1,960	1,100/2,700	2,100/3,750	2,100/3,750	2,100/4,450	2,100/3,750	2,100/4,450
	Indoor/Outdoor (Heating)	High	30 to 150 (35)	30 to 150 (35)	30 to 150 (47)	30 to 150 (47)	30 to 150 (60)	30-150 (47)	30-150 (60)
Static pressure range (Standard)		Pa	270 × 1,135 × 700	270 × 1,135 × 700	270 × 1,135 × 700	270 × 1,135 × 700	270 × 1,135 × 700	270 × 1,135 × 700	270 × 1,135 × 700
Net Dimensions H x W x D	Indoor	mm	632 × 799 × 290	716 × 820 × 315	788 × 940 × 320	788 × 940 × 320	998 × 940 × 320	788 × 940 × 320	998 × 940 × 320
	Outdoor	mm	35	38	52	52	67	53	67
Weight	Indoor	kg	38	42	52	52	67	53	67
	Outdoor	kg	6.35/12.70	6.35/12.70	9.52/15.88	9.52/15.88	9.52/15.88	9.52/15.88	9.52/15.88
Connection Pipe Diameter (Liquid/Gas)		mm	35.7/38.1	35.7/38.1	35.7/38.1	35.7/38.1	35.7/38.1	35.7/38.1	
Drain Hose Diameter (I.D./O.D.)		mm	30 (20)	30 (20)	50 (30)	50 (30)	50 (30)	50 (30)	
Max. Pipe Length (Pre-Charge)		m	25	25	30	30	30	30	
Max. Height Difference	Cooling	°CDB	-15 to 46	-15 to 46	-15 to 46	-15 to 46	-15 to 46	-15 to 46	
	Heating	°CDB	-15 to 24	-15 to 24	-15 to 24	-15 to 24	-15 to 24	-15 to 24	
Refrigerant	Type (Global Warming Potential)		R32 (675)	R32 (675)	R32 (675)	R32 (675)	R32 (675)	R32 (675)	
	Charge	kg (CO2eq-T)	1.25 (0.844)	1.25 (0.844)	1.90 (1.283)	1.90 (1.283)	2.70 (1.823)	1.90 (1.283)	2.70 (1.823)

Optional parts

* For information on the compatibility of optional parts for Intesis products, please refer to the compatibility list at the end of the "Control system & Optional parts" chapter.

Wired Remote Controller (Design type):	UTY-RVRY	WLAN adapter:	UTY-TFSXZ1	Network Converter for single split (DC power supply type):	UTY-VTGX
Compact wired remote controller:	UTY-RCRYZ1		UTY-TFSXJ3	Network Converter for single split (AC power supply type):	UTY-VTGXV
Wired remote controller (touch panel):	UTY-RNRYZ6	Flange (Round):	UTD-RF204	Long-life filter:	UTD-LF25NA
Wired remote controller:	UTY-RLRY	Flange (Square):	UTD-SF045T	Silver Ion Filter:	UTD-HFND
	UTY-RNNYM	IR receiver unit:	UTY-LBTYM	External Connect Kit:	UTY-XWZXZG
	UTY-RVNYM	Remote sensor unit:	UTY-XSZXZ1		
Simple remote controller (without operation mode):	UTY-RHRYZ1	Drain pump unit:	UTZ-PX1NBA	(Outdoor unit 30/36/45)	
Simple remote controller:	UTY-RSRYZ1	External switch controller:	UTY-TERX	External Connect Kit:	UTY-XWZXZ3

Dimensions

(Unit: mm)

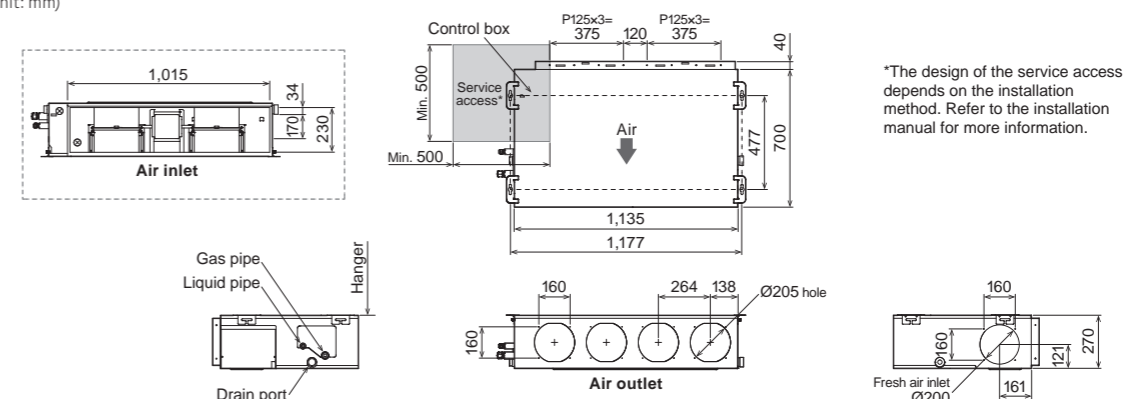

*The design of the service access depends on the installation method. Refer to the installation manual for more information.

Duct
High Static Pressure Range
Compact Size
ESP up to 200 Pa



High-Efficiency & Quiet Operation

The combination of the V-shaped heat exchanger, air stabilizer, and the high-efficiency DC fan motor enable high-efficiency and quiet operation.

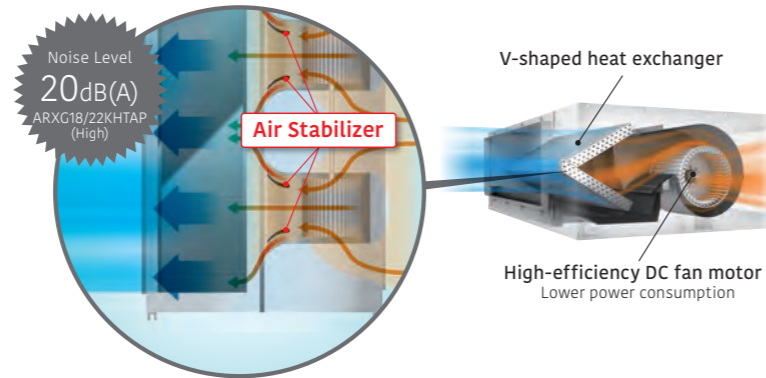

Small Lightweight Outdoor Unit

The outdoor unit in this series is smaller and lighter than previous-generation outdoor units. It can be installed in a narrow space.



Automatic Airflow Adjustment Function

This unique and innovative function detects required air flow in each application case and automatically adjust the volume.

Static pressure automatically adjust !



Link Up with a Variety of Central Control System (Option)

Centralized control including facilities and equipment in addition to air conditioning is possible by linking up with MODBUS, KNX interfaces.



Model: ARXG12KHTAP / ARXG14KHTAP / ARXG18KHTAP / ARXG22KHTAP / ARXG24KHTAP / ARXG30KHTAP



Specifications

Model name	Indoor unit		ARXG12KHTAP	ARXG14KHTAP	ARXG18KHTAP	ARXG22KHTAP	ARXG24KHTAP	ARXG30KHTAP
	Outdoor unit		AOEG12KBTB	AOEG14KBTB	AOEG18KBTB	AOEG22KBTB	AOEG24KBTB	AOEG30KBTB
Power Source	Single phase, ~230 V, 50 Hz							
Capacity	Cooling	Rated	3.5	4.3	5.2	6.0	6.8	8.5
		Min.-Max.	0.9-4.4	0.9-5.4	0.9-5.9	0.9-6.7	0.9-8.0	2.8-10.0
	Heating	Rated	4.1	5.0	6.0	7.0	7.5	10.0
Min.-Max.		0.9-5.7	0.9-6.5	0.9-7.5	0.9-8.0	0.9-9.1	2.7-11.2	
Input Power	Cooling/Heating	kW	0.87/1.00	1.17/1.25	1.36/1.56	1.71/1.81	1.89/1.85	2.65/2.63
EER	Cooling	W/W	4.02	3.68	3.82	3.51	3.60	3.21
COP	Heating	W/W	4.10	4.00	3.85	3.87	4.06	3.80
Pdesign	Cooling/Heating (-10°C)	kW	3.5/3.4	4.3/3.8	5.2/4.4	6.0/4.8	6.8/6.0	8.5/8.0
SEER	Cooling	W/W	6.30	6.20	6.50	6.50	6.50	6.23
SCOP	Heating (Average)	W/W	4.10	4.00	4.10	4.20	4.10	4.00
Energy Efficiency Class	Cooling		A++	A++	A++	A++	A++	A++
	Heating (Average)		A+	A+	A+	A+	A+	A+
Max. Operating Current	Cooling/Heating	A	9.7/9.7	10.2/10.2	12.1/12.1	12.6/12.6	13.6/13.6	22.6/22.6
Annual Energy Consumption	Cooling	kWh/a	194	243	280	323	366	477
	Heating	kWh/a	1,159	1,328	1,501	1,597	2,048	2,796
Moisture Removal		l/h	0.7	0.9	1.2	1.5	1.8	2.3
Sound Pressure Level	Indoor (Cooling)	H/M/L/Q	32/27/26/24	33/28/27/25	28/25/22/20	28/25/22/20	32/28/24/21	36/33/30/29
	Indoor (Heating)	H/M/L/Q	32/27/26/24	33/28/27/25	28/25/22/20	28/25/22/20	32/28/24/21	36/33/30/29
	Outdoor (Cooling/Heating)	High	47/47	49/49	50/50	51/51	53/54	53/55
Sound Power Level	Indoor (Cooling/Heating)	High	57/58	59/60	54/54	57/57	57/57	63/65
	Outdoor (Cooling/Heating)	High	61/61	62/62	62/62	63/63	65/66	68/69
	Indoor/Outdoor (Cooling)	High	850/1,580	950/1,670	1,050/2,160	1,050/2,240	1,360/2,700	1,700/3,750
Airflow Rate	Indoor/Outdoor (Heating)	High	850/1,520	950/1,580	1,050/1,830	1,050/1,960	1,360/2,700	1,700/3,750
Static pressure range (Standard)		Pa	30 to 200 (35)	30 to 200 (35)	30 to 200 (35)	30 to 200 (35)	30 to 200 (35)	30 to 200 (47)
Net Dimensions	Indoor	mm	300 × 700 × 700	300 × 700 × 700	300 × 1,000 × 700	300 × 1,000 × 700	300 × 1,000 × 700	300 × 1,000 × 700
	Outdoor	mm	542 × 799 × 290	542 × 799 × 290	632 × 799 × 290	632 × 799 × 290	716 × 820 × 315	788 × 940 × 320
Weight	Indoor	kg	27	27	35	35	36	36
	Outdoor	kg	33	33	36	38	42	52
Connection Pipe Diameter (Liquid/Gas)		mm	6.35/9.52	6.35/9.52	6.35/12.70	6.35/12.70	6.35/12.70	9.52/15.88
Drain Hose Diameter (I.D./O.D.)		mm	25/32	25/32	25/32	25/32	25/32	25/32
Max. Pipe Length (Pre-Charge)		m	25 (15)	25 (15)	30 (20)	30 (20)	30 (20)	50 (30)
Max. Height Difference	Cooling		20	20	20	25	25	30
	Heating		-15 to 46	-15 to 46	-15 to 46	-15 to 24	-15 to 24	-15 to 24
Operating Range	Cooling	°CDB	-15 to 46	-15 to 46	-15 to 46	-15 to 46	-15 to 46	-15 to 46
	Heating	°CDB	-15 to 24	-15 to 24	-15 to 24	-15 to 24	-15 to 24	-15 to 24
Refrigerant	Type (Global Warming Potential)		R32 (675)	R32 (675)	R32 (675)	R32 (675)	R32 (675)	R32 (675)
	Charge	kg (CO2eq-T)	0.85 (0.574)	0.85 (0.574)	1.02 (0.689)	1.25 (0.844)	1.25 (0.844)	1.90 (1.283)

Optional parts

* For information on the compatibility of optional parts for Intesis products, please refer to the compatibility list at the end of the "Control system & Optional parts" chapter.

Wired Remote Controller (Design type):	UTY-RVRY	Long-life filter:	UTD-LFNB (18-30)	External input and output PCB:	UTY-XCSX
Compact wired remote controller:	UTY-RCRYZ1	Silver Ion Filter:	UTD-LFNC (12-14)	External input and output PCB bracket:	UTZ-GXNA
Wired remote controller (touch panel):	UTY-RNRYZ6	WLAN adapter:	UTD-HFNB (18-30)	Network Converter for single split (DC power supply type):	UTY-VTGX
Wired remote controller:	UTY-RLRY		UTD-HFNC (12/14)	Network Converter for single split (AC power supply type):	UTY-VTGXV
	UTY-RNNYM		UTY-TFSXZ1		
	UTY-RVNYM		UTY-TFSXJ3	(Outdoor unit 30)	
Simple remote controller (without operation mode):	UTY-RHRYZ1	IR receiver unit:	UTY-LBTYM	External Connect Kit:	UTY-XWZXZ3
Simple remote controller:	UTY-RSRYZ1	External switch controller:	UTY-TERX		
Remote sensor unit:	UTY-XSZXZ1	External Connect Kit:	UTY-XWZXZG		

Dimensions

(Unit: mm)

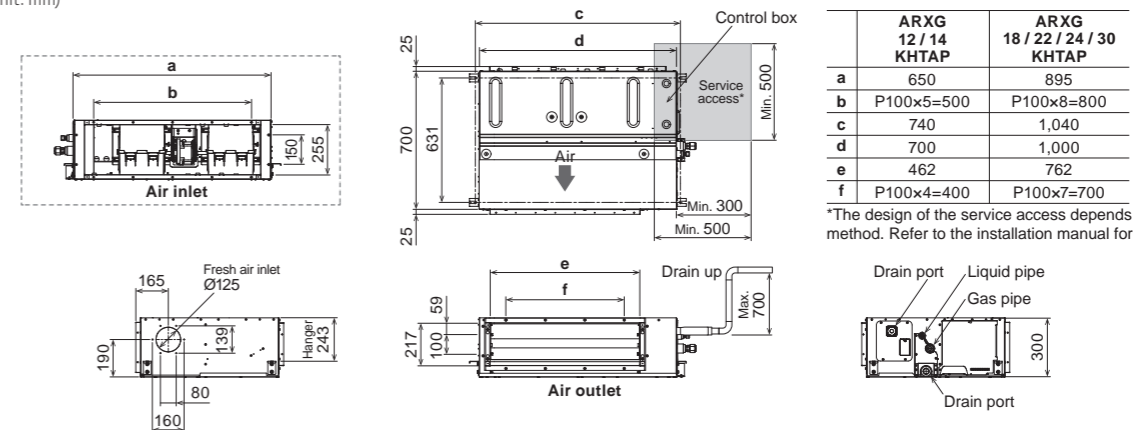

*The design of the service access depends on the installation method. Refer to the installation manual for more information.

Duct
High Static Pressure Range
Compact Size
ESP up to 200 Pa



(36/45/54)

High-Efficiency & Quiet Operation

The combination of the V-shaped heat exchanger, air stabilizer, and the high-efficiency DC fan motor enable high-efficiency and quiet operation.

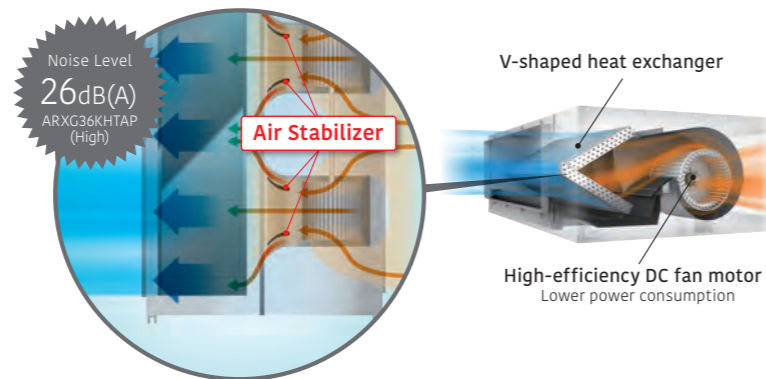

Small Lightweight Outdoor Unit

The outdoor unit in this series is smaller and lighter than previous-generation outdoor units. It can be installed in a narrow space.

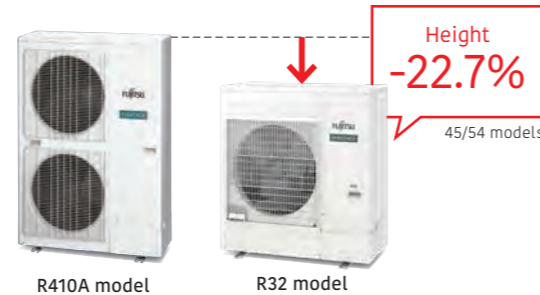

Automatic Airflow Adjustment Function

This unique and innovative function detects required air flow in each application case and automatically adjust the volume.

Static pressure automatically adjust !



Link Up with a Variety of Central Control System (Option)

Centralized control including facilities and equipment in addition to air conditioning is possible by linking up with MODBUS, KNX interfaces.



Model: ARXG36KHTAP / ARXG45KHTAP / ARXG54KHTAP
ARXG36KHTAP [3-phase] / ARXG45KHTAP [3-phase] / ARXG54KHTAP [3-phase]

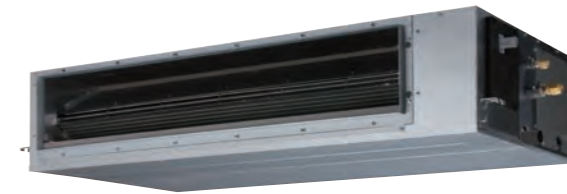

Specifications

Model name	Indoor unit			Outdoor unit				
	ARXG36KHTAP	ARXG45KHTAP	ARXG54KHTAP	AOEG36KRTA	AOEG45KRTA	AOEG54KRTA		
Power Source	Single phase, ~230 V, 50 Hz			3-phase, ~400 V, 50 Hz				
Capacity	Cooling	Rated	9.5	12.1	13.4	9.5	12.1	13.4
		Min.-Max.	2.8-11.2	4.0-14.0	4.5-14.5	2.8-11.2	4.0-14.0	4.5-14.5
	Heating	Rated	10.8	13.5	15.5	10.8	13.5	15.5
Input Power	Cooling/Heating	Min.-Max.	2.7-12.7	4.2-16.2	4.7-16.5	2.7-12.7	4.2-16.2	4.7-16.5
		Rated	2.86/2.48	3.53/3.37	4.42/3.89	2.86/2.48	3.53/3.37	4.42/3.89
EER	Cooling	W/W	3.32	3.43	3.03	3.32	3.43	3.03
COP	Heating	W/W	4.35	4.01	3.98	4.35	4.01	3.98
Pdesign	Cooling/Heating (-10°C)	kW	9.5 / 8.7	12.1 / 9.2	13.4 / 9.5	9.5 / 8.7	12.1 / 9.2	13.4 / 9.5
SEER	Cooling	W/W	6.10	5.83	5.81	6.10	5.83	5.81
SCOP	Heating (Average)	W/W	4.20	3.87	3.85	4.20	3.87	3.85
Energy Efficiency Class	Cooling		A++	-	-	A++	-	-
	Heating (Average)		A+	-	-	A+	-	-
ηc		%	-	230.2	229.4	-	230.2	229.4
ηh		%	-	151.8	151.0	-	151.8	151.0
Max. Operating Current	Cooling/Heating	A	22.6/22.6	28.5/28.5	28.5/28.5	10.5/10.5	14.0/14.0	14.0/14.0
Annual Energy Consumption	Cooling	kWh/a	544	-	-	544	-	-
	Heating	kWh/a	2,898	-	-	2,898	-	-
Moisture Removal		l/h	2.0	2.6	3.7	2.0	2.6	3.7
Sound Pressure Level	Indoor (Cooling)	H/M/L/Q	36/31/28/26	39/35/31/29	39/35/31/29	36/31/28/26	39/35/31/29	39/35/31/29
	Indoor (Heating)	H/M/L/Q	33/31/28/26	39/35/31/29	39/35/31/29	33/31/28/26	39/35/31/29	39/35/31/29
Sound Power Level	Outdoor (Cooling/Heating)	High	55/55	57/57	57/59	55/55	57/57	57/59
	Outdoor (Cooling/Heating)	High	64/63	67/69	67/69	64/63	67/69	67/69
Airflow Rate	Indoor/Outdoor (Cooling)	High	70/70	71/71	73/73	70/70	71/71	73/73
	Indoor/Outdoor (Heating)	High	2,050/3,750	2,550/4,450	2,550/4,450	2,050/3,750	2,550/4,450	2,550/4,450
Static pressure range (Standard)		Pa	1,850/3,750	2,550/4,450	2,550/4,450	1,850/3,750	2,550/4,450	2,550/4,450
Net Dimensions	Indoor	mm	300 × 1,400 × 700	300 × 1,400 × 700	300 × 1,400 × 700	300 × 1,400 × 700	300 × 1,400 × 700	300 × 1,400 × 700
	Outdoor	mm	788 × 940 × 320	998 × 940 × 320	998 × 940 × 320	788 × 940 × 320	998 × 940 × 320	998 × 940 × 320
Weight	Indoor	kg	46	46	46	46	46	46
	Outdoor	kg	52	67	67	53	67	67
Connection Pipe Diameter (Liquid/Gas)		mm	9.52/15.88	9.52/15.88	9.52/15.88	9.52/15.88	9.52/15.88	9.52/15.88
Drain Hose Diameter (I.D./O.D.)		mm	25/32	25/32	25/32	25/32	25/32	25/32
Max. Pipe Length (Pre-Charge)		m	50 (30)	50 (30)	50 (30)	50 (30)	50 (30)	50 (30)
Max. Height Difference		m	30	30	30	30	30	30
Operating Range	Cooling	°CDB	-15 to 46	-15 to 46	-15 to 46	-15 to 46	-15 to 46	-15 to 46
	Heating	°CDB	-15 to 24	-15 to 24	-15 to 24	-15 to 24	-15 to 24	-15 to 24
Refrigerant	Type (Global Warming Potential)		R32 (675)	R32 (675)	R32 (675)	R32 (675)	R32 (675)	R32 (675)
	Charge	kg (CO2eq-T)	1.90 (1.283)	2.70 (1.823)	2.70 (1.823)	1.90 (1.283)	2.70 (1.823)	2.70 (1.823)

Optional parts

* For information on the compatibility of optional parts for Intesis products, please refer to the compatibility list at the end of the "Control system & Optional parts" chapter.

Wired Remote Controller (Design type):	UTY-RVRY	Long-life filter:	UTD-LFNA	External input and output PCB:	UTY-XCSX
Compact wired remote controller:	UTY-RCRYZ1	Silver Ion Filter:	UTD-HFNA	External input and output PCB bracket:	UTZ-GXNA
Wired remote controller (touch panel):	UTY-RNRYZ6	WLAN adapter:	UTY-TFSXZ1	Network Converter for single split (DC power supply type):	UTY-VTGX
Wired remote controller:	UTY-RLRY		UTY-TFSXJ3	Network Converter for single split (AC power supply type):	UTY-VTGXV
	UTY-RNNYM	External switch controller:	UTY-TERX		
	UTY-RVNYM	IR receiver unit:	UTY-LBTYM	(Outdoor unit 36/45/54)	
Simple remote controller (without operation mode):	UTY-RHRYZ1	External Connect Kit:	UTY-XWZXZG	External connect kit:	UTY-XWZXZ3
Simple remote controller:	UTY-RSRYZ1	Remote sensor unit:	UTY-XSZXZ1		

Dimensions

(Unit: mm)

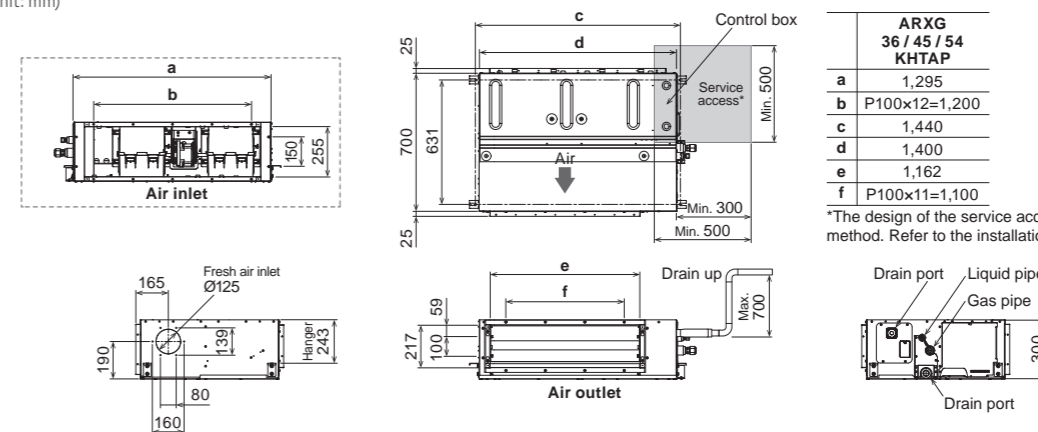

ARXG 36 / 45 / 54 KHTAP	
a	1,295
b	P100x12=1,200
c	1,440
d	1,400
e	1,162
f	P100x11=1,100

*The design of the service access depends on the installation method. Refer to the installation manual for more information.

Duct
High Static
Pressure Range
Standard
ESP up to 250 Pa



Model: ARXG45KHTB / ARXG54KHTB
ARXG45KHTB [3-phase] / ARXG54KHTB [3-phase]



Specifications

Model name	Indoor unit		ARXG45KHTB	ARXG54KHTB	ARXG45KHTB	ARXG54KHTB
	Outdoor unit		AOEG45KHTB	AOEG54KHTB	AOEG45KRTA	AOEG54KRTA
Power Source	Single phase, ~230 V, 50 Hz			3-phase, ~400 V, 50 Hz		
Capacity	Cooling	Rated	12.1	13.4	12.1	13.4
		Min.-Max.	4.0-14.0	5.0-14.5	4.0-14.0	5.0-14.5
	Heating	Rated	13.5	15.5	13.5	15.5
Min.-Max.		5.0-16.2	5.5-18.0	5.0-16.2	5.5-18.0	
Input Power	Cooling/Heating	kW	4.16/3.61	4.77/4.18	4.16/3.61	4.77/4.18
EER	Cooling	W/W	2.91	2.81	2.91	2.81
COP	Heating	W/W	3.74	3.71	3.74	3.71
Pdesign	Cooling/Heating (-10°C)	kW	12.1 / 9.2	13.4 / 9.5	12.1 / 9.2	13.4 / 9.5
SEER	Cooling	W/W	5.14	5.10	5.14	5.10
SCOP	Heating	W/W	4.00	3.96	4.00	3.96
Energy Efficiency Class	Cooling		-	-	-	-
	Heating		-	-	-	-
ηc		%	202.6	201.0	202.6	201.0
ηh		%	157.0	155.4	157.0	155.4
Max. Operating Current	Cooling/Heating	A	28.5/28.5	28.5/28.5	14.0/14.0	14.0/14.0
Annual Energy Consumption	Cooling	kWh/a	-	-	-	-
	Heating	kWh/a	-	-	-	-
Moisture Removal		l/h	1.5	2.0	1.5	2.0
Sound Pressure Level	Indoor (Cooling)	H/M/L	47/43/40	47/43/40	47/43/40	47/43/40
	Indoor (Heating)	H/M/L	47/43/40	47/43/40	47/43/40	47/43/40
	Outdoor (Cooling/Heating)	High	57/57	57/59	57/57	57/59
Sound Power Level	Indoor (Cooling/Heating)	High	75/74	75/74	75/74	75/74
	Outdoor (Cooling/Heating)	High	71/71	73/73	71/71	73/73
	Indoor/Outdoor (Cooling)	High	3,350/4,450	3,350/4,450	3,350/4,450	3,350/4,450
Airflow Rate	Indoor/Outdoor (Heating)	High	3,350/4,450	3,350/4,450	3,350/4,450	3,350/4,450
	Static pressure range (Standard)	Pa	100 to 250 (100)	100 to 250 (100)	100 to 250 (100)	100 to 250 (100)
Net Dimensions H x W x D	Indoor	mm	400 x 1,050 x 500	400 x 1,050 x 500	400 x 1,050 x 500	400 x 1,050 x 500
	Outdoor	mm	998 x 940 x 320	998 x 940 x 320	998 x 940 x 320	998 x 940 x 320
Weight	Indoor	kg	46	46	46	46
	Outdoor	kg	67	67	67	67
Connection Pipe Diameter (Liquid/Gas)		mm	9.52/15.88	9.52/15.88	9.52/15.88	9.52/15.88
Drain port Diameter (I.D./O.D.)		mm	23.4/25.4	23.4/25.4	23.4/25.4	23.4/25.4
Max. Pipe Length (Pre-Charge)		m	50 (30)	50 (30)	50 (30)	50 (30)
Max. Height Difference		m	30	30	30	30
Operating Range	Cooling	°CDB	-15 to 46	-15 to 46	-15 to 46	-15 to 46
	Heating	°CDB	-15 to 24	-15 to 24	-15 to 24	-15 to 24
Refrigerant	Type (Global Warming Potential)		R32 (675)	R32 (675)	R32 (675)	R32 (675)
	Charge	kg (CO2eq-T)	2.70 (1.823)	2.70 (1.823)	2.70 (1.823)	2.70 (1.823)

Easy Installation
(Compact & Lightweight)

The indoor and outdoor units are designed to be compact and light by reducing the basic chassis size and the overall material weight.



Design Also Suits High Static Pressure



Low Noise

Slanted corners at the top help reduce turbulent airflow. Low noise is realized by adopting a plastic case and a plastic fan.

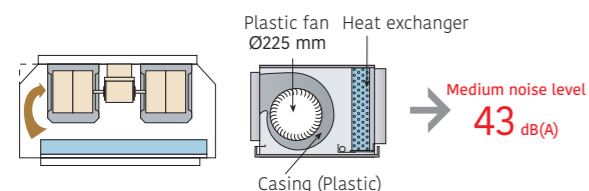

Link Up with a Variety of Central Control System (Option)

Centralized control including facilities and equipment in addition to air conditioning is possible by linking up with MODBUS, KNX interfaces.



Optional parts

* For information on the compatibility of optional parts for Intesis products, please refer to the compatibility list at the end of the "Control system & Optional parts" chapter.

Wired Remote Controller (Design type): UTY-RVRY	Remote sensor unit: UTY-XSZXZ1	Network Converter for single split (DC power supply type): UTY-VTGX
Compact wired remote controller: UTY-RCRYZ1	Long-life filter: UTD-LF60KA	Network Converter for single split (AC power supply type): UTY-VTGXV
Wired remote controller (touch panel): UTY-RNRYZ6	External switch controller: UTY-TERX	Silver Ion Filter: UTD-HFKB
Wired remote controller: UTY-RLRY	WLAN adapter: UTY-TFSXZ1	
Simple remote controller: UTY-RSRYZ1	UTY-TFSXJ3	(Outdoor unit)
	UTY-RHRYZ1	External Connect Kit: UTY-XWZXZ3
IR Receiver unit: UTY-LBTYM	External input and output PCB: UTY-XCSX+UTZ-GXEA	
	External Connect Kit: UTY-XWZXZG	

Dimensions

(Unit: mm)

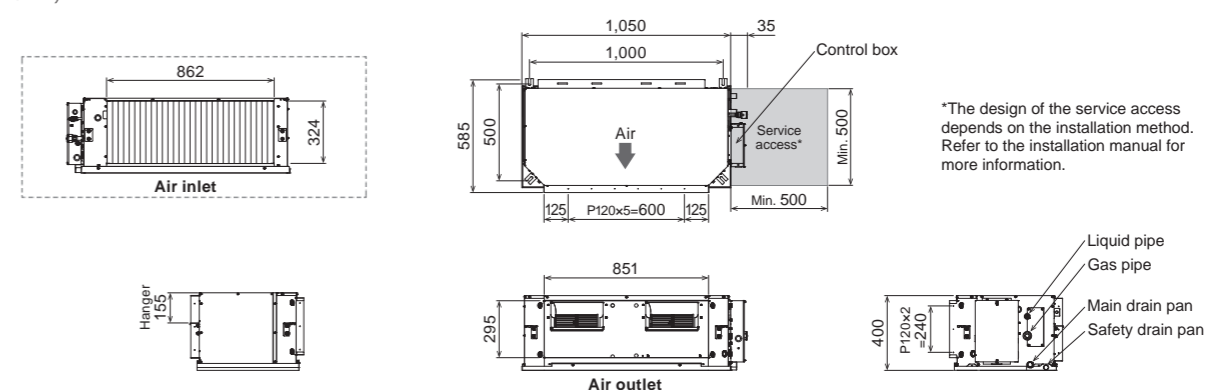

SPLIT

NEW

Duct
High Static
Pressure Range
High-Efficiency & Comfort
ESP up to 260 Pa



Model: ARXH60KHTA [3-phase]



Specifications

Model name	Indoor unit		Outdoor unit		ARXH60KHTA		AOEH60KRTA			
Power Source					3-phase, ~400 V, 50 Hz					
Capacity	Cooling	Rated	kW			15.0				
		Min.-Max.				5.0-17.5				
	Heating	Rated			18.0					
		Min.-Max.			5.1-22.4					
Input Power	Cooling/Heating		kW			4.410 / 4.740				
EER	Cooling			W/W		3.40				
COP	Heating			W/W		3.80				
Pdesign	Cooling/Heating (-10°C)		kW			15.0/10.8				
SEER	Cooling			W/W		5.00				
SCOP	Heating			W/W		3.90				
Energy Efficiency Class	Cooling						-			
	Heating						-			
η_c					%		197.0			
η_h					%		153.0			
Max. Operating Current	Cooling/Heating				A		14.5 / 14.5			
Annual Energy Consumption	Cooling				kWh/a		-			
	Heating				kWh/a		-			
Moisture Removal					l/h		2.4			
Sound Pressure Level	Indoor (Cooling)	H/M/L			dB(A)		45 / 40 / 36			
	Indoor (Heating)	H/M/L			dB(A)		45 / 40 / 36			
	Outdoor (Cooling/Heating)	High			dB(A)		53 / 55			
Sound Power Level	Indoor (Cooling/Heating)	High			dB(A)		67 / 67			
	Outdoor (Cooling/Heating)	High			dB(A)		71 / 71			
Airflow Rate	Indoor/Outdoor (Cooling)	High			m³/h		3,550 / 7,000			
	Indoor/Outdoor (Heating)	High			m³/h		3,550 / 7,000			
Static pressure range (Standard)					Pa		60 to 260 (60)			
Net Dimensions H x W x D	Indoor			mm		425 x 1,250 x 490				
	Outdoor			mm		1,418 x 970 x 370				
Weight	Indoor			kg		52				
	Outdoor			kg		95				
Connection Pipe Diameter (Liquid/Gas)					mm		9.52 / 15.88			
Drain port Diameter (I.D./O.D.)					mm		25 / 32			
Max. Pipe Length (Pre-Charge)					m		75 (30)			
Max. Height Difference					m		30			
Operating Range	Cooling				°CDB		-15 to 50			
	Heating				°CDB		-20 to 24			
Refrigerant	Type (Global Warming Potential)						R32 (675)			
	Charge				kg (CO2eq-T)		3.40 (2.295)			

High Energy Efficiency

Much greater efficiency is achieved by the use of all-DC inverter technology.

Design Also Corresponding to High Static Pressure

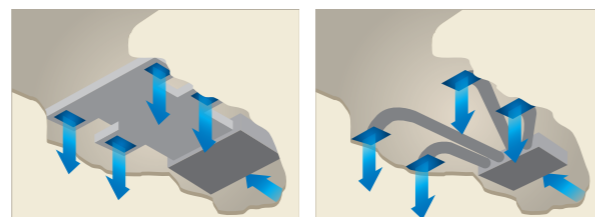
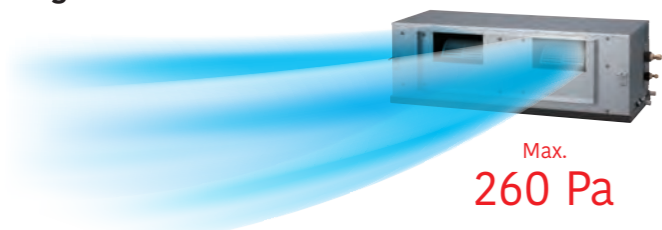

Easy Installation (Compact & Lightweight)

The indoor unit is designed to be compact and light by reducing the basic chassis size and the overall material weight.

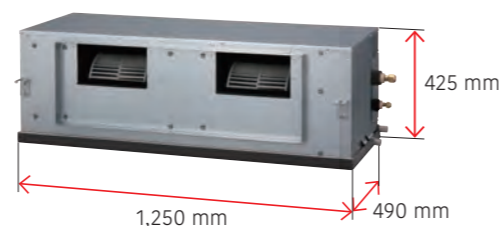

Automatic Airflow Adjustment Function

The optimum airflow can be set automatically to facilitate faster installation.

Static pressure automatically adjust !



*The remote controller is optional parts.

Link Up with a Variety of Central Control System (Option)

Centralized control including facilities and equipment in addition to air conditioning is possible by linking up with MODBUS, KNX interfaces.



Optional parts

* For information on the compatibility of optional parts for Intesis products, please refer to the compatibility list at the end of the "Control system & Optional parts" chapter.

Wired Remote Controller (Design type):	UTY-RVRY	MODBUS Converter:	UTY-VMSX	Network Converter for single split (DC power supply type):	UTY-VTGX
Compact wired remote controller:	UTY-RCRYZ1	KNX Converter:	UTY-VKXSX	Network Converter for single split (AC power supply type):	UTY-VTGXV
Wired remote controller (touch panel):	UTY-RNRYZ6	External Connect Kit:	UTY-XWZXZG	External input and output PCB:	UTY-XCSX
Wired remote controller:	UTY-RLRY	Remote sensor unit:	UTY-XSZXZ1	External input and output PCB bracket:	UTZ-GXEA
Simple remote controller (without operation mode):	UTY-RHRYZ1	IR receiver unit:	UTY-LBTYM		
Simple remote controller:	UTY-RSRYZ1	External switch controller:	UTY-TERX		
WLAN adapter:	UTY-TFSXJ3				
				(Outdoor unit)	
				External Connect Kit:	UTY-XWZXZ3

Dimensions

(Unit: mm)

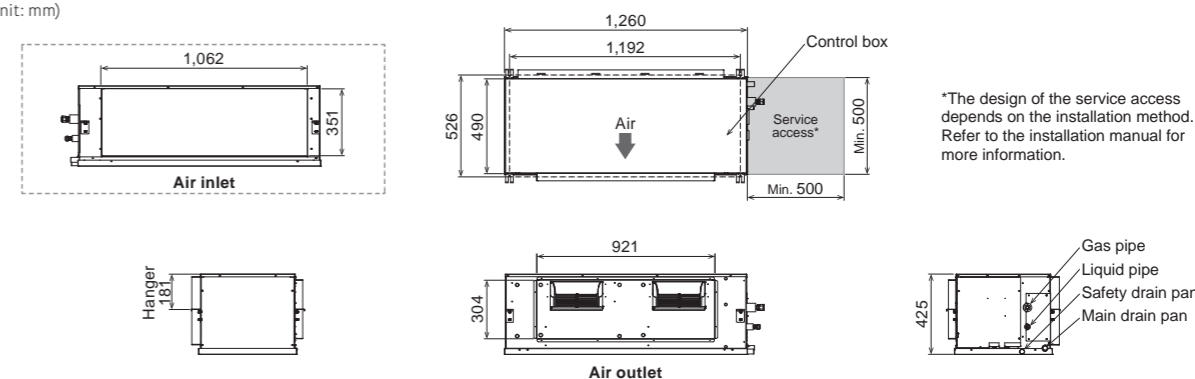

*The design of the service access depends on the installation method. Refer to the installation manual for more information.

SPLIT

Duct
High Static
Pressure Range
High-Efficiency & Comfort
ESP up to 260 Pa



High Energy Efficiency

Much greater efficiency is achieved by the use of all-DC inverter technology.

Design Also Corresponding to High Static Pressure

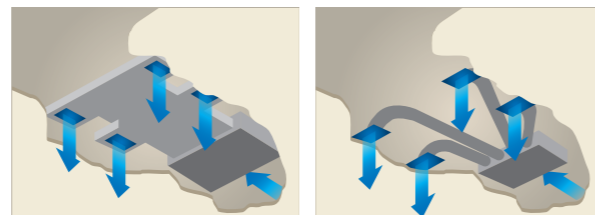
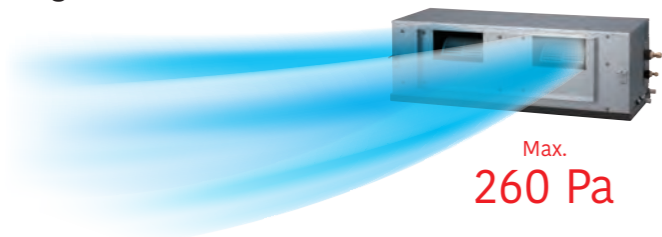

Easy Installation (Compact & Lightweight)

The indoor unit is designed to be compact and light by reducing the basic chassis size and the overall material weight.

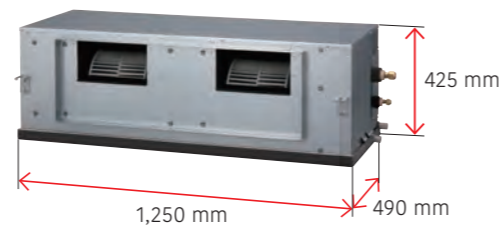

Low Noise

Slanted corners at the top help reduce turbulent airflow. Low noise is realized by adopting a plastic case and a plastic fan.

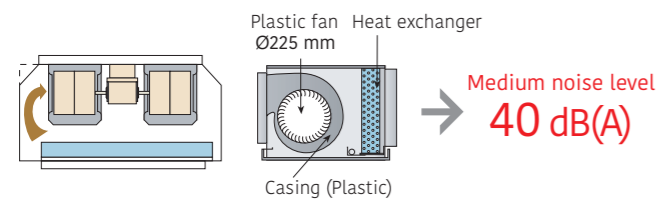

Link Up with a Variety of Central Control System (Option)

Centralized control including facilities and equipment in addition to air conditioning is possible by linking up with MODBUS, KNX interfaces.



Model: ARHG60LHTA [3-phase]



Wired RC



Specifications

Model name	Indoor unit		Outdoor unit		ARYG60LHTA	AOYG60LATT
	Indoor unit		Outdoor unit			
Power Source					3-phase, ~400 V, 50 Hz	
Capacity	Cooling	Rated	kW			15.0
		Min.-Max.				6.2-17.5
	Heating	Rated	kW			18.0
		Min.-Max.				6.2-20.0
Input Power	Cooling/Heating				4.70/5.15	
EER	Cooling				3.19	
COP	Heating				3.50	
Pdesign	Cooling/Heating				15.0 / 10.8	
SEER	Cooling				4.86	
SCOP	Heating				3.50	
ηC					191.4	
ηh					137.0	
Max. Operating Current	Cooling/Heating				12.5 / 12.5	
Moisture Removal					l/h	
Sound Pressure	Indoor (Cooling)	H/M/L/Q			45/40/36/-	
		H/M/L/Q			45/40/36/-	
	Outdoor (Cooling/Heating)	High			56/58	
Airflow Rate	Indoor/Outdoor (Cooling)	High			3,550/6,900	
		High			3,550/7,300	
Static pressure range (Standard)					Pa	
Net Dimensions	Indoor				mm	
H x W x D	Outdoor				mm	
Weight	Indoor				kg	
	Outdoor				kg	
Connection Pipe Diameter (Liquid/Gas)					mm	
Drain Hose Diameter (I.D./O.D.)					mm	
Max. Pipe Length (Pre-Charge)					m	
Max. Height Difference					m	
Operating Range	Cooling				°CDB	
	Heating				°CDB	
Refrigerant	Type (Global Warming Potential)				R410A (2,088)	
	Charge		kg (CO2eq-T)		3.45 (7.204)	

Optional parts

* For information on the compatibility of optional parts for Intesis products, please refer to the compatibility list at the end of the "Control system & Optional parts" chapter.

Wired remote controller:	UTY-RNNYM	Network Converter for single split (DC power supply type):	UTY-VTGX
Wired remote controller:	UTY-RVNYM	Network Converter for single split (AC power supply type):	UTY-VTGXV
External switch controller:	UTY-TERX	External Connect Kit:	UTD-ECS5A
WLAN adapter:	UTY-TFNXZ1		
Remote sensor unit:	UTY-XSZXZ1	(Outdoor unit)	
IR receiver unit	UTY-LRHYM	External Connect Kit:	UTY-XWZXZ2

Dimensions

(Unit: mm)

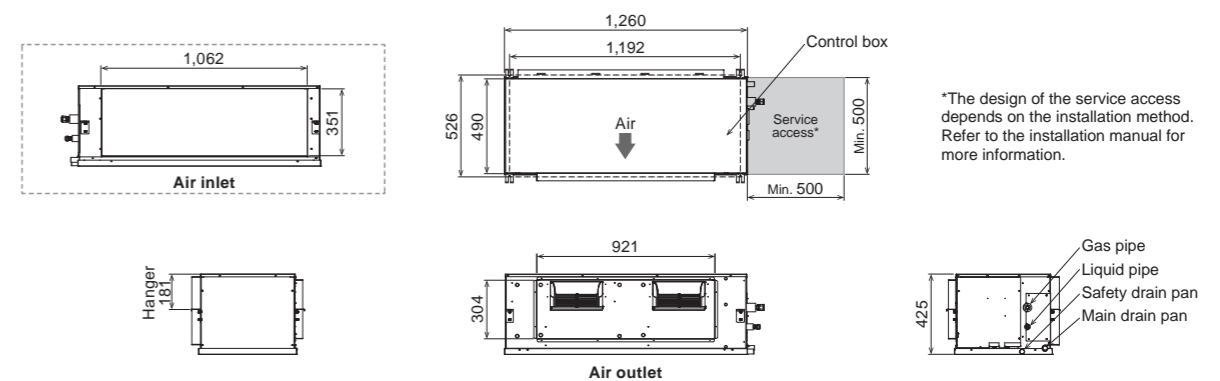

*The design of the service access depends on the installation method. Refer to the installation manual for more information.

Duct
High Static Pressure Range
High-Efficiency ESP up to 200 Pa



Model: ARXH72KHTA / ARXH90KHTA [3-phase]



Specifications

Model name	Indoor unit		Outdoor unit		ARXH72KHTA	ARXH90KHTA
	AOEH72KRTA		AOEH90KRTA			
Power Source	3-phase, ~400 V, 50 Hz					
Capacity	Cooling	Rated	kW	19.0		22.0
		Min.-Max.		6.0-22.0		6.5-24.2
	Heating	Rated	kW	22.4		25.0
		Min.-Max.		6.0-25.0		6.5-26.0
Input Power	Cooling/Heating		kW	6.030 / 6.200		7.330 / 7.360
EER	Cooling		W/W	3.15		3.00
COP	Heating		W/W	3.61		3.40
Pdesign	Cooling/Heating (-10°C)		kW	19.0/17.0		22.0/18.5
SEER	Cooling		W/W	5.70		5.40
SCOP	Heating		W/W	3.94		3.70
Energy Efficiency Class	Cooling			-		-
	Heating			-		-
ηc			%	225.0		213.0
ηh			%	154.6		145.0
Max. Operating Current	Cooling/Heating		A	18.0 / 18.0		18.0 / 18.0
Annual Energy Consumption	Cooling		kWh/a	-		-
	Heating		kWh/a	-		-
Moisture Removal			l/h	4.6		6.1
Sound Pressure Level	Indoor (Cooling)	H/M/L/Q	dB(A)	43 / 41 / 38 / 35		44 / 42 / 40 / 37
	Indoor (Heating)	H/M/L/Q		43 / 41 / 38 / 35		44 / 42 / 40 / 37
Sound Power Level	Outdoor (Cooling/Heating)	High	dB(A)	61 / 64		61 / 64
	Indoor (Cooling/Heating)	High		73 / 73		74 / 74
	Outdoor (Cooling/Heating)	High		75 / 75		77 / 77
	Indoor/Outdoor (Heating)	High		3,800 / 9,600		4,100 / 9,600
Airflow Rate	Indoor/Outdoor (Cooling)	High	m³/h	3,800 / 9,600		4,100 / 9,600
Static pressure range (Standard)			Pa	60 to 200 (72)		60 to 200 (72)
Net Dimensions	Indoor	mm	360 × 1,400 × 850		360 × 1,400 × 850	
H x W x D	Outdoor	mm	1,418 × 970 × 370		1,418 × 970 × 370	
Weight	Indoor	kg	69		69	
	Outdoor	kg	103		103	
Connection Pipe Diameter (Liquid/Gas)			mm	12.7 / 19.05		12.7 / 19.05
Drain port Diameter (I.D./O.D.)			mm	31 / 32		31 / 32
Max. Pipe Length (Pre-Charge)			m	100 (40)		100 (40)
Max. Height Difference			m	30		30
Operating Range	Cooling		°CDB	-15 to 50		-15 to 50
	Heating		°CDB	-20 to 24		-20 to 24
Refrigerant	Type (Global Warming Potential)			R32 (675)		R32 (675)
	Charge		kg (CO2eq-T)	4.00 (2,700)		4.00 (2,700)

Lightweight and Compact Design

The indoor unit can be split into fan unit and heat exchanger unit. Split units can pass through a ventilation opening, helping to reduce installation time.

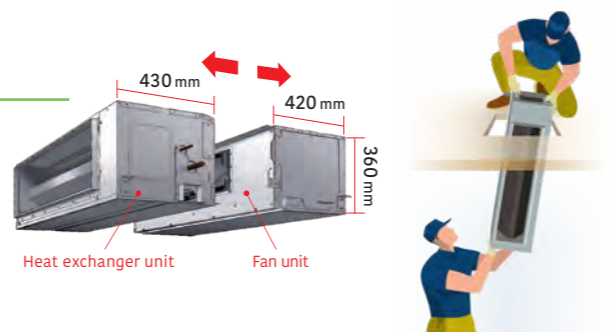

Easy To Transport

A handle has been added to the indoor unit to make it easier to carry.



Quiet Operation

The combination of a V-shaped heat exchanger, an air stabilizer, and a high-efficiency DC fan motor enables this compact unit to operate quietly.

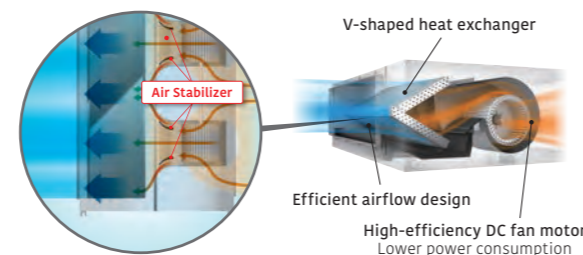

Automatic Airflow Adjustment Function

The optimum airflow can be set automatically to facilitate faster installation.

Static pressure automatically adjust !



*The remote controller is optional parts.

Link Up with a Variety of Central Control System (Option)

Centralized control including facilities and equipment in addition to air conditioning is possible by linking up with MODBUS, KNX interfaces.



Optional parts

* For information on the compatibility of optional parts for Intesis products, please refer to the compatibility list at the end of the "Control system & Optional parts" chapter.

Wired Remote Controller (Design type): UTY-RVRY	WLAN adapter: UTY-TFSXJ3	Network Converter for single split (DC power supply type): UTY-VTGX
Compact wired remote controller: UTY-RCRYZ1	Long-life filter: UTD-LFKA	Network Converter for single split (AC power supply type): UTY-VTGXV
Wired remote controller (touch panel): UTY-RNRYZ6	MODBUS Converter: UTY-VMSX	External input and output PCB: UTY-XCSX
Wired remote controller: UTY-RLRY	KNX Converter: UTY-VKXS	External input and output PCB bracket: UTZ-GXNA
Simple remote controller (without operation mode): UTY-RHRYZ1	Drain pump unit: UTZ-PX1NAB	
Simple remote controller: UTY-RSRYZ1	Silver Ion Filter: UTD-HFKA	(Outdoor unit)
External switch controller: UTY-TERX	External Connect Kit: UTY-XWZXZG	External Connect Kit: UTY-XWZXZ3
IR receiver unit: UTY-LBTYM	Remote sensor unit: UTY-XSZXZ1	L-type piping kit: UTP-FX06A

Dimensions

(Unit: mm)

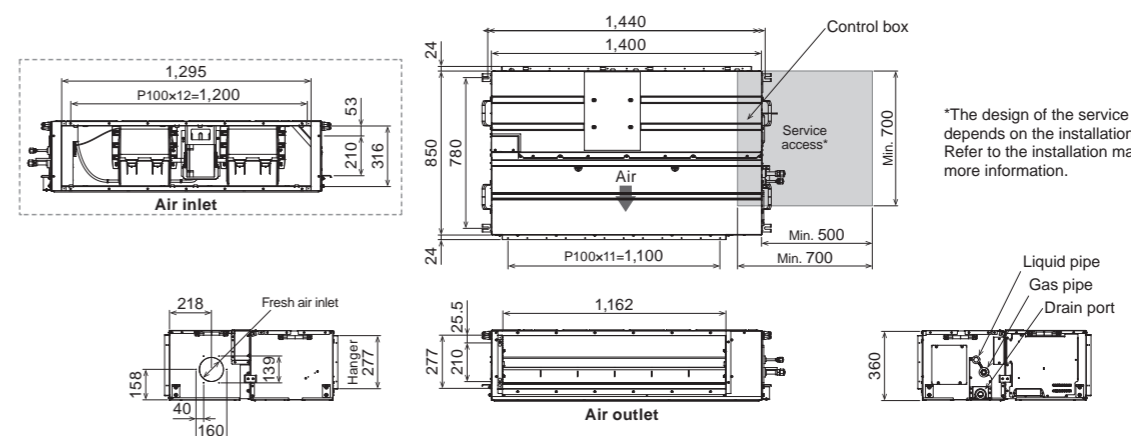

*The design of the service access depends on the installation method. Refer to the installation manual for more information.

SPLIT

Duct
High Static Pressure Range
Standard
ESP up to 200 Pa*
(*72:150 Pa)



Lightweight and Compact Design

The indoor unit can be split into fan unit and heat exchanger unit. Split units can pass through a ventilation opening, helping to reduce installation time.

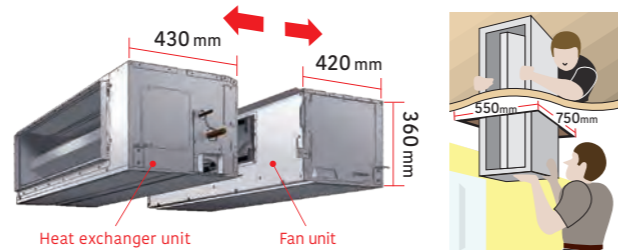

Quiet Operation

The combination of a V-shaped heat exchanger, an air stabilizer, and a high-efficiency DC fan motor enables this compact unit to operate quietly.

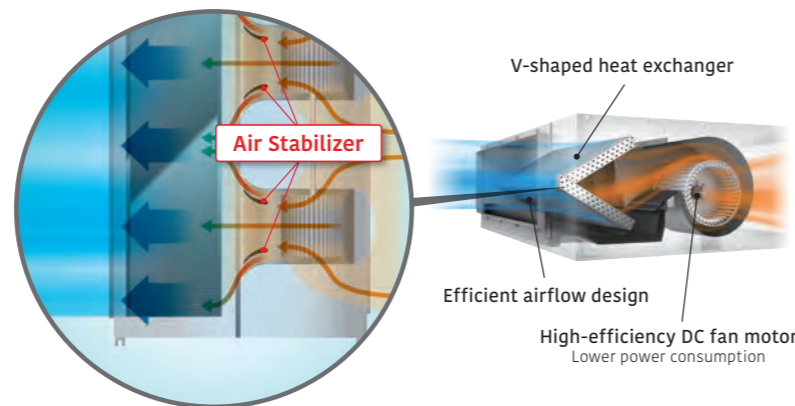

Automatic Airflow Adjustment Function

The optimum airflow can be set automatically to facilitate faster installation.

Static pressure automatically adjust !



Link Up with a Variety of Central Control System (Option)

Centralized control including facilities and equipment in addition to air conditioning is possible by linking up with MODBUS, KNX interfaces.



Model: ARYG72LHTA / ARYG90LHTA



Wired RC



Specifications

Model name	Indoor unit		ARYG72LHTA		ARYG90LHTA	
	Outdoor unit		AOYG72LRLA		AOYG90LRLA	
Power Source	Indoor		Single phase, ~230 V, 50 Hz			
	Outdoor		3-phase, ~400 V, 50 Hz			
Capacity	Cooling	Rated	19.0		22.0	
		Min.-Max.	8.4-20.9		10.3-24.2	
	Heating	Rated	22.4		27.0	
		Min.-Max.	7.2-24.6		8.5-29.7	
Input Power	Cooling/Heating	kW	6.46/6.59		7.77/8.18	
EER	Cooling	W/W	2.94		2.83	
COP	Heating	W/W	3.40		3.30	
Pdesign	Cooling/Heating	kW	19.0 / 15.3		22.0 / 18.5	
SEER	Cooling	W/W	5.22		5.14	
SCOP	Heating	W/W	3.94		3.92	
ηc		%	205.8		202.6	
Max. Operating Current	Indoor (Cooling/Heating)		4.6 / 4.6		6.0 / 6.0	
	Outdoor (Cooling/Heating)		15.8 / 15.8		20.6 / 20.6	
Moisture Removal		l/h	4.5		6.0	
Sound Pressure	Indoor (Cooling)	H/M/L/Q	46/43/41/39		47/44/42/40	
	Indoor (Heating)	H/M/L/Q	46/43/41/39		47/44/42/40	
	Outdoor (Cooling/Heating)	High	55/55		55/57	
Airflow Rate	Indoor/Outdoor (Cooling)	High	4,300/8,400		4,300/8,400	
	Indoor/Outdoor (Heating)	High	4,300/8,400		4,300/9,000	
Static pressure range (Standard)		Pa	50 to 150 (72)		50 to 200 (72)	
Net Dimensions H x W x D	Indoor		360 x 1,400 x 850		360 x 1,400 x 850	
	Outdoor		1,428 x 1,080 x 480		1,428 x 1,080 x 480	
Weight	Indoor		69		80	
	Outdoor		165		174	
Connection Pipe Diameter (Liquid/Gas)		mm	12.7/25.4		12.7/25.4	
Drain Hose Diameter (I.D./O.D.)		mm	25/32		25/32	
Max. Pipe Length (Pre-Charge)		m	100 (30)		100 (30)	
Max. Height Difference		m	30		30	
Operating Range	Cooling		-15 to 46		-15 to 46	
	Heating		-20 to 24		-20 to 24	
Refrigerant	Type (Global Warming Potential)		R410A (2,088)		R410A (2,088)	
	Charge		kg (CO2eq-T)		5.6 (11.693) / 7.1 (14.825)	

Optional parts

* For information on the compatibility of optional parts for Intesis products, please refer to the compatibility list at the end of the "Control system & Optional parts" chapter.

Wired Remote Controller (Design type):	UTY-RVRY	WLAN adapter:	UTY-TFSXZ1	Network Converter for single split (DC power supply type):	UTY-VTGX
Compact wired remote controller:	UTY-RCRYZ1		UTY-TFSXJ3	Network Converter for single split (AC power supply type):	UTY-VTGXV
Wired remote controller (touch panel):	UTY-RNRYZ6	External input and output PCB:	UTY-XCSX	IR receiver unit:	UTY-LBTYM
Wired remote controller:	UTY-RLRY	Remote sensor unit:	UTY-XSZXZ1	Silver Ion Filter:	UTD-HFKA
	UTY-RNNYM	Long-life filter:	UTD-LFKA		
	UTY-RVNYM	External Connect Kit:	UTY-XWZXZG	(Outdoor unit)	
Simple remote controller (without operation mode):	UTY-RHRYZ1	Drain pump unit:	UTZ-PX1NAB	External Connect Kit:	UTY-XWZXZ3
Simple remote controller:	UTY-RSRYZ1	External switch controller:	UTY-TERX		

Dimensions

(Unit: mm)

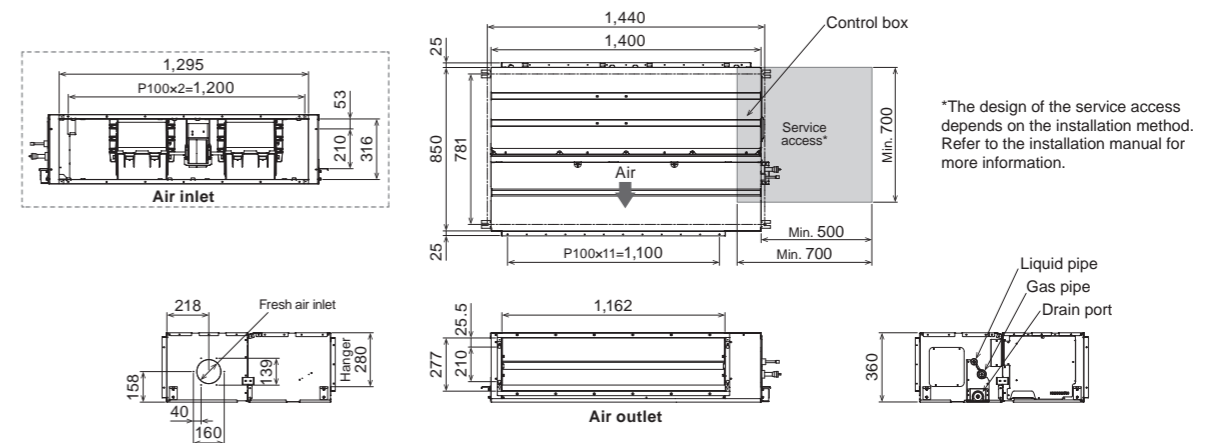

*The design of the service access depends on the installation method. Refer to the installation manual for more information.

SPLIT

Floor Compact Size



High Energy Saving

The Floor 09 class achieves a top-class SEER of 8.50 and an A+++ seasonal efficiency class for cooling. The Floor 09 class achieves an improved SCOP of 4.30 and an A+ seasonal efficiency class for heating.

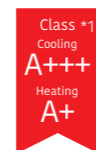

SEER 8.50^{*1} SCOP 4.30^{*1}

*1: 09 model

Flexible & Easy Installation

The compact and whole-surface suction design provides flexible installation options, including floor-standing, embedded, half concealed, and wall mount installation to match the room layout.

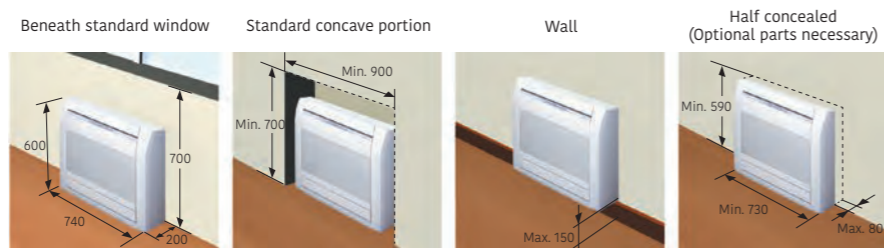

* Concave position installation with concealment is prohibited.

Low Ambient Operation

Factory-guaranteed cooling operation down to -10°C ambient temperature.

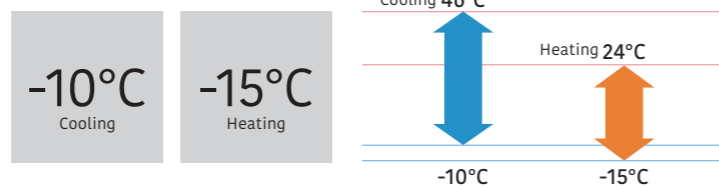

Smart Device Control (Option)

With the optional WLAN adapter installed in the air conditioner, you can control it from anywhere with your smart device.

* See page C-022 for details on smart device control.



10°C Heat

The room temperature can be set to go no lower than 10°C, thus ensuring that the room does not get too cold when not occupied.

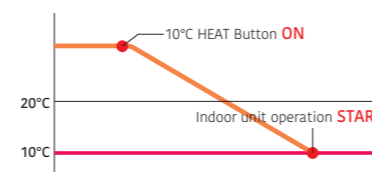

Model: AGE09KVCA / AGE12KVCA / AGE14KVCA



Specifications

Model name	Indoor unit		AGE09KVCA		AGE12KVCA		AGE14KVCA	
	Outdoor unit		AOEG09KVCA		AOEG12KVCA		AOEG14KVCA	
Power Source			Single phase, ~230 V, 50 Hz					
Capacity	Cooling	Rated	2.5		3.5		4.2	
		Min.-Max.	0.9-3.5		0.9-4.0		0.9-5.2	
	Heating	Rated	3.5		4.5		5.2	
Min.-Max.		0.9-5.1		0.9-5.3		0.9-6.3		
Input Power	Cooling/Heating	kW	0.53/0.81		0.88/1.22		1.06/1.41	
EER	Cooling	W/W	4.70		4.00		3.95	
COP	Heating	W/W	4.30		3.70		3.70	
Pdesign	Cooling/Heating (-10°C)	kW	2.50/2.60		3.50/3.50		4.20/4.20	
SEER	Cooling	W/W	8.50		8.20		8.10	
SCOP	Heating (Average)	W/W	4.30		4.10		4.00	
Energy Efficiency Class	Cooling		A+++		A++		A+	
	Heating (Average)		A+		A+		A+	
Max. Operating Current	Cooling/Heating	A	7.0/8.5		7.0/8.5		11.0/12.0	
Annual Energy Consumption	Cooling	kWh/a	103		149		181	
	Heating (Average)	kWh/a	845		1,192		1,466	
Moisture Removal		l/h	1.3		1.8		2.1	
Sound Pressure Level	Indoor (Cooling)	H/M/L/Q	40/35/29/22		40/35/29/22		44/38/31/22	
	Indoor (Heating)	H/M/L/Q	41/35/29/22		41/35/29/22		43/37/29/22	
Sound Power Level	Outdoor (Cooling/Heating)	High	43/47		45/51		51/50	
	Indoor (Cooling/Heating)	High	53/54		53/54		57/56	
	Outdoor (Cooling/Heating)	High	58/61		61/64		63/63	
Airflow Rate	Indoor/Outdoor (Cooling)	High	570/1,530		570/1,530		650/2,210	
	Indoor/Outdoor (Heating)	High	600/1,510		600/1,510		650/2,100	
Net Dimensions H x W x D	Indoor	mm	600 x 740 x 200		600 x 740 x 200		600 x 740 x 200	
	Outdoor	mm	542 x 799 x 290		542 x 799 x 290		632 x 799 x 290	
Weight	Indoor	kg	14		14		14	
	Outdoor	kg	31		31		38	
Connection Pipe Diameter (Liquid/Gas)		mm	6.35/9.52		6.35/9.52		6.35/9.52	
Drain Hose Diameter (I.D./O.D.)			13.8/15.8 to 16.7		13.8/15.8 to 16.7		13.8/15.8 to 16.7	
Max. Pipe Length (Pre-Charge)		m	20 (15)		20 (15)		20 (15)	
Max. Height Difference			15		15		15	
Operating Range	Cooling	°CDB	-10 to 46		-10 to 46		-10 to 46	
	Heating	°CDB	-15 to 24		-15 to 24		-15 to 24	
Refrigerant	Type (Global Warming Potential)		R32 (675)		R32 (675)		R32 (675)	
	Charge	kg (CO2eq-T)	0.85 (0.574)		0.85 (0.574)		0.94 (0.635)	

Optional parts

* For information on the compatibility of optional parts for Intesis products, please refer to the compatibility list at the end of the "Control system & Optional parts" chapter.

Wired Remote Controller (Design type): UTY-RVRY	Simple remote controller: UTY-RSRYZ1	Network Converter for single split (DC power supply type): UTY-VTGX
Compact wired remote controller: UTY-RCRYZ1	External switch controller: UTY-TERX	Network Converter for single split (AC power supply type): UTY-VTGXV
Wired remote controller (touch panel): UTY-RNRYZ6	WLAN adapter: UTY-TFSXZ1	Silver Ion Filter: UTR-FA03-5
Wired remote controller: UTY-RLRY	UTY-TFSXJ3	External Connect Kit: UTY-XWZXZ5
Simple remote controller (without operation mode): UTY-RHRYZ1	Half Connect Kit: UTR-STA	Communication Kit: UTY-TWRXZ3

Dimensions

(Unit: mm)

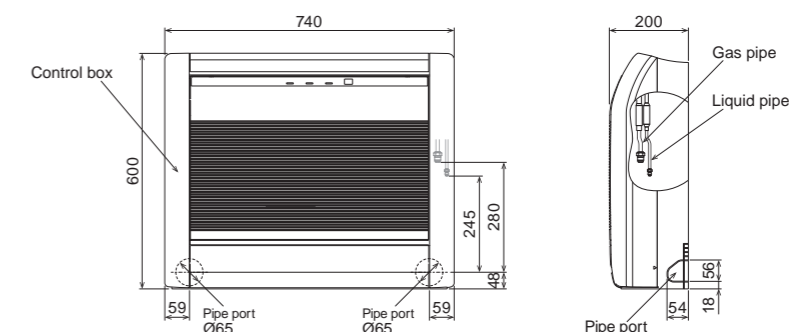

Ceiling

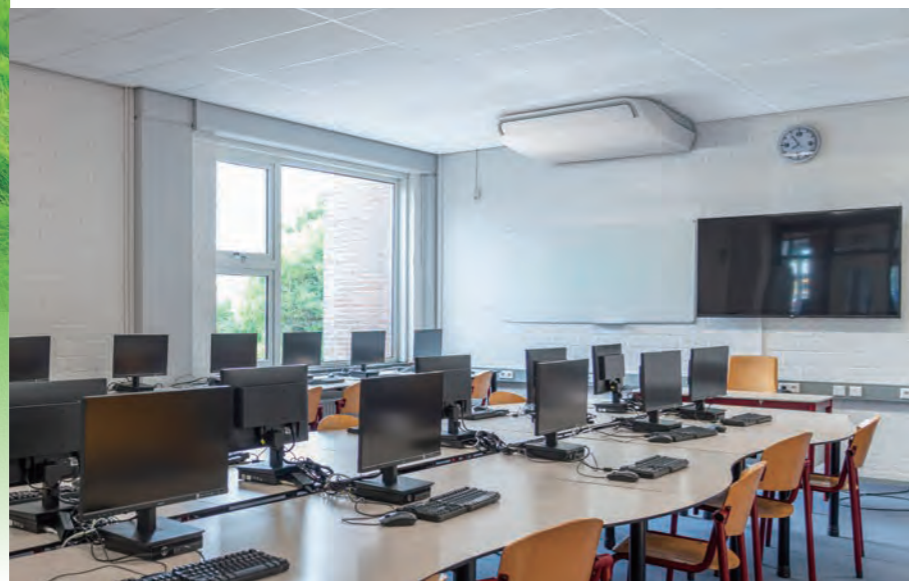

(30/36/45/54)

Light Elegant Design

The light-elegant, gently curved surface gives a sense of comfort and well-being.



Easy Installation

The indoor unit can be easily installed under the ceiling thanks to the uniquely designed mounting kit.

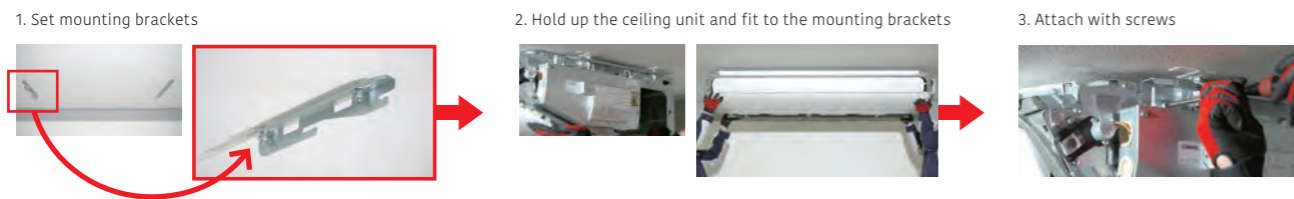

Easy Maintenance

The front panel can be opened without removing it for safe & speedy maintenance.



The drain pan can be removed for cleaning.



Components in the control box can be easily accessed from the wide side opening.



Flexible Installation

The drain hose and pipe can be contained in the casing and connected in the right, left, angled, or downward direction.



Link Up with a Variety of Central Control System (Option)

Centralized control including facilities and equipment in addition to air conditioning is possible by linking up with MODBUS, KNX interfaces.



Model: ABEG18KRTA / ABEG22KRTA / ABEG24KRTA / ABEG30KRTA / ABEG36KRTA / ABEG45KRTA
ABEG36KRTA [3-phase] / ABEG45KRTA [3-phase] / ABEG54KRTA [3-phase]



Specifications

Model name	Indoor unit						Outdoor unit				
	ABEG18KRTA	ABEG22KRTA	ABEG24KRTA	ABEG30KRTA	ABEG36KRTA	ABEG45KRTA	ABEG36KRTA	ABEG45KRTA	ABEG54KRTA		
Power Source	Single phase, ~230 V, 50 Hz						3-phase, ~400 V, 50 Hz				
Capacity	Cooling	Rated	6.0	6.8	8.5	9.5	12.1	9.5	12.1	13.4	
		Min.-Max.	0.9-5.9	0.9-6.7	0.9-8.0	2.8-10.0	2.8-11.2	4.0-13.5	2.8-11.2	4.0-13.5	4.5-14.5
	Heating	Rated	6.0	7.0	7.5	10.0	10.8	13.5	10.8	13.5	15.5
Input Power	Cooling/Heating	Min.-Max.	0.9-7.5	0.9-8.0	0.9-9.1	2.7-11.2	2.7-12.7	4.2-16.2	2.7-12.7	4.2-16.2	4.7-16.5
		Rated	1.55/1.62	1.87/1.95	2.14/1.97	2.65/2.77	2.96/2.88	4.22/3.84	2.96/2.88	4.22/3.84	4.45/4.43
EER	Cooling	3.35	3.21	3.18	3.21	3.21	2.87	3.21	2.87	3.01	
COP	Heating	3.70	3.59	3.81	3.61	3.75	3.52	3.75	3.52	3.50	
Pdesign	Cooling/Heating (-10°C)	5.2/4.4	6.0/4.8	6.8/6.0	8.5/8.0	9.5/8.7	12.1/9.2	9.5/8.7	12.1/9.2	13.4/9.5	
SEER	Cooling	6.2	6.1	6.2	6.1	6.37	6.24	6.37	6.24	5.88	
SCOP	Heating (Average)	4.1	4.0	4.1	4.0	4.21	4.05	4.21	4.05	3.95	
Energy Efficiency Class	Cooling	A++	A++	A++	A++	A++	-	A++	-	-	
	Heating (Average)	A+	A+	A+	A+	A+	-	A+	-	-	
ηc		-	-	-	-	-	246.8	-	246.8	232.2	
ηh		-	-	-	-	-	158.9	-	158.9	155.0	
Max. Operating Current	Cooling/Heating	12.1/12.1	12.6/12.6	13.6/13.6	22.6/22.6	22.6/22.6	28.5/28.5	10.5/10.5	14.0/14.0	14.0/14.0	
	Cooling	293	344	384	486	524	-	524	-	-	
Annual Energy Consumption	Cooling	1,501	1,677	2,042	2,796	2,904	-	2,904	-	-	
	Heating	2.0	2.5	2.2	3.0	2.6	4.5	2.6	4.5	5.0	
Moisture Removal	Indoor (Cooling)	38/36/33/31	42/37/34/31	41/36/32/29	45/40/35/32	44/40/37/32	45/41/39/34	44/40/37/32	45/41/39/34	48/44/41/38	
	Outdoor (Cooling/Heating)	50/50	51/51	53/54	53/55	55/55	57/57	55/55	57/57	57/59	
Sound Pressure Level	Indoor (Cooling/Heating)	53/53	57/57	56/56	60/60	59/59	60/60	59/59	60/60	63/63	
	Outdoor (Cooling/Heating)	62/62	63/63	65/66	68/69	70/70	71/71	70/70	71/71	73/73	
Airflow Rate	Indoor/Outdoor (Cooling)	840/2,160	900/2,240	1,230/2,700	1,400/3,750	1,850/3,750	1,900/4,450	1,850/3,750	1,900/4,450	2,100/4,450	
	Indoor/Outdoor (Heating)	840/1,830	900/1,960	1,230/2,700	1,400/3,750	1,800/3,750	1,850/4,450	1,800/3,750	1,850/4,450	2,100/4,450	
Net Dimensions H x W x D	Indoor	235 × 1,080 × 705	235 × 1,080 × 705	235 × 1,390 × 705	235 × 1,390 × 705	235 × 1,700 × 705	235 × 1,700 × 705	235 × 1,700 × 705	235 × 1,700 × 705	235 × 1,700 × 705	
	Outdoor	632 × 799 × 290	632 × 799 × 290	716 × 820 × 315	788 × 940 × 320	788 × 940 × 320	998 × 940 × 320	788 × 940 × 320	998 × 940 × 320	998 × 940 × 320	
Weight	Indoor	24	24	31	31	38	38	38	38	38	
	Outdoor	36	38	42	52	52	67	53	67	67	
Connection Pipe Diameter (Liquid/Gas)		6.35/12.7	6.35/12.7	6.35/12.7	9.52/15.88	9.52/15.88	9.52/15.88	9.52/15.88	9.52/15.88	9.52/15.88	
Drain Hose Diameter (I.D./O.D.)		25/32	25/32	25/32	25/32	25/32	25/32	25/32	25/32	25/32	
Max. Pipe Length (Pre-Charge)		30 (20)	30 (20)	30 (20)	50 (30)	50 (30)	50 (30)	50 (30)	50 (30)	50 (30)	
Max. Height Difference		20	25	25	30	30	30	30	30	30	
Operating Range	Cooling	-15 to 46	-15 to 46	-15 to 46	-15 to 46	-15 to 46	-15 to 46	-15 to 46	-15 to 46	-15 to 46	
	Heating	-15 to 24	-15 to 24	-15 to 24	-15 to 24	-15 to 24	-15 to 24	-15 to 24	-15 to 24	-15 to 24	
Refrigerant	Type (Global Warming Potential)	R32 (675)	R32 (675)	R32 (675)	R32 (675)	R32 (675)	R32 (675)	R32 (675)	R32 (675)	R32 (675)	
	Charge	1.02 (0.689)	1.25 (0.844)	1.25 (0.844)	1.90 (1.283)	1.90 (1.283)	2.70 (1.823)	1.90 (1.283)	2.70 (1.823)	2.70 (1.823)	

* For information on the compatibility of optional parts for Intesis products, please refer to the compatibility list at the end of the "Control system & Optional parts" chapter.

Wired Remote Controller (Design type): UTY-RVRY	UTY-RCRY1	WLAN adapter: UTY-TFSXZ1	UTY-TFSXJ3	Network Converter for single split (DC power supply type): UTY-VTGX
Compact wired remote controller: UTY-RNRYZ6	UTY-RLRY	Drain pump unit: UTR-DPB24T	IR receiver unit: UTY-LBTYH	Network Converter for single split (AC power supply type): UTY-VTGVX
Wired remote controller (touch panel): UTY-RRLRY	UTY-RHRYZ1	L-type Piping Kit: UTP-FX24A (18/22/24)	UTP-FX35A (30/36/45/54)	External switch controller: UTY-TERX
Simple remote controller (without operation mode): UTY-RSRYZ1	UTY-XCSX	Communication Kit: UTY-TWRXZ3	External Connect Kit: UTY-XWZXZG	(Outdoor unit 30/36/45/54)
Simple remote controller: UTY-RSRYZ1	UTZ-GXEA			External Connect Kit: UTY-XWZXZ3
External input and output PCB: UTY-XCSX				
External input and output PCB box: UTY-XCSX				

Dimensions

(Unit: mm)

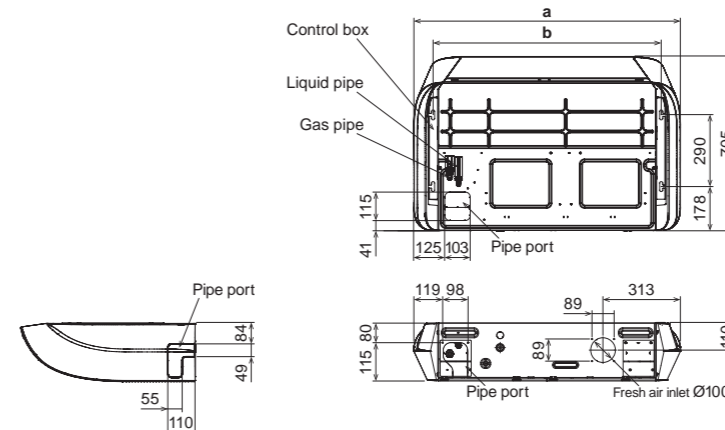

	ABEG 18/22KRTA	ABEG 24/30KRTA	ABEG 36/45/54 KRTA
a	1,080	1,390	1,700
b	923	1,233	1,543



Wall-Mounted Specifications



Designer series High Spec & Design (WLAN adapter Option Models)

Model name	Indoor unit		ASYPH07KJCA ASYPH07KJCA-B	ASYPH09KJCA ASYPH09KJCA-B	ASYPH12KJCA ASYPH12KJCA-B	ASYPH14KJCA ASYPH14KJCA-B
	Outdoor unit		AOYPH07KJCA	AOYPH09KJCA	AOYPH12KJCA	AOYPH14KJCA
Power Source			Single phase, 230V, ~50Hz			
Capacity	Cooling	Rated	2.0	2.5	3.4	4.2
		Min-Max	0.9-3.0	0.9-3.2	0.9-3.9	0.9-4.3
	Heating	Rated	2.5	2.8	4.0	5.2
		Min-Max	0.9-3.6	0.9-4.5	0.9-5.4	0.9-5.9
Input Power	Cooling/Heating	kW	0.400 / 0.500	0.550 / 0.600	0.870 / 0.950	1.260 / 1.400
EER	Cooling	W/W	5.00	4.55	3.91	3.33
COP	Heating	W/W	5.00	4.67	4.21	3.71
Pdesign	Cooling/Heating(-10°C)	kW	2.0 / 2.3	2.5 / 2.4	3.4 / 2.5	4.2 / 4.0
SEER	Cooling	W/W	9.60	9.20	8.70	7.90
SCOP	Heating (Average)	W/W	5.10	5.10	5.10	4.60
Energy Efficiency Class	Cooling		A+++	A+++	A+++	A++
	Heating (Average)		A+++	A+++	A+++	A++
Max. Operating Current	Cooling/Heating	A	6.5 / 9.0	6.5 / 9.0	6.5 / 9.0	7.0 / 9.0
Annual Energy Consumption	Cooling	kWh/a	73	95	137	186
	Heating	kWh/a	631	658	685	1,216
Moisture Removal		l/h	1.0	1.0	1.5	1.6
Sound Pressure Level	Indoor (Cooling)	H/M/L/Q	36 / 31 / 24 / 19	38 / 31 / 24 / 19	41 / 34 / 25 / 20	45 / 35 / 25 / 20
	Indoor (Heating)	H/M/L/Q	38 / 31 / 24 / 20	38 / 31 / 24 / 20	41 / 34 / 25 / 21	44 / 35 / 25 / 21
	Outdoor (Cooling/Heating)	High	42 / 42	44 / 44	47 / 47	47 / 52
	Outdoor (Cooling/Heating)	High	51 / 52	52 / 52	56 / 56	59 / 59
Sound Power Level	Indoor (Cooling/Heating)	High	55 / 54	56 / 55	58 / 59	59 / 63
	Outdoor (Cooling/Heating)	High	540 / 1,390	580 / 1,480	630 / 1,690	720 / 1,690
Airflow Rate	Indoor / Outdoor (Cooling)	High	580 / 1,350	580 / 1,420	630 / 1,690	720 / 1,860
Net Dimensions H x W x D	Indoor	mm	270 x 798 x 240	270 x 798 x 240	270 x 798 x 240	270 x 798 x 240
	Outdoor	mm	542 x 799 x 290	542 x 799 x 290	542 x 799 x 290	542 x 799 x 290
Weight	Indoor	kg	10	10	10.5	10.5
	Outdoor	kg	30	30	31	31
Connection Pipe Diameter (Liquid / Gas)		mm	6.35 / 9.52	6.35 / 9.52	6.35 / 9.52	6.35 / 9.52
Drain hose Diameter (I.D./O.D.)		mm	13.8 / 15 to 16.8	13.8 / 15 to 16.8	13.8 / 15 to 16.8	13.8 / 15 to 16.8
Max. Pipe Length (Pre-Charge)		m	20 (15)	20 (15)	20 (15)	20 (15)
Max. Height Difference			15	15	15	15
Operating Range	Cooling	°CDB	-10 to 50	-10 to 50	-10 to 50	-10 to 50
	Heating	°CDB	-20 to 24	-20 to 24	-20 to 24	-20 to 24
Refrigerant	Type (Global Warming Potential)		R32 (675)	R32 (675)	R32 (675)	R32 (675)
	Charge	kg (CO2eq-T)	0.72 (0.486)	0.72 (0.486)	0.87 (0.587)	0.87 (0.587)

Standard series High-Efficiency & Comfort



Model name	Indoor unit	WLAN Adapter Internal Models	ASYPG07KMCF	ASYPG09KMCF	ASYPG12KMCF	ASYPG14KMCF
		WLAN Adapter Option Models	ASYPG07KMCE	ASYPG09KMCE	ASYPG12KMCE	ASYPG14KMCE
Outdoor unit		AOYPG07KMCC	AOYPG09KMCC	AOYPG12KMCC	AOYPG14KMCC	
Power Source			Single phase, ~230 V, 50 Hz			
Capacity	Cooling	Rated	2.0	2.5	3.4	4.2
		Min.-Max.	0.9-3.0	0.9-3.2	0.9-3.9	0.9-4.4
	Heating	Rated	2.5	2.8	4.0	5.4
		Min.-Max.	0.9-3.4	0.9-4.0	0.9-5.3	0.9-6.0
Input Power	Cooling/Heating	kW	0.450/0.555	0.630/0.620	0.935/0.960	1.220/1.410
EER	Cooling	W/W	4.43	3.97	3.65	3.44
COP	Heating	W/W	4.52	4.52	4.17	3.83
Pdesign	Cooling/Heating (-10°C)	kW	2.0/2.3	2.5/2.4	3.4/2.5	4.2/4.0
SEER	Cooling	W/W	7.40	7.40	7.30	6.90
SCOP	Heating (Average)	W/W	4.10	4.10	4.40	4.10
Energy Efficiency Class	Cooling		A++	A++	A++	A++
	Heating (Average)		A+	A+	A+	A+
Max. Operating Current	Cooling/Heating	A	6.5/9.0	6.5/9.0	6.5/9.0	6.5/9.0
Annual Energy Consumption	Cooling	kWh/a	95	118	163	213
	Heating	kWh/a	785	819	795	1367
Moisture Removal		l/h	1.0	1.3	1.8	2.1
Sound Pressure Level	Indoor (Cooling)	H/M/L/Q	38/33/29/20	40/34/29/20	40/35/30/20	43/36/30/20
	Indoor (Heating)	H/M/L/Q	41/35/31/22	42/36/31/22	42/38/33/22	44/39/33/24
	Outdoor (Cooling/Heating)	High	46/46	46/46	50/50	50/50
	Outdoor (Cooling/Heating)	High	54/56	55/57	55/58	57/59
Sound Power Level	Indoor (Cooling/Heating)	High	61/61	61/62	65/65	65/66
	Indoor/Outdoor (Cooling)	High	650/1,650	700/1,650	700/1,700	770/1,680
Airflow Rate	Indoor/Outdoor (Heating)	High	720/1,450	750/1,450	780/1,470	820/1,580
Net Dimensions H x W x D	Indoor	mm	270 x 834 x 222	270 x 834 x 222	270 x 834 x 222	270 x 834 x 222
	Outdoor	mm	541 x 663 x 290	541 x 663 x 290	541 x 663 x 290	542 x 799 x 290
Weight	Indoor	kg	10	10	10	10
	Outdoor	kg	22	22	24	31
Connection Pipe Diameter (Liquid/Gas)		mm	6.35/9.52	6.35/9.52	6.35/9.52	6.35/9.52
Drain Hose Diameter (I.D./O.D.)		mm	13.8/15.0 to 16.8	13.8/15.0 to 16.8	13.8/15.0 to 16.8	13.8/15.0 to 16.8
Max. Pipe Length (Pre-Charge)		m	20 (15)	20 (15)	20 (15)	20 (15)
Max. Height Difference			15	15	15	15
Operating Range	Cooling	°CDB	-10 to 46	-10 to 46	-10 to 46	-10 to 46
	Heating	°CDB	-15 to 24	-15 to 24	-15 to 24	-15 to 24
Refrigerant	Type (Global Warming Potential)		R32 (675)	R32 (675)	R32 (675)	R32 (675)
	Charge	kg (CO2eq-T)	0.6 (0.405)	0.6 (0.405)	0.7 (0.473)	0.85 (0.574)

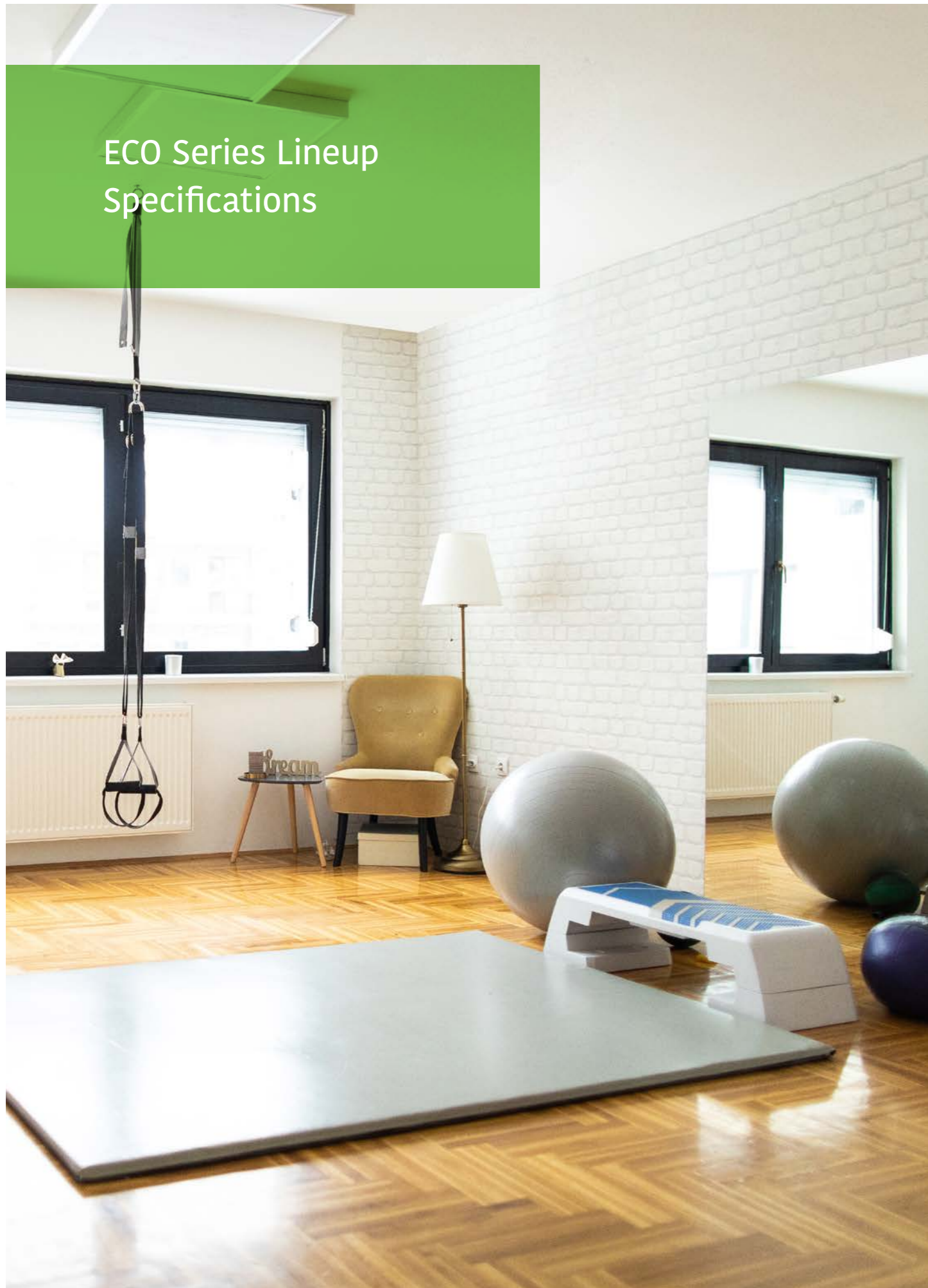

ECO Series Lineup Specifications

Compact Cassette



For more information and the latest updates, click here



Model name	Indoor unit		AUXG09KVLA	AUXG12KVLA	AUXG14KVLA	AUXG18KVLA	AUXG22KVLA	AUXG24KVLA
	Outdoor unit		AOEG09KATA	AOEG12KATA	AOEG14KATA	AOEG18KATA	AOEG22KATA	AOEG24KATA
Power Source			Single phase, ~230 V, 50 Hz					
Capacity	Cooling	Rated	2.5	3.5	4.3	5.2	6.0	6.8
		Min.-Max.	0.9-2.7	0.9-3.7	0.9-4.5	0.9-5.4	0.9-6.3	0.9-7.4
	Heating	Rated	3.2	4.1	5.0	6.0	7.0	7.5
Min.-Max.		0.9-3.9	0.9-4.4	0.9-5.3	0.9-6.3	0.9-7.4	0.9-8.6	
Input Power	Cooling/Heating		0.68/0.88	1.09/1.17	1.37/1.42	1.69/1.72	1.95/2.00	2.26/2.08
EER	Cooling		3.68	3.21	3.14	3.08	3.08	3.01
COP	Heating		3.64	3.50	3.52	3.49	3.50	3.61
Pdesign	Cooling/Heating (-10°C)		2.5/2.3	3.5/2.8	4.3/3.2	5.2/3.8	6.0/4.4	6.8/5.4
SEER	Cooling		6.2	6.1	6.1	6.1	6.1	5.9
SCOP	Heating		4.0	4.0	4.0	3.9	3.9	3.8
Energy Efficiency Class	Cooling		A++	A++	A++	A++	A++	A+
	Heating		A+	A+	A+	A	A	A
Max. Operating Current	Cooling/Heating		6.9/6.9	7.7/7.7	9.2/9.2	10.1/10.1	11.6/11.6	12.6/12.6
Annual Energy Consumption	Cooling		141	201	247	298	344	403
	Heating		804	979	1,120	1,362	1,578	1,988
Sound Pressure Level	Indoor (Cooling)	H/M/L/Q	33/31/29/27	37/34/30/27	38/34/30/27	38/34/30/26	44/42/36/30	49/44/36/30
	Indoor (Heating)	H/M/L/Q	34/32/29/27	37/34/31/29	43/38/34/30	43/38/34/30	45/43/40/33	49/45/40/33
Sound Power Level	Outdoor (Cooling/Heating)	High	47/48	49/50	50/51	51/52	52/53	54/55
	Indoor (Cooling/Heating)	High	46/47	49/49	50/55	50/55	56/57	59/61
Airflow Rate	Indoor/Outdoor (Cooling)	High	540/1,610	600/1,630	680/1,670	680/1,710	830/2,240	930/2,885
	Indoor/Outdoor (Heating)	High	540/1,550	600/1,410	800/1,580	800/1,840	860/2,240	930/2,350
Net Dimensions H x W x D	Indoor		245 x 570 x 570	245 x 570 x 570	245 x 570 x 570	245 x 570 x 570	245 x 570 x 570	245 x 570 x 570
	Outdoor		541 x 663 x 290	541 x 663 x 290	542 x 799 x 290	542 x 799 x 290	632 x 799 x 290	632 x 799 x 290
Weight	Indoor/Outdoor		15/23	15/25	15/32	15/33	16/36	16/38
Connection Pipe Diameter (Liquid/Gas)			6.35/9.52	6.35/9.52	6.35/9.52	6.35/12.70	6.35/12.70	6.35/12.70
Max. Pipe Length (Pre-Charge)			15 (15)	15 (15)	20 (15)	20 (15)	25 (15)	25 (20)
Operating Range	Cooling		-10 to 46	-10 to 46	-10 to 46	-10 to 46	-10 to 46	-10 to 46
	Heating		-15 to 24	-15 to 24	-15 to 24	-15 to 24	-15 to 24	-15 to 24
Refrigerant	Type (Global Warming Potential)		R32 (675)	R32 (675)	R32 (675)	R32 (675)	R32 (675)	R32 (675)
Cassette Grille	Model name		UTG-UFYF-W					
	Dimensions (H x W x D)		49 x 620 x 620	49 x 620 x 620	49 x 620 x 620	49 x 620 x 620	49 x 620 x 620	49 x 620 x 620
	Weight		2.3	2.3	2.3	2.3	2.3	2.3

Circular Cassette (Slim type)



For more information and the latest updates, click here



Model name	Indoor unit		AUXG18KRLB	AUXG22KRLB	AUXG24KRLB
	Outdoor unit		AOEG18KATA	AOEG22KATA	AOEG24KATA
Power Source			Single phase, ~230 V, 50 Hz		
Capacity	Cooling	Rated	5.2	6.0	6.8
		Min.-Max.	0.9-5.4	0.9-6.3	0.9-7.4
	Heating	Rated	6.0	7.0	7.5
Min.-Max.		0.9-6.3	0.9-7.4	0.9-8.6	
Input Power	Cooling/Heating		1.60/1.66	1.85/1.93	2.12/1.97
EER	Cooling		3.25	3.24	3.21
COP	Heating		3.61	3.63	3.81
Pdesign	Cooling/Heating (-10°C)		5.2/3.8	6.0/4.4	6.8/5.4
SEER	Cooling		6.2	6.2	6.1
SCOP	Heating		4.1	4.1	4.0
Energy Efficiency Class	Cooling		A++	A++	A++
	Heating		A+	A+	A+
Max. Operating Current	Cooling/Heating		10.1/10.1	11.6/11.6	12.6/12.6
Annual Energy Consumption	Cooling		293	338	390
	Heating		1,297	1,502	1,887
Sound Pressure Level	Indoor (Cooling)	H/M/L/Q	33/32/31/28	33/32/31/28	35/33/32/29
	Indoor (Heating)	H/M/L/Q	33/32/31/28	33/32/31/28	35/33/32/29
Sound Power Level	Outdoor (Cooling/Heating)	High	51/52	52/53	54/55
	Indoor (Cooling/Heating)	High	47/47	49/49	49/49
Airflow Rate	Indoor/Outdoor (Cooling)	High	1,050/1,710	1,050/2,240	1,150/2,885
	Indoor/Outdoor (Heating)	High	1,050/1,840	1,050/2,240	1,150/2,350
Net Dimensions H x W x D	Indoor		246 x 840 x 840	246 x 840 x 840	246 x 840 x 840
	Outdoor		542 x 799 x 290	632 x 799 x 290	632 x 799 x 290
Weight	Indoor/Outdoor		23/33	23/36	24/38
Connection Pipe Diameter (Liquid/Gas)			6.35/12.70	6.35/12.70	6.35/12.70
Max. Pipe Length (Pre-Charge)			20 (15)	25 (15)	25 (20)
Operating Range	Cooling		-10 to 46	-10 to 46	-10 to 46
	Heating		-15 to 24	-15 to 24	-15 to 24
Refrigerant	Type (Global Warming Potential)		R32 (675)	R32 (675)	R32 (675)
Cassette Grille	Model name		UTG-UKYA-W: White wired remote controller (touch panel) UTG-UKYC-W: White/UTG-UKYA-B*1: Black		
	Dimensions (H x W x D)		53 x 950 x 950	53 x 950 x 950	53 x 950 x 950
	Weight		6.0	6.0	6.0

*1: IR Receiver Kit and Occupancy Sensor Kit cannot be connected.

Circular Cassette (Large type)



For more information and the latest updates, click here



Model name	Indoor unit		AUXG30KRLB	AUXG36KRLB	AUXG45KRLB	AUXG54KRLB	AUXG36KRLB	AUXG45KRLB	AUXG54KRLB
	Outdoor unit		AOEG30KATA	AOEG36KATA	AOEG45KATA	AOEG54KATA	AOEG36KQTA	AOEG45KQTA	AOEG54KQTA
Power Source	Single phase, ~230 V, 50 Hz						3-phase, ~400 V, 50 Hz		
Capacity	Cooling	Rated	8.5	9.5	12.1	13.4	9.5	12.1	13.4
		Min.-Max.	2.8-9.6	2.8-10.6	4.0-12.6	4.5-13.8	2.8-10.6	4.0-12.6	4.5-13.8
Capacity	Heating	Rated	10.0	10.8	13.5	13.7	10.8	13.5	13.7
		Min.-Max.	2.7-10.8	2.7-12.5	4.2-15.0	4.7-16.0	2.7-12.5	4.2-15.0	4.7-16.0
Input Power	Cooling/Heating		2.56/2.64	3.06/2.58	4.32/3.77	4.87/4.86	3.06/2.58	4.32/3.77	4.87/4.86
EER	Cooling		3.32	3.10	2.80	2.75	3.10	2.80	2.75
EER	Heating		3.79	4.19	3.58	3.19	4.19	3.58	3.19
Pdesign	Cooling/Heating (-10°C)		8.5/8.0	9.5/8.7	12.1/9.2	13.4/9.5	9.5/8.7	12.1/9.2	13.4/9.5
SEER	Cooling		6.1	6.1	5.40	6.00	6.1	5.40	6.00
SCOP	Heating		4.0	4.0	3.80	3.85	4.0	3.80	3.85
Energy Efficiency Class	Cooling		A++	A++	-	-	A++	-	-
Energy Efficiency Class	Heating		A+	A+	-	-	A+	-	-
ηc			-	-	213.0	237.0	-	213.0	237.0
ηh			-	-	149.0	151.0	-	149.0	151.0
Max. Operating Current	Cooling/Heating		22.5/22.5	22.5/22.5	28.1/28.1	28.1/28.1	10.5/10.5	13.6/13.6	13.6/13.6
Annual Energy Consumption	Cooling		488	545	-	-	545	-	-
	Heating		2,794	3,044	-	-	3,044	-	-
Sound Pressure Level	Indoor (Cooling)	H/M/L/Q	40/38/36/33	44/41/38/34	46/42/39/35	47/43/40/36	44/41/38/34	46/42/39/35	47/43/40/36
	Indoor (Heating)	H/M/L/Q	40/38/36/33	44/41/38/34	46/42/39/35	47/43/40/36	44/41/38/34	46/42/39/35	47/43/40/36
Sound Power Level	Outdoor (Cooling/Heating)	High	53/55	55/55	58/59	58/61	55/55	60/60	61/61
	Indoor (Cooling/Heating)	High	54/54	58/58	60/60	61/61	58/58	-/-	-/-
Airflow Rate	Indoor/Outdoor (Cooling)	High	1,600/3,750	1,870/3,750	2,000/4,450	2,100/4,450	1,870/3,750	2,000/4,450	2,100/4,450
	Indoor/Outdoor (Heating)	High	1,600/3,750	1,870/3,750	2,000/4,450	2,100/4,780	1,870/3,750	2,000/4,450	2,100/4,780
Net Dimensions	Indoor		288 × 840 × 840	288 × 840 × 840	288 × 840 × 840	288 × 840 × 840	288 × 840 × 840	288 × 840 × 840	288 × 840 × 840
H x W x D	Outdoor		788 × 940 × 320	788 × 940 × 320	998 × 940 × 320	998 × 940 × 320	788 × 940 × 320	998 × 940 × 320	998 × 940 × 320
Weight	Indoor/Outdoor		26/52	29/52	29/61	29/63	29/52	29/62	29/63
Connection Pipe Diameter (Liquid/Gas)			9.52/15.88	9.52/15.88	9.52/15.88	9.52/15.88	9.52/15.88	9.52/15.88	9.52/15.88
Max. Pipe Length (Pre-Charge)			30 (30)	30 (30)	30 (30)	30 (30)	30 (30)	30 (30)	30 (30)
Operating Range	Cooling	°CDB	-10 to 46	-10 to 46	-10 to 46	-10 to 46	-10 to 46	-10 to 46	-10 to 46
	Heating	°CDB	-15 to 24	-15 to 24	-15 to 24	-15 to 24	-15 to 24	-15 to 24	-15 to 24
Refrigerant	Type (Global Warming Potential)		R32 (675)	R32 (675)	R32 (675)	R32 (675)	R32 (675)	R32 (675)	R32 (675)
Cassette Grille	Model name		UTG-UKYA-W: White wired remote controller (touch panel) UTG-UKYC-W: White/UTG-UKYA-B*1: Black						
	Dimensions (H × W × D)		53 × 950 × 950	53 × 950 × 950	53 × 950 × 950	53 × 950 × 950	53 × 950 × 950	53 × 950 × 950	53 × 950 × 950
	Weight		6.0	6.0	6.0	6.0	6.0	6.0	6.0

*1: IR Receiver Kit and Occupancy Sensor Kit cannot be connected.

Medium Static Pressure Duct (High-Efficiency & Comfort)



For more information and the latest updates, click here



Model name	Indoor unit		ARXH12KMTAP	ARXH14KMTAP	ARXH18KMTAP	ARXH22KMTAP	ARXH24KMTAP
	Outdoor unit		AOEG12KATA	AOEG14KATA	AOEG18KATA	AOEG22KATA	AOEG24KATA
Power Source	Single phase, ~230 V, 50 Hz						3-phase, ~400 V, 50 Hz
Capacity	Cooling	Rated	3.5	4.3	5.2	6.0	6.8
		Min.-Max.	0.9-3.7	0.9-4.5	0.9-5.4	0.9-6.3	0.9-7.4
Capacity	Heating	Rated	4.1	5.0	6.0	7.0	7.5
		Min.-Max.	0.9-4.4	0.9-5.3	0.9-6.3	0.9-7.4	0.9-8.6
Input Power	Cooling/Heating		1.060 / 1.170	1.340 / 1.420	1.730 / 1.820	1.85 / 1.97	2.06 / 1.97
EER	Cooling		3.30	3.21	3.00	3.24	3.30
EER	Heating		3.50	3.52	3.30	3.55	3.81
Pdesign	Cooling/Heating (-10°C)		3.5 / 2.8	4.3 / 3.2	5.2 / 3.8	6.0 / 4.4	6.8 / 5.4
SEER	Cooling		6.00	5.80	5.90	6.00	6.00
SCOP	Heating (Average)		3.90	3.90	3.90	3.90	3.90
Energy Efficiency Class	Cooling		A+	A+	A+	A+	A+
Energy Efficiency Class	Heating (Average)		A	A	A	A	A
Max. Operating Current	Cooling/Heating		7.7 / 7.7	9.2 / 9.2	10.1 / 10.1	11.6 / 11.6	12.6 / 12.6
Annual Energy Consumption	Cooling		212	267	316	358	405
	Heating		1,005	1,148	1,363	1,578	1,936
Sound Pressure Level	Indoor (Cooling)	H/M/L/Q	29 / 27 / 25 / 23	32 / 29 / 27 / 25	33 / 30 / 28 / 26	32 / 28 / 25 / 24	34 / 30 / 28 / 26
	Indoor (Heating)	H/M/L/Q	29 / 27 / 25 / 23	32 / 29 / 27 / 25	33 / 30 / 28 / 26	32 / 28 / 25 / 24	34 / 30 / 28 / 26
Sound Power Level	Outdoor (Cooling/Heating)	High	49 / 50	50 / 51	51 / 52	52 / 53	54 / 55
	Indoor (Cooling/Heating)	High	58 / 58	59 / 59	60 / 60	58 / 58	60 / 60
Airflow Rate	Indoor/Outdoor (Cooling)	High	650 / 1,630	800 / 1,670	840 / 1,710	1,150 / 2,240	1,230 / 2,885
	Indoor/Outdoor (Heating)	High	650 / 1,410	800 / 1,580	840 / 1,840	1,150 / 2,240	1,230 / 2,350
Static pressure range (Standard)			Pa	30 to 150 (40)	30 to 150 (40)	30 to 150 (40)	30 to 150 (50)
Net Dimensions	Indoor		240 × 700 × 700	240 × 700 × 700	240 × 700 × 700	240 × 1,000 × 700	240 × 1,000 × 700
H x W x D	Outdoor		541 × 663 × 290	542 × 799 × 290	542 × 799 × 290	632 × 799 × 290	632 × 799 × 290
Weight	Indoor/Outdoor		24/25	24/32	24/33	31/36	31/38
Connection Pipe Diameter (Liquid/Gas)			6.35 / 9.52	6.35 / 9.52	6.35 / 12.7	6.35 / 12.70	6.35 / 12.70
Max. Pipe Length (Pre-Charge)			15 (15)	20 (15)	20 (15)	25 (15)	25 (20)
Operating Range	Cooling	°CDB	-10 to 46	-10 to 46	-10 to 46	-10 to 46	-10 to 46
	Heating	°CDB	-15 to 24	-15 to 24	-15 to 24	-15 to 24	-15 to 24
Refrigerant	Type (Global Warming Potential)		R32 (675)	R32 (675)	R32 (675)	R32 (675)	R32 (675)

Slim Duct



For more information and the latest updates, click here



Model name	Indoor unit		ARXG09KLLAP	ARXG12KLLAP	ARXG14KLLAP	ARXG18KLLAP
	Outdoor unit		AOEG09KATA	AOEG12KATA	AOEG14KATA	AOEG18KATA
Power Source	Single phase, ~230 V, 50 Hz					
Capacity	Cooling	Rated	2.5	3.5	4.3	5.2
		Min.-Max.	0.9-2.7	0.9-3.7	0.9-4.5	0.9-5.4
Capacity	Heating	Rated	3.2	4.1	5.0	6.0
		Min.-Max.	0.9-3.9	0.9-4.4	0.9-5.3	0.9-6.3
Input Power	Cooling/Heating		0.69/0.88	1.09/1.17	1.37/1.42	1.66/1.71
EER	Cooling		3.62	3.21	3.14	3.13
EER	Heating		3.64	3.50	3.52	3.51
Pdesign	Cooling/Heating (-10°C)		2.5/2.3	3.5/2.8	4.3/3.2	5.2/3.8
SEER	Cooling		5.9	5.8	5.6	5.8
SCOP	Heating		3.8	3.8	3.8	3.8
Energy Efficiency Class	Cooling		A+	A+	A+	A+
Energy Efficiency Class	Heating		A	A	A	A
Max. Operating Current	Cooling/Heating		6.9/6.9	7.7/7.7	9.2/9.2	10.1/10.1
Annual Energy Consumption	Cooling		148	211	269	313
	Heating		847	1,031	1,177	1,398
Sound Pressure Level	Indoor (Cooling)	H/M/L/Q	28/27/26/25	29/28/26/25	32/30/28/26	32/30/29/27
	Indoor (Heating)	H/M/L/Q	28/26/25/24	29/28/26/24	32/30/28/25	32/30/29/27
Sound Power Level	Outdoor (Cooling/Heating)	High	47/48	49/50	50/51	51/52
	Indoor (Cooling/Heating)	High	57/57	58/58	60/60	58/58
Airflow Rate	Indoor/Outdoor (Cooling)	High	600/1,610	650/1,630	800/1,670	940/1,710
	Indoor/Outdoor (Heating)	High	600/1,550	650/1,410	800/1,580	940/1,840
Static pressure range (Standard)			Pa	0 to 90 (25)	0 to 90 (25)	0 to 90 (25)
Net Dimensions	Indoor		198 × 700 × 620	198 × 700 × 620	198 × 700 × 620	198 × 900 × 620
H x W x D	Outdoor		541 × 663 × 290	541 × 663 × 290	542 × 799 × 290	542 × 799 × 290
Weight	Indoor/Outdoor		17/23	17/25	17/32	20/33
Connection Pipe Diameter (Liquid/Gas)			6.35/9.52	6.35/9.52	6.35/9.52	6.35/12.70
Max. Pipe Length (Pre-Charge)			15 (15)	15 (15)	20 (15)	20 (15)
Operating Range	Cooling	°CDB	-10 to 46	-10 to 46	-10 to 46	-10 to 46
	Heating	°CDB	-15 to 24	-15 to 24	-15 to 24	-15 to 24
Refrigerant	Type (Global Warming Potential)		R32 (675)	R32 (675)	R32 (675)	R32 (675)

Medium Static Pressure Duct (High-Efficiency & Comfort)



For more information and the latest updates, click here



Model name	Indoor unit		ARXH30KMTAP	ARXH36KMTAP	ARXH45KMTAP	ARXH36KMTAP	ARXH45KMTAP
	Outdoor unit		AOEG30KATA	AOEG36KATA	AOEG45KATA	AOEG36KQTA	AOEG45KQTA
Power Source	Single phase, ~230 V, 50 Hz				3-phase, ~400 V, 50 Hz		
Capacity	Cooling	Rated	8.5	9.5	12.1	9.5	12.1
		Min.-Max.	2.8-9.6	2.8-10.6	4.0-12.6	2.8-10.6	4.0-12.6
Capacity	Heating	Rated	10.0	10.8	13.5	10.8	13.5
		Min.-Max.	2.7-10.8	2.7-12.5	4.2-15.0	2.7-12.5	4.2-15.0
Input Power	Cooling/Heating		2.69 / 2.63	3.13 / 2.88	4.84 / 4.18	3.13 / 2.88	4.84 / 4.18
EER	Cooling		3.16	3.04	2.50	3.04	2.50
EER	Heating		3.80	3.75	3.23	3.75	3.23
Pdesign	Cooling/Heating (-10°C)		8.5 / 8.0	9.5 / 8.7	12.1 / 9.2	9.5 / 8.7	12.1 / 9.2
SEER	Cooling		5.80	5.60	4.90	5.60	4.90
SCOP	Heating (Average)		3.90	3.90	3.80	3.90	3.80
Energy Efficiency Class	Cooling		A+	A+	-	A+	-
Energy Efficiency Class	Heating (Average)		A	A	-	A	-
ηc			-	-	193.0	-	193.0
ηh			-	-	149.0	-	149.0
Max. Operating Current	Cooling/Heating		22.5 / 22.5	22.5 / 22.5	28.1 / 28.1	10.5 / 10.5	13.6 / 13.6
Annual Energy Consumption	Cooling		520	601	-	601	-
	Heating		2,867	3,118	-	3,118	-
Sound Pressure Level	Indoor (Cooling)	H/M/L/Q	38 / 34 / 31 / 28	38 / 34 / 31 / 28	40 / 36 / 32 / 29	38 / 34 / 31 / 28	40 / 36 / 32 / 2

Medium Static Pressure Duct (Standard)



For more information and the latest updates, click here



Model name	Indoor unit		ARXG22KMLB	ARXG24KMLA	ARXG30KMLA	ARXG36KMLA	ARXG45KMLA	ARXG36KMLA	ARXG45KMLA
	Outdoor unit		AOEG22KATA	AOEG24KATA	AOEG30KATA	AOEG36KATA	AOEG45KATA	AOEG36KQTA	AOEG45KQTA
Power Source	Single phase, ~230 V, 50 Hz							3-phase, ~400 V, 50 Hz	
Capacity	Cooling	Rated	6.0	6.8	8.5	9.5	12.1	9.5	12.1
		Min.-Max.	0.9-6.3	0.9-7.4	2.8-9.6	2.8-10.6	4.0-12.6	2.8-10.6	4.0-12.6
	Heating	Rated	7.0	7.5	10.0	10.8	13.5	10.8	13.5
		Min.-Max.	0.9-7.4	0.9-8.6	2.7-10.8	2.7-12.5	4.2-15.0	2.7-12.5	4.2-15.0
Input Power	Cooling/Heating		1.92/2.00	2.19/2.00	2.78/2.77	3.13/3.03	4.84/4.18	3.13/3.03	4.84/4.18
EER	Cooling		3.13	3.11	3.06	3.04	2.50	3.04	2.50
COP	Heating		3.50	3.75	3.61	3.56	3.23	3.56	3.23
Pdesign	Cooling/Heating (-10°C)		6.0/4.4	6.8/5.4	8.5/8.0	9.5/8.7	12.1/9.2	9.5/8.7	12.1/9.2
SEER	Cooling		5.8	5.9	5.8	5.6	4.85	5.6	4.85
SCOP	Heating		3.8	3.9	3.9	3.9	3.55	3.9	3.55
Energy Efficiency Class	Cooling		A+	A+	A+	A+	-	A+	-
	Heating		A	A	A	A	-	A	-
ηc			-	-	-	-	191.0	-	191.0
ηh			-	-	-	-	139.0	-	139.0
Max. Operating Current	Cooling/Heating		11.6/11.6	12.6/12.6	22.5/22.5	22.5/22.5	28.1/28.1	10.5/10.5	13.6/13.6
Annual Energy Consumption	Cooling		362	403	513	594	-	594	-
	Heating		1,620	1,935	2,871	3,122	-	3,122	-
Sound Pressure Level	Indoor (Cooling)	H/M/L/Q	31/29/27/25	31/29/27/25	39/35/30/26	39/35/30/26	42/38/32/28	39/35/30/26	42/38/32/28
		H/M/L/Q	31/29/27/25	31/29/27/25	42/35/30/26	42/35/30/26	42/38/32/28	42/35/30/26	42/38/32/28
	Outdoor (Cooling/Heating)	High	52/53	54/55	53/55	55/55	58/59	55/55	58/59
		High	60/62	60/62	65/69	65/70	68/70	65/70	68/70
Sound Power Level	Indoor (Cooling/Heating)	High	64/65	66/67	68/69	70/70	72/73	70/70	72/73
	Outdoor (Cooling/Heating)	High	1,100/2,240	1,100/2,240	1,900/3,750	1,900/3,750	2,100/4,450	1,900/3,750	2,100/4,450
Airflow Rate	Indoor/Outdoor (Cooling)	High	1,100/2,240	1,100/2,350	2,100/3,750	2,100/3,750	2,100/4,450	2,100/3,750	2,100/4,450
	Indoor/Outdoor (Heating)	High	1,100/2,240	1,100/2,350	2,100/3,750	2,100/3,750	2,100/4,450	2,100/3,750	2,100/4,450
Static pressure range (Standard)			Pa	30 - 150 (35)	30 - 150 (35)	30 - 150 (47)	30 - 150 (47)	30 - 150 (60)	30 - 150 (60)
Net Dimensions	Indoor		mm	270 × 1,135 × 700	270 × 1,135 × 700	270 × 1,135 × 700	270 × 1,135 × 700	270 × 1,135 × 700	270 × 1,135 × 700
H x W x D	Outdoor		mm	632 × 799 × 290	632 × 799 × 290	788 × 940 × 320	788 × 940 × 320	998 × 940 × 320	998 × 940 × 320
Weight	Indoor/Outdoor		kg	35/36	35/38	38/52	38/52	39/61	38/53
Connection Pipe Diameter (Liquid/Gas)			mm	6.35/12.70	6.35/12.70	9.52/15.88	9.52/15.88	9.52/15.88	9.52/15.88
Max. Pipe Length (Pre-Charge)			m	25 (15)	25 (20)	30 (30)	30 (30)	30 (30)	30 (30)
Operating Range	Cooling		°CDB	-10 to 46	-10 to 46	-10 to 46	-10 to 46	-10 to 46	-10 to 46
	Heating		°CDB	-15 to 24	-15 to 24	-15 to 24	-15 to 24	-15 to 24	-15 to 24
Refrigerant	Type (Global Warming Potential)			R32 (675)	R32 (675)	R32 (675)	R32 (675)	R32 (675)	R32 (675)

Ceiling









For more information and the latest updates, click here



Model name	Indoor unit		ABEG18KRTA	ABEG22KRTA	ABEG24KRTA	ABEG30KRTA	ABEG36KRTA	ABEG45KRTA	ABEG36KRTA	ABEG45KRTA
	Outdoor unit		AOEG18KATA	AOEG22KATA	AOEG24KATA	AOEG30KATA	AOEG36KATA	AOEG45KATA	AOEG36KQTA	AOEG45KQTA
Power Source	Single phase, ~230 V, 50 Hz							3-phase, ~400 V, 50 Hz		
Capacity	Cooling	Rated	5.2	6.0	6.8	8.5	9.5	12.1	9.5	12.1
		Min.-Max.	0.9-5.4	0.9-6.3	0.9-7.4	2.8-9.6	2.8-10.6	4.0-12.6	2.8-10.6	4.0-12.6
	Heating	Rated	6.0	7.0	7.5	10.0	10.8	13.5	10.8	13.5
		Min.-Max.	0.9-6.3	0.9-7.4	0.9-8.6	2.7-10.8	2.7-12.5	4.2-15.0	2.7-12.5	4.2-15.0
Input Power	Cooling/Heating		1.66/1.71	1.95/2.09	2.19/2.00	2.78/2.86	3.13/3.03	4.84/4.18	3.13/3.03	4.84/4.18
EER	Cooling		3.13	3.08	3.11	3.06	3.04	2.50	3.04	2.50
COP	Heating		3.51	3.35	3.75	3.5	3.56	3.23	3.56	3.23
Pdesign	Cooling/Heating (-10°C)		5.2/3.8	6.0/4.4	6.8/5.4	8.5/8.0	9.5/8.7	12.1/9.2	9.5/8.7	12.1/9.2
SEER	Cooling		5.8	5.6	6.0	5.8	5.6	5.20	5.6	5.20
SCOP	Heating		3.8	3.8	3.9	3.9	3.9	3.80	3.9	3.80
Energy Efficiency Class	Cooling		A+	A+	A+	A+	A+	-	A+	-
	Heating		A	A	A	A	A	-	A	-
ηc			-	-	-	-	-	205.0	-	205.0
ηh			-	-	-	-	-	149.0	-	149.0
Max. Operating Current	Cooling/Heating		10.1/10.1	11.6/11.6	12.6/12.6	22.5/22.5	22.5/22.5	28.1/28.1	10.5/10.5	13.6/13.6
Annual Energy Consumption	Cooling		538	375	679	512	594	-	594	-
	Heating		1,398	1,618	1,935	2,871	3,117	-	3,117	-
Sound Pressure Level	Indoor (Cooling)	H/M/L/Q	38/36/33/31	42/37/34/31	41/36/32/29	45/40/35/32	44/40/37/32	45/41/39/34	44/40/37/32	45/41/39/34
		H/M/L/Q	38/36/33/31	42/37/34/31	41/36/32/29	45/40/35/32	44/40/37/32	45/41/39/34	44/40/37/32	45/41/39/34
	Outdoor (Cooling/Heating)	High	51/52	52/53	54/55	53/55	55/55	58/59	55/55	58/59
		High	53/53	57/57	56/56	60/60	59/59	60/60	59/59	60/60
Sound Power Level	Indoor (Cooling/Heating)	High	63/64	64/65	66/67	68/69	70/70	72/73	70/70	72/73
	Outdoor (Cooling/Heating)	High	840/1,710	900/2,240	1,230/2,885	1,400/3,750	1,850/3,750	1,900/4,450	1,850/3,750	1,900/4,450
Airflow Rate	Indoor/Outdoor (Cooling)	High	840/1,840	900/2,240	1,230/2,350	1,400/3,750	1,800/3,750	1,850/4,450	1,800/3,750	1,850/4,450
	Indoor/Outdoor (Heating)	High	840/1,840	900/2,240	1,230/2,350	1,400/3,750	1,800/3,750	1,850/4,450	1,800/3,750	1,850/4,450
Net Dimensions	Indoor		mm	235 × 1,080 × 705	235 × 1,080 × 705	235 × 1,390 × 705	235 × 1,390 × 705	235 × 1,700 × 705	235 × 1,700 × 705	235 × 1,700 × 705
H x W x D	Outdoor		mm	542 × 799 × 290	632 × 799 × 290	632 × 799 × 290	788 × 940 × 320	788 × 940 × 320	988 × 940 × 320	988 × 940 × 320
Weight	Indoor/Outdoor		kg	24/33	24/36	31/38	31/52	38/52	38/61	38/53
Connection Pipe Diameter (Liquid/Gas)			mm	6.35/12.7	6.35/12.7	6.35/12.7	9.52/15.88	9.52/15.88	9.52/15.88	9.52/15.88
Max. Pipe Length (Pre-Charge)			m	20 (15)	25 (15)	25 (20)	30 (30)	30 (30)	30 (30)	30 (30)
Operating Range	Cooling		°CDB	-10 to 46	-10 to 46	-10 to 46	-10 to 46	-10 to 46	-10 to 46	-10 to 46
	Heating		°CDB	-15 to 24	-15 to 24	-15 to 24	-15 to 24	-15 to 24	-15 to 24	-15 to 24
Refrigerant	Type (Global Warming Potential)			R32 (675)	R32 (675)	R32 (675)	R32 (675)	R32 (675)	R32 (675)	R32 (675)

Feature Summary

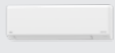
○ : Optional function

































































Type	Wall-Mounted			Wall-Mounted			
Series	Designer Range	Standard Range		ECO Range	ECO Range		Standard Range
Model name	 ASEH07/09/12/14KJCAL, ASEH07/09/12/14KJCALB, ASYH07/09/12/14KJCA, ASYH07/09/12/14KJCA-B	 ASEH07/09/12/14KMCG, ASEH07/09/12/14KMCG-B, ASYG07/09/12/14KMCF, ASYG07/09/12/14KMCE	 ASEH18/24KMTGL	 ASEH07/09/12KNCA	 ASEH07/09/12KLTBL	 ASEH18/24KLCBL	 ASEH30/36KMTB
Energy-Saving Features	Save Occupancy sensor	●					●
	Occupancy sensor control						
	Economy operation	●	●	●	●	●	●
	Setting temperature range limitation	●	○	○	○	○	○
	Set temperature auto return	○	○	○			○
Features for Comfort	Powerful operation	●	●	●	●	●	●
	10°C Heat	●	●	●	●		●
	Outdoor unit low noise operation	●	●	●			●
	Auto changeover	●	●	●	●	●	●
	UP/DOWN swing louver	●	●	●	●	●	●
	Double swing automatic	●		●			●
	Automatic fan speed	●	●	●	●	●	●
	Auto restart	●	●	●	●	●	●
	Connectable fresh air duct						
	Fresh air intake						
	Connectable distributing duct						
	Individual airflow direction control						
	Auto-off timer	○	○	○			○
	Sleep timer	●	●	●	●	●	●
Program timer	●	●	●	●	●	●	
Weekly timer	●	● ^{*3} (KMCF) ○ ^{*3} (KMCG, KMCE)	●	○ ^{*3}	●	● ^{*3}	●
Weekly & Temperature setback timer	○	○	○			○	
Filter sign	●	●	●	●	●	●	
External error output	○	○	○			○	
External ON/OFF input	○	○	○			○	
Wireless LAN control	● (KJCAL, KJCALB) ○ (KJCA, KJCA-B)	● (KMCF, KMCG, KMCG-B) ○ (KMCE)	●	●	●	●	
Multi system control*1						○	
Special cooling						● ^{*2}	
Individual auto	●						
Clean Features	Ion deodorization filter	●	●	●			●
	Apple-catechin filter	●	●	●			●
	Long-life filter						
	Washable panel	●	●	●	●	●	●
	Silver Ion Filter	○	○	○	○	○	○
Heat Clean	●						
Installation / Support	Automatic airflow adjustment						
	Drain pump						
	Blue fin	●			●	●	●
	Refrigerant cycle monitor	○	○ (KMCG, KMCG-B)	○			○

*1 For details of Multi System Control function, refer to C-010. *2 Wired remote controller (UTY-RNRYZ6) is required to use Special Cooling function.

*3: It is only available on the AIRSTAGE Mobile application. It can not be used via wireless remote controller.

Feature Summary

●: Compatible with all types of remote controls
○: Functions available only on specific remote controls (see Comparison Table of Controllers for details (C-010))

Type	Cassette		Duct			Duct						Floor	Ceiling
	Compact 4-way Flow Range Fits grid ceiling	Circular Flow Range Comfort for Large Rooms	Low Static Pressure Range Slim Duct	Medium Static Pressure Range Slim & Compact Standard		Compact Size	High Static Pressure Duct Standard			Big Duct			
Series													
Model name	AUXG 09/12/14/18/22/24 KVL A	AUXG 18/22/24/30/36/45/54 KRL B	ARXG 09/12/14/18 KLL A P	ARXH 12/14/18/22/24/ 30/36/45/54 KMT A P	ARXG22KMLB ARXG 24/30/36/45 KML A	ARXG 12/14/18/22/ 24/30/36/45/54 KHT A P	ARXG45/54KHTB	ARXH60KHTA	ARYG60LHTA	ARXH72/90KHTA	ARYG72/90LHTA	AGEG09/12/14KVCA	ABEG 18/22/24/30/ 36/45/54 KRT A
													
Energy-Saving Features	 Save Occupancy sensor												
	 Occupancy sensor control		○										
	 Economy operation	●	●	●	●	●	●	●	●	●	●	●	●
	 Setting temperature range limitation	○	○	○	○	○	○	○	○	○	○	○	○
	 Set temperature auto return	○	○	○	○	○	○	○	○	○	○	○	○
Features for Comfort	 Powerful operation												●
	 10°C Heat	○	○	○	○	○	○	○	○	○	○	○	○
	 Outdoor unit low noise operation		○*1 (30-54)		○*1 (30-54)	○*1 (30-54)	○*1 (30-54)	○*1	○*1	○*1	○*1	○*1	○*1
	 Auto changeover	●	●	●	●	●	●	●	●	●	●	●	●
	 UP/DOWN swing louver	●	●	○									●
	 Double swing automatic												
	 Automatic fan speed	●	●	●	●	●	●	●	●	●	●	●	●
	 Auto restart	●	●	●	●	●	●	●	●	●	●	●	●
	 Connectable fresh air duct	●	●		●	●	●						●
	 Fresh air intake	○	○	○	○	○	○	○	○	○	○	○	○
	 Connectable distributing duct		●			●							
	 Individual airflow direction control		○										
Convenience Features*2	 Auto-off timer	○	○	○	○	○	○	○	○	○	○	○	○
	 Sleep timer	○	○	○	○	○	○	○	○	○	○	○	○
	 Program timer	○	○	○	○	○	○	○	○	○	○	○	○
	 Weekly timer	○	○	○	○	○	○	○	○	○	○	○	○
	 Weekly & Temperature setback timer	○	○	○	○	○	○	○	○	○	○	○	○
	 Filter sign	●	●	●	●	●	●	●	●	●	●	●	●
	 External error output*4*5	○	○	○	○	○	○	○	○	○	○	○	○
	 External ON/OFF input	●	●	●	●	●	●	●	●	●	●	●	●
	 Wireless LAN control	○	○	○	○	○	○	○	○	○	○	○	○
	 Multi system control								○		○		
Clean Features	 Special cooling*6								○		○		
	 Individual auto												
	 Ion deodorization filter											●	
	 Apple-catechin filter											●	
	 Long-life filter				○	○	○	○	○	○	○	○	○
Installation / Support	 Washable panel												
	 Silver Ion Filter	○	○	○	○	○	○	○	○	○	○	○	○
	 Heat Clean												
	 Automatic airflow adjustment				●	●	●	●	●	●	●	●	●
	 Drain pump	●	●	●	●	○	○	○	○	○	○	○	○
 Blue fin		● (30/36/45/54)		● (30/36/45/54)	● (30/36/45)	● (30/36/45/54)	●	●	●	●	●	● (30/36/45/54)	
 Refrigerant cycle monitor*7				○									

*1 External input function for the outdoor unit.
*2 For details of Convenience Features function, refer to C-010.
*3 This feature is only available when using the wireless remote controller.
*4 The Fresh air intake and External error output cannot be used simultaneously. Simultaneous use requires the external I/O board (UTY-XCSX).

*5 An optional external input/output kit is required.
*6 Wired remote controller (UTY-RNRYZ6) is required to use Special Cooling function.
*7 This function is only supported by split units, using the H-Serial communication protocol. Example: ASYH30KMTBL