

Residential, Commercial & Light Commercial VENTILATION

VENTILATION Lineup

- Vn-002 Energy Recovery Ventilator
- Vn-004 DX kit for Air Handling Applications
 - for VRF Outdoor unit
- Vn-006 DX kit for Air Handling Applications
 - for Single Split Outdoor Units



Lineup

Airflow rate (m ³ /h)	250		350		500		800		1000							
Energy Recovery Ventilator																
	UTZ-BD025C		UTZ-BD035C		UTZ-BD050C		UTZ-BD080C		UTZ-BD100C							
Connectable capacity class (kW)	5.0	6.3	8.0	10.0	12.5	14.0	20.0	25.0	40.0	50.0						
DX kit for Air Handling Applications for VRF Outdoor unit																
	EUV unit UTP-VX30B		Control unit UTY-VDGXZ3		EUV unit UTP-VX60B		Control unit UTY-VDGXZ3		EUV unit UTP-VX90B		Control unit UTY-VDGXZ3		EUV unit UTP-VX90Bx2		Control unit UTY-VDGXZ3	
Connectable capacity class (kW)	2.5 - 22.0															
DX kit for Air Handling Applications for Single Split Outdoor Units																
	UTY-XDZX															

Energy Recovery Ventilator

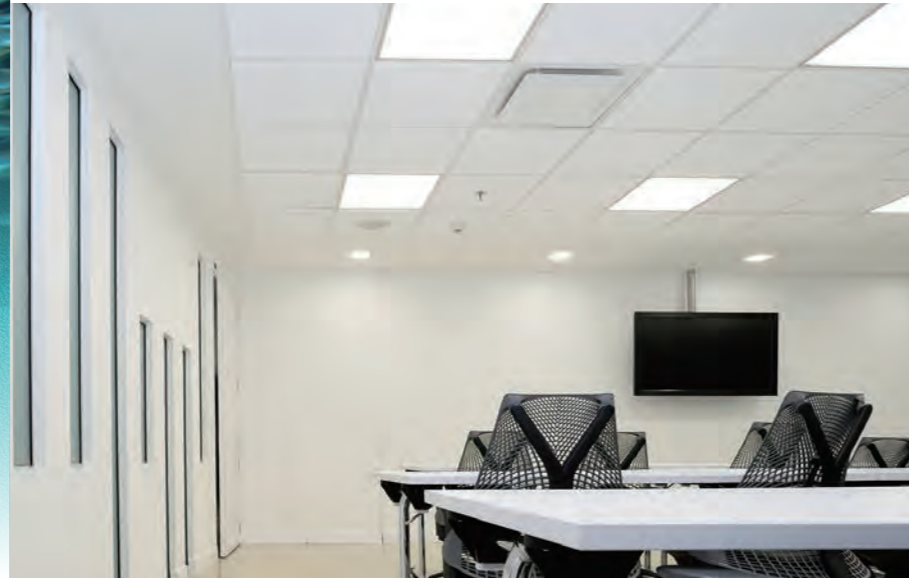

The energy recovery ventilator unit provides energy efficiency for comfort and improved savings.

Heat Exchange Ventilation and Normal Ventilation

Heat exchange ventilation

When a room is cooled or heated, the exhausted cooling or heating energy is recovered by heat exchange ventilation.

Normal ventilation

Used when the indoor space does not require cooling or heating, i.e., when there is little temperature difference between the indoor and outdoor environments.

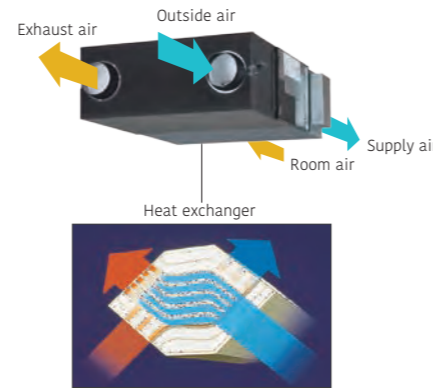

A high-efficiency counter-flow heat-exchanging element is used in the setup.

Energy Efficiency and Ecology

The use of a counter-flow heat-exchanging element, designed to recover up to 77% of heat from the outgoing air, significantly reduces energy consumption. The air conditioning load is reduced by approximately 20%, which results in substantial savings in energy cost.

Comparison of Heat-Exchanging Elements

Air flows in a straight line through a cross-flow element. In contrast, air flows for a longer time (a longer distance) through a counter-flow element to achieve more consistent heat-exchanging performance.

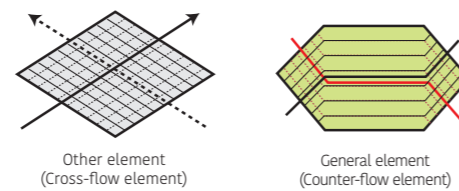

Quiet Operation

Significantly lower noise levels are achieved by reducing pressure loss.

25.5dB
(UTZ-BD035C)

Extended Range of External Static Pressure

The use of a powerful fan motor improves the external static pressure. This allows it to be installed in a variety of buildings.

Slim Design for Easier Installation

The use of a counter-flow heat-exchanging element made it possible to design a quieter, slimmer unit.



Reverse-Mountable Direct Air Supply and Exhaust System

Simplifies the duct design, due to its straight ducts for air supply and exhaust. Since each unit can be mounted facing opposite directions, only one inspection hole is needed for two units. This makes duct work easier and more flexible.

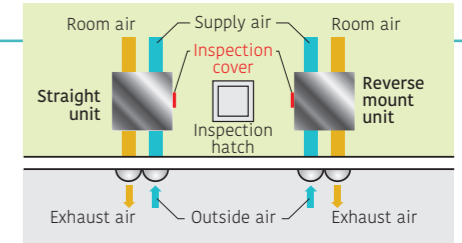

Simple Remote Operation

Easy operation with connected liquid crystal switch

- Power On/Off
- Air volume High/Low
- Heat exchange ventilation and normal ventilation
- On/Off Timer
- Clean filter display



Model: UTZ-BD025C/UTZ-BD035C/UTZ-BD050C/UTZ-BD080C/UTZ-BD100C



Specifications

Rated flow rate	250 m ³ /h		350 m ³ /h		500 m ³ /h		800 m ³ /h		1000 m ³ /h	
Model name	UTZ-BD025C		UTZ-BD035C		UTZ-BD050C		UTZ-BD080C		UTZ-BD100C	
Power source	Single phase, ~220 to 240 V, 50 Hz									
Heat Exchange Ventilation	Input power	(Extra high)/High/Low	W	128/123/96	190/185/168	289/225/185	418/378/295	464/432/311		
	Airflow rate	(Extra high)/High/Low	m ³ /h	250/25/190	350/350/240	500/500/440	800/800/630	1,000/1,000/700		
	External static pressure	(Extra high)/High/Low	Pa	105/95/45	140/60/45	120/60/35	140/110/55	105/80/75		
	Temperature exchange efficiency	(Extra high)/High/Low	%	75/75/77	75/75/78	75/75/76	75/75/76	75/75/79		
	Energy exchange efficiency cooling	(Extra high)/High/Low	%	63/63/65	66/66/71	62/62/64	65/65/68	65/65/70		
	Energy exchange efficiency heat pump	(Extra high)/High/Low	%	70/70/72	69/69/73	67/67/69	71/71/74	71/71/76		
Normal Ventilation	Sound pressure level	(Extra high)/High/Low	dB*	31.5/30.5/26.5	33.0/31.0/25.5	37.5/35.5/32.5	37.5/37.0/34.5	38.5/37.5/34.5		
	Input power	(Extra high)/High/Low	W	128/123/96	190/185/168	289/225/185	418/378/295	464/432/311		
	Airflow rate	(Extra high)/High/Low	m ³ /h	250/25/190	350/350/240	500/500/440	800/800/630	1,000/1,000/700		
	External static pressure	(Extra high)/High/Low	Pa	105/95/45	140/60/45	120/60/35	140/110/55	105/80/75		
Sound pressure level	(Extra high)/High/Low	dB*	31.5/30.5/26.5	33.0/31.0/25.5	38.5/38.0/32.5	37.5/37.0/34.5	40.5/39.5/36.5			
Dimensions	W × D × H		mm	882 × 599 × 270	1,050 × 804 × 317	1,090 × 904 × 317	1,322 × 884 × 388	1,322 × 1,134 × 388		
Weight			kg	29	49	57	71	83		
Outlet duct diameter			mm	150	150	200	250	250		
Operating range			°C	-10 to 40	-10 to 40	-10 to 40	-10 to 40	-10 to 40		
Maximum humidity			%	85	85	85	85	85		

* Noise level measured 1.5 m below the center of the unit

Dimensions

(Unit: mm)

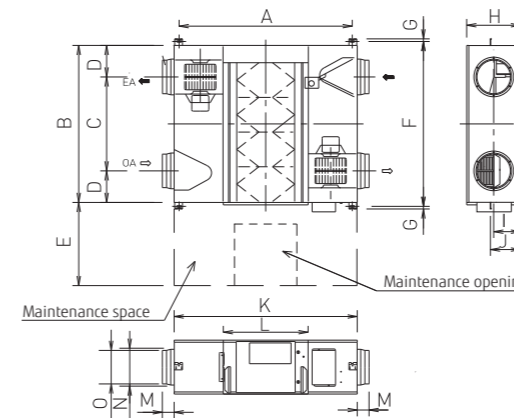

	UTZ-BD025C	UTZ-BD035C	UTZ-BD050C	UTZ-BD080C	UTZ-BD100C
A	810	978	1,018	1,250	1,250
B	599	804	904	884	1,134
C	315	580	640	428	678
D	142	112	132	228	228
E	600	600	600	600	600
F	655	860	960	940	1,190
G	19	19	19	19	19
H	270	317	317	388	388
I	135	159	159	194	194
J	159	182	182	218	218
K	882	1,050	1,090	1,322	1,322
L	414	470	470	612	612
M	95	70	70	85	85
N	Ø164	Ø164	Ø210	Ø258	Ø258
O	Ø144	Ø144	Ø194	Ø242	Ø242

DX kit for Air Handling Applications for VRF Outdoor unit

With these kits, air handling units (AHUs) and fan coil units (FCUs) from other manufacturers can be incorporated into General VRF systems, or one AHU can be connected to one General VRF dedicated outdoor unit to control outdoor ventilation and room temperatures.

Multiple Temperature Sensors Optimally Control an Air Handling Unit and a Fan Coil Unit

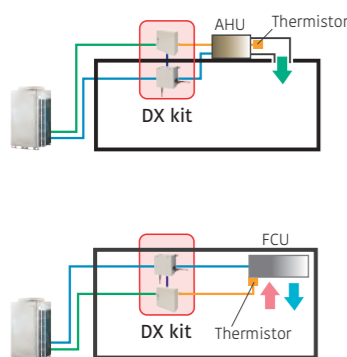

When connected to an Air handling unit, the temperature of supply air is controlled by a discharge air sensor.

When connected to a fan coil unit, the room temperature is controlled by the Suction air sensor.

Application as part of a VRF system

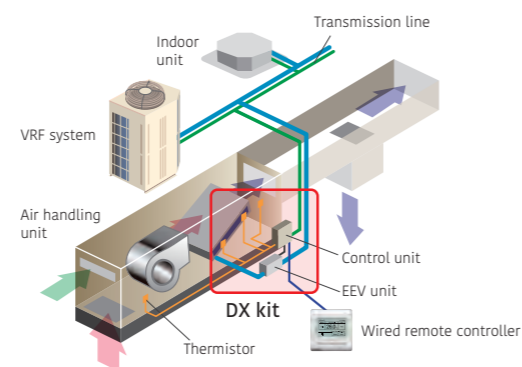

Supports a Wide Range of Capacity Classes

- Two EEV units can be connected in parallel to large-capacity units of up to 20 HP (50 kW). (UTP-LX180A separation tube required)
- Connectable capacity range: 5 kW to 50 kW

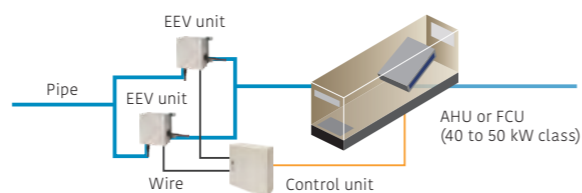

A Variety of Control Options that Meet Application Requirements

Central control enabled by our VRF controllers or central management controllers

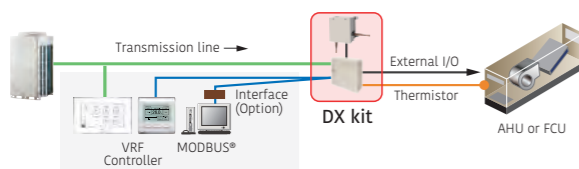

Central control from external controllers

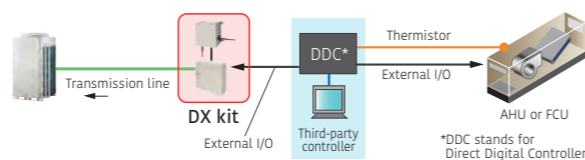

*DDC stands for Direct Digital Controller

Summary of Functions

Inputs

- On/Off
- Setting temperature
- Capacity demand
- Heating/Cooling operation modes
- Fault information

Outputs

- On/Off indication
- Fan On/Off indication
- Thermostat On/Off indication
- Defrost indication
- Fault indication
- Low airflow alarm

MODBUS® Control

Can be controlled via a MODBUS®-enabled BMS using an optional interface.

Installation Requirements

- Connectable VRF series: All VRF series
- Capacity range of connectable DX kit systems with outdoor units: 50 to 100% of capacity
- Capacity range of connectable DX kit systems with indoor units: 30% or less of capacity
- Max. wire length from a control unit: 10 m
- Max. pipe length between EEV unit and indoor unit: 5 m
- A control unit (IP54 class) and an EEV unit can be installed outdoors.

Connectable capacity

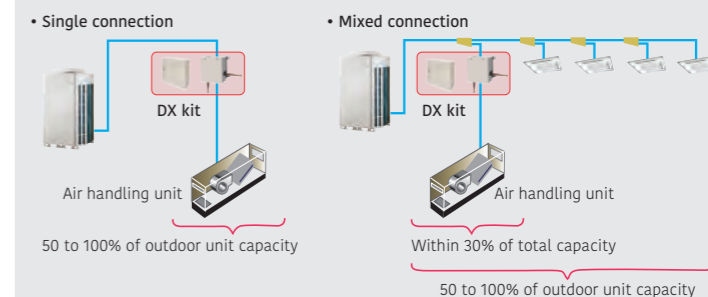

Pipe and wire length

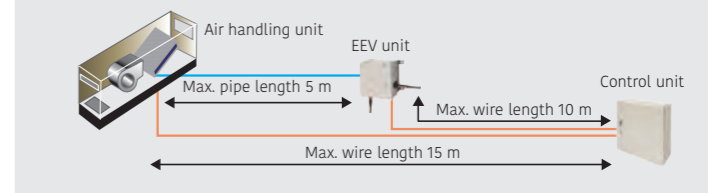

Optional separation tube to connect two EEV units: UTP-LX180A



Control unit: UTY-VDGXZ3 EEV unit: UTP-VX30B/UTP-VX60B/UTP-VX90B

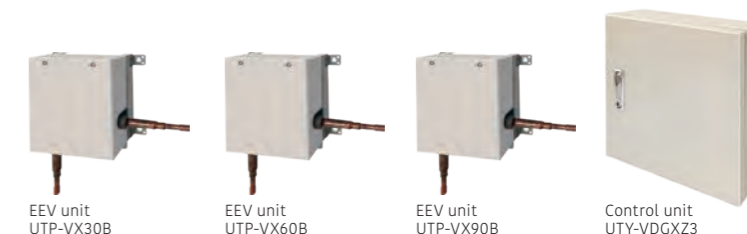

Specifications

Connectable capacity class		5.0 kW	6.3 kW	8.0 kW	10.0 kW	12.5 kW	14.0 kW	20.0 kW	25.0 kW	40.0 kW	50.0 kW
Capacity	Cooling	5.6	6.3	8.0	10.0	12.5	14.0	22.4	25.0	40.0	50.4
	Heating	6.3	7.1	9.0	11.2	14.0	16.0	25.0	28.0	45.0	56.5

Control unit		UTY-VDGXZ3			
Power source		230/1/50			
Dimensions (H × W × D)		400 × 400 × 120			

EEV unit		UTP-VX30B	UTP-VX60B	UTP-VX90B	UTP-VX90B × 2
Connection pipe diameter (Liquid)		Ø6.35	Ø9.52	Ø9.52	Ø12.70
Dimensions (H × W × D)		160 × 220 × 90			

Note: Specifications are based on the following conditions.
Cooling: Indoor temperature of 27°CDB/19°CWB, and outdoor temperature of 35°CDB/24°CWB.
Heating: Indoor temperature of 20°CDB/(15°CWB), and outdoor temperature of 7°CDB/6°CWB.
Pipe length: 7.5 m Voltage: 230 [V].

DX kit for Air Handling Applications for Single Split Outdoor Units



With this kit, other manufacturers' Air handling units (AHUs) and fan coil units (FCUs) can be incorporated into General Split outdoor units.

Flexible Connectivity

This kit allows connections to third-party equipment. This control unit can also be used in conjunction with General single-split outdoor units, providing a perfect solution when a stand-alone Air handling unit is needed.

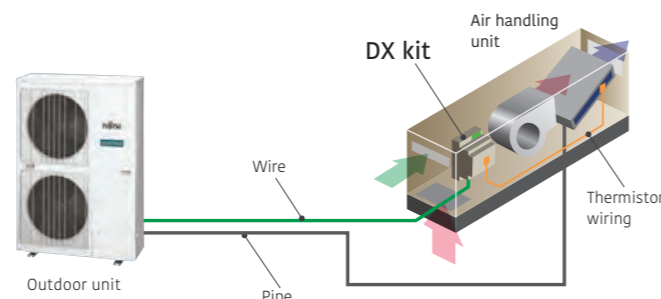

Supports a Wide Range of Capacity Classes

Capable of connecting large capacities in the range of 2.5 kW to 22.0 kW (Nominal)



Mobile Devices Allow for Operation from Anywhere

Can be operated and managed remotely using your smartphone or tablet.

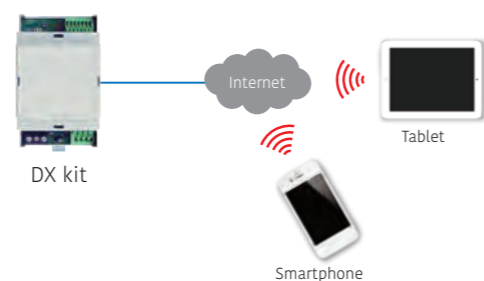

Summary of Functions

Inputs

- On/Off
- Heating/Cooling operation modes
- Capacity demand (analogue 0 to 10 V)
- Heat exchanger temperature

Outputs

- Status of Compressor, Defrost, and Errors (Potential free relays)
- Status indicator with LED

Wireless LAN Control

Wireless LAN control through cloud connectivity enables secure remote monitoring and control from anywhere.

Easy Installation

- Compact DIN rail mountable enclosure for easy installation
- No expansion devise required
- No separate external power supply required

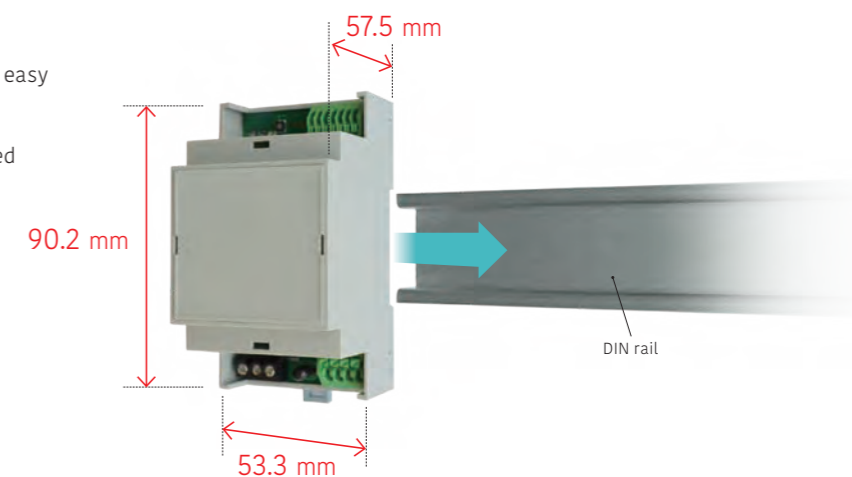

Model: UTY-XDZX



Specifications

R410A models

Capacity (Nominal)	kW		12	14	18	24	30	36	45	54	60	72	90
	Cooling			3.5	4.3	5.2	6.8	8.5	9.4	12.1	13.3	15.0	19.0
Heating			4.1	5.0	6.0	7.8	10.0	10.8	13.3	15.8	18.0	22.4	27.0

R32 models

Capacity (Nominal)	kW		09	12	14	18	22	24	30	36	45	54
	Cooling			2.5	3.5	4.3	5.2	6.0	6.8	8.5	9.4	12.1
Heating			3.2	4.1	5.0	6.0	7.0	7.5	10.0	10.8	13.3	15.8

Model name		UTY-XDZX	
Power source	V/Ø/Hz	230/1/50	
Dimensions (H × W × D)	mm	90.2 × 53.3 × 57.5	
Weight	g	110	

Note: Specifications are based on the following conditions.
Cooling: Indoor temperature of 27°CDB/19°CWB, and outdoor temperature of 35°CDB/24°CWB.
Heating: Indoor temperature of 20°CDB/(15°CWB), and outdoor temperature of 7°CDB/6°CWB.
Pipe length: 5.0 m Voltage: 230 [V].